

# STOLPORT MANUAL

SECOND EDITION — 1991



*Approved by the Secretary General  
and published under his authority*

**INTERNATIONAL CIVIL AVIATION ORGANIZATION**



# Stolport Manual

(Doc 9150-AN/899)

Second Edition — 1991





# Foreword

This manual provides guidance for the planning and establishment of stolports, unique airports designed to serve aeroplanes that have exceptional short-field performance capabilities. While “stolport” and “STOL aircraft” have not been precisely defined by ICAO, it is recognized that the capability of certain aeroplanes to operate safely in areas constrained by limited space, restricted terrain or both, offers economic and social advantages provided there are dedicated airports available.

A stolport is an airport whose physical characteristics, visual and non-visual aids and total infrastructure are created to support safe and effective public air transport in and out of densely populated urban areas as well as to and from rural areas with difficult terrain.

As no Standards or Recommended Practices for stolports exist in any of the ICAO Annexes, this manual covers all the aircraft operating aspects of stolports except non-visual navigation aids. The airport terminal building and groundside operations are not addressed.

The material in this manual is based on adaptations of conventional airport practices and on the experience of States that have operated stolports or complete STOL systems. It should, however, be noted that stolport

specifications included herein are not applicable to altiports which are constructed in mountainous regions, though some of the STOL aircraft in use today are designed to operate from altiports. An altiport may be defined as a small airport in a mountainous area with a steep gradient runway, used for landing up the slope and for take-off down the slope, thereby making use of only one approach/departure area. On the other hand, the longitudinal slope of a STOL runway is flatter than even that prescribed for a runway designed for the operation of conventional aircraft and generally has approach/departure areas at both ends of the runway.

Contemporary “short-field” aeroplanes fall into a rather narrow range with respect to size and performance. The guidance in this manual caters to that fact. The future of civil STOL aircraft development is uncertain, but should progress in this area lead to larger aeroplanes, a revision of some of the material in this manual will be required.

It is intended that the manual be kept up to date. Future editions will be improved on the basis of experience gained and of comments and suggestions received from users of this manual. Therefore, readers are invited to give their views, comments, and suggestions on this edition. These should be directed to the Secretary General of ICAO.



# Table of Contents

	<i>Page</i>		<i>Page</i>
Chapter 1. General .....	1	3.5.3 Strength of aprons .....	8
1.1 Introduction .....	1	3.5.4 Slopes of aprons .....	8
1.2 Applicability .....	1		
1.3 Site selection .....	1	Chapter 4. Obstacle Limitation Surfaces .....	10
Chapter 2. Stolport data .....	3	4.1 General .....	10
2.1 General .....	3	4.2 Take-off and approach surfaces .....	10
Chapter 3. Physical characteristics .....	4	4.2.1 General .....	10
3.1 General .....	4	4.2.2 Take-off and approach surface boundaries .....	10
3.2 Runways .....	4	4.2.3 Take-off and approach surfaces/slopes .....	12
3.2.1 Number and orientation of runways .....	4	4.2.4 Dimensions of take-off and approach surfaces .....	12
3.2.2 Runway length .....	4	4.3 Transitional surfaces .....	12
3.2.3 Stopways and clearways .....	4	4.3.1 General .....	12
3.2.4 Runway width .....	6	4.3.2 Characteristics of a transitional surface .....	12
3.2.5 Longitudinal and transverse slopes .....	6	4.4 Inner horizontal surfaces .....	13
3.2.6 Strength of runways .....	6	4.4.1 General .....	13
3.2.7 Surface of runways .....	6	4.4.2 Characteristics of an inner horizontal surface .....	13
3.3 Runway strips .....	6	Chapter 5. Visual Aids for Navigation .....	14
3.3.1 General .....	6	5.1 General .....	14
3.3.2 Runway strip width and length .....	7	5.2 Markings, general .....	14
3.3.3 Graded areas .....	7	5.3 Runway markings .....	14
3.3.4 Longitudinal and transverse slopes of runway strips .....	7	5.3.1 Stolport designation marking .....	14
3.3.5 Objects on runway strips .....	7	5.3.2 Threshold marking .....	14
3.4 Taxiways .....	7	5.3.3 Runway designation marking .....	14
3.4.1 General .....	7	5.3.4 Runway centre line marking .....	17
3.5 Aprons .....	7	5.3.5 Runway side stripe marking .....	17
3.5.1 General .....	7	5.3.6 Touchdown zone marking .....	17
3.5.2 Size of aprons .....	8	5.3.7 Runway exit marking .....	17

	<i>Page</i>		<i>Page</i>		
5.4	Taxiway marking .....	17	Chapter 6. Visual Aids for Denoting Objects ....	31	
5.5	Wind direction indicator .....	17	6.1	Objects to be marked and lighted .....	31
5.6	Stolport lighting .....	17	6.2	Marking and lighting of objects .....	31
5.6.1	General .....	17	Chapter 7. Visual Aids for Denoting Restricted		
5.6.2	Dangerous and confusing lights .	21	Use Areas .....	32	
5.6.3	Light fixtures and supporting		7.1	Closed runway and taxiway marking ....	32
	structures .....	21	7.2	Unserviceable-area marking .....	32
5.6.4	Light intensity and control .....	21	7.3	Movement area unserviceability lighting ..	32
5.6.5	Stolport beacon .....	21	7.4	Pre-threshold area .....	32
5.6.6	Approach lighting system .....	21	7.5	Non load-bearing surface marking .....	32
5.6.7	Visual approach slope indicator		Chapter 8. Equipment and Installations .....	34	
	system .....	22	8.1	Secondary power supply .....	34
5.6.8	Runway lead-in lights .....	24	8.2	Monitoring .....	34
5.6.9	Runway threshold identification		8.3	Fencing .....	34
	lights .....	24	8.4	Siting and construction of equipment and	
5.6.10	Runway edge lights .....	24		installations on operational areas .....	34
5.6.11	Runway threshold lights .....	27	8.5	Stolport vehicle operation .....	35
5.6.12	Displaced runway threshold		Chapter 9. Emergency and Other Services .....	36	
	lights .....	27	9.1	Stolport emergency planning .....	36
5.6.13	Runway end lights .....	27	9.2	Rescue and fire fighting .....	36
5.6.14	Combined runway threshold and		9.3	Disabled aircraft removal .....	36
	runway end lights .....	27	9.4	Maintenance .....	36
5.6.15	Stopway lights .....	27	9.5	Bird hazard control .....	37
5.6.16	Runway touchdown zone lights .	27	9.6	Apron management service .....	37
5.6.17	Taxiway and apron lighting ....	29	Appendix A. Definitions .....	39	
5.6.18	Aircraft control of lighting .....	29	Appendix B. Aeroplane types .....	41	
5.7	Signs .....	29	Bibliography .....	44	
5.7.1	General .....	29			
5.7.2	Mandatory instruction signs ....	29			
5.7.3	Information signs .....	30			
5.8	Markers .....	30			
5.8.1	General .....	30			
5.8.2	Unpaved runway edge markers ..	30			
5.8.3	Edge markers for snow covered				
	runways .....	30			
5.8.4	Unpaved taxiway edge markers .	30			



# Chapter 1

## General

### 1.1 INTRODUCTION

1.1.1 This manual provides general guidance on stolport site selection, physical characteristics, obstacle limitation surfaces and visual aids that should be provided at stolports, as well as certain facilities and technical services normally provided at an aerodrome.

1.1.2 A stolport is a viable alternative in cases where runway length, location, and departure and approach path obstacles would prohibit the establishment of a conventional airport. As with a conventional airport, the physical characteristics of a stolport will depend upon the size and performance capabilities of the stolport design aeroplane. The type of operation envisaged at the stolport will depend upon community needs, available resources, and location. Depending on the operational requirements of the stolport, it can be designed for use in all meteorological conditions, or only in visual meteorological conditions; by day and night, or by day only.

1.1.3 For the purposes of this manual, the stolport design aeroplane is assumed to be an aeroplane that has a reference field length of 800 m or less. In size, the stolport design aeroplane is assumed to have a wingspan of up to 26 m and a main landing gear measurement of up to 9 m. Moreover, in light of the evident lack of commitment of larger civil STOL aircraft to production, it is assumed that aeroplanes thus described are probably the viable STOL option. Accordingly, the guidance in this manual rests on estimates of what constitutes a practical set of criteria composed on the basis of available data. It does not consider additional characteristics that might be thought suitable for more demanding aircraft.

1.1.4 In order to ensure regular service to a stolport, operations under the instrument flight rules may be required. Given the runway length and steep approach angles, operating minima for the stolport are not likely to be less than Category I aerodrome operating minima. When all the relevant factors are considered, the operating minima for the stolport may need to be considerably higher than the lower limit of Category I approach landing

operations. However, in order to provide operational flexibility, when it is intended that a stolport be provided with a precision approach, that stolport should be designed on the basis of a precision approach runway Category I.

1.1.5 The guidance in this manual is not intended to limit or regulate the operation of aircraft.

### 1.2 APPLICABILITY

1.2.1 The guidance material provided in this manual is meant for the use of stolport planners and the appropriate airport certifying authorities in examining the feasibility of stolport operations at existing aerodromes or other sites and in the planning, design and approval of stolports. Interpretation of the material requires the exercise of discretion and the making of decisions, particularly by the airport authorities.

1.2.2 Although the specifications of Annex 14, Volume I, *Aerodrome Design and Operations* do not apply to stolports, much of the guidance material in this manual conforms to the International Standards and Recommended Practices set forth in that Annex. The user will find it necessary, therefore, to refer to the Annex in conjunction with this manual. Also useful for guidance are the *Aerodrome Design Manual* (Doc 9157), the *Airport Planning Manual* (Doc 9184) and the *Airport Services Manual* (Doc 9137).

### 1.3 SITE SELECTION

1.3.1 Before a commitment of resources is made to establish a stolport or system of stolports in an urban area, there should be recognized social, environmental, economic, and operational advantages over existing transportation systems. These advantages hinge on the potential of greatly reducing trip time by providing service from one urban centre to another. In addition, advantages

accrue from the decreased congestion in major terminal areas, from the smaller amount of land required and from the low environmental impact of the take-off and approach capabilities of STOL aircraft.

1.3.2 To maximize the advantages offered by a STOL system, a stolport should be located as near as possible to the market it is intended to serve. Ideally this location should be close to passenger destinations and provide an air service that is integrated with convenient surface transportation.

1.3.3 While the utility of a stolport in serving a community is largely determined by its location in densely populated areas, and its consequent convenience of location to the businesses and residents served, stolports are also useful in serving outlying areas where terrain precludes conventional air traffic.

1.3.4 The short runway of a stolport, the requirement for less airspace in the terminal area than needed by conventional air transport and the practicality of steep obstacle limitation surfaces allow greater flexibility in locating the site.

1.3.5 The ideal location for a stolport in many cases is land whose economic, recreational or aesthetic value outweighs the advantages accruing to a STOL system. In addition, the attitudes of nearby residents may result in strong community opposition to air operations making an otherwise suitable location politically unfeasible. In this connexion, noise sensitivity is a main cause of resistance so that stolport site selection may depend, in part, on the relative quietness of the stolport design aeroplane. In any event, site selection often requires a compromise involving the various elements of convenience, requirement for space, and economic utility. On the other hand, in many situations the location of a stolport need not encroach on sensitive areas. For example, suitable urban sites that offer convenience without disrupting community affairs have been operated at a disused metropolitan airport, a riverside

parking lot, a landfill site and in an abandoned dockyard. Beside these examples, land allocated to surface transportation corridors may be found to be compatible with nondisruptive use.

1.3.6 It is also practical to locate a stolport at an existing airport, particularly where the STOL service is a feeder-line service. Although a stolport runway could be incorporated into existing runways, it is preferable that a separate runway be devoted to STOL operations. In the latter case, three dimensional navigation equipment and suitable approach aids would permit stolport users discrete access to busy airports without seriously interfering with conventional traffic.

1.3.7 Once a stolport site is provisionally selected, planning authorities will have to consider the details of construction and application of stolport specifications. This consideration might include a series of demonstration flights. The flights would serve several purposes. The adequacy of noise avoidance plans would be tested; the community would be reassured about the safety and compatibility of STOL operations; the effects of air turbulence caused by nearby structures could be tested; and route structures and ATS separation standards could be established.

1.3.8 At the same time, the site would be examined with respect to the provision of convenient ground transportation, without which some advantage is lost. Another important consideration governing site selection is the nature and composition of the soil and subsoil upon which prepared surfaces will be supported and, in particular, the adequacy of drainage. Detailed guidance on airport site evaluation and selection is given in the *Airport Planning Manual*, Part 1.

1.3.9 Lastly, having established a stolport location, planners will turn to the design using the descriptions provided in this manual to define the physical characteristics, obstacle limitation surfaces and visual aids. This guidance is contained in the following chapters.

---

# Chapter 2

## Stolport Data

### 2.1 GENERAL

2.1.1 Annex 14, Volume I, Chapter 2 sets forth details of aerodrome data to be determined about aerodromes and reported to the appropriate aeronautical information service. Where applicable, these requirements should be met for a stolport.

2.1.2 Where a stolport is established as part of a conventional airport, the stolport data should be

determined and reported as part of the conventional airport's aerodrome data.

2.1.3 Where the use of a stolport is restricted to a particular aeroplane type, the appropriate aeronautical information service should be informed.

2.1.4 Specifications on the manner in which stolport data should be reported are prescribed in Annexes 4 and 15.

---

# Chapter 3

## Physical Characteristics

### 3.1 GENERAL

3.1.1 The planning of a stolport comprises the development of suitable physical characteristics to provide the necessary operating elements for service by the stolport design aeroplane or similar aeroplanes. In addition, capacity or the forecast rate of utilization should be considered by the planner. The maximum rate of use is dependent on such factors as demand, weather and air traffic control capabilities as much as on stolport features. Although the characteristics described in this chapter are meant only to provide safe and effective field lengths and clearances, it is likely, in light of such external factors, that a stolport whose physical characteristics conform to this chapter could handle any forecast frequency of service.

3.1.2 Where appropriate, the physical characteristics described in this chapter have been adapted from the specifications set forth in Annex 14, Volume 1.

### 3.2 RUNWAYS

#### 3.2.1. Number and orientation of runways

3.2.1.1 Based on the degree of usability required, the type of operation of the stolport needs to be determined prior to making a decision regarding the number and orientation of runways. Attention should be paid in particular to whether the stolport is to be used in all meteorological conditions or only in visual meteorological conditions, and whether it is intended for use by day and night, or by day only.

3.2.1.2. In light of space and resource constraints, it is likely that the configuration for most stolports would be a single runway usable from either end and an associated taxiway (see Figure 3-1).

3.2.1.3 A scarcity of urban stolport sites may lessen the opportunity for an ideal runway orientation in the

direction of the prevailing wind. Nevertheless, stolport design should aim for maximum usability and the orientation of the runway should ensure that the usability factor as governed by the wind distribution is not less than 95 per cent for the stolport design aeroplane. Thus, in determining the allowable crosswind component to establish a usability factor, the crosswind limitation of the design aeroplane must be taken into account. Guidance on factors to be taken into account in the study of wind distribution is given in Annex 14, Volume I, Attachment A, Section 1.

3.2.1.4 The decision on runway orientation should also take into account areas over which traffic will operate on approach, missed approach and departure so that obstructions in these areas or other factors will not unduly restrict operations.

#### 3.2.2 Runway length

3.2.2.1 The length of a stolport runway should be based on take-off and landing data obtained from the aeroplane flight manual of the stolport design aeroplane and considered together with the following factors:

- a) whether the approaches are open or restricted;
- b) longitudinal slope of the proposed runway;
- c) elevation of the site;
- d) temperature and humidity of the site; and
- e) nature of the runway surface.

3.2.2.2 The length of a runway does not necessarily have to provide for operations by the design aeroplane at its maximum mass. Rather, the aeroplane mass selected should be the mass required to carry out its allocated task and different take-off and landing masses may be determined for each site served by the design aeroplane.

#### 3.2.3 Stopways and clearways

Where a stopway or clearway is provided, an actual runway length less than that suggested by 3.2.2.1 may be

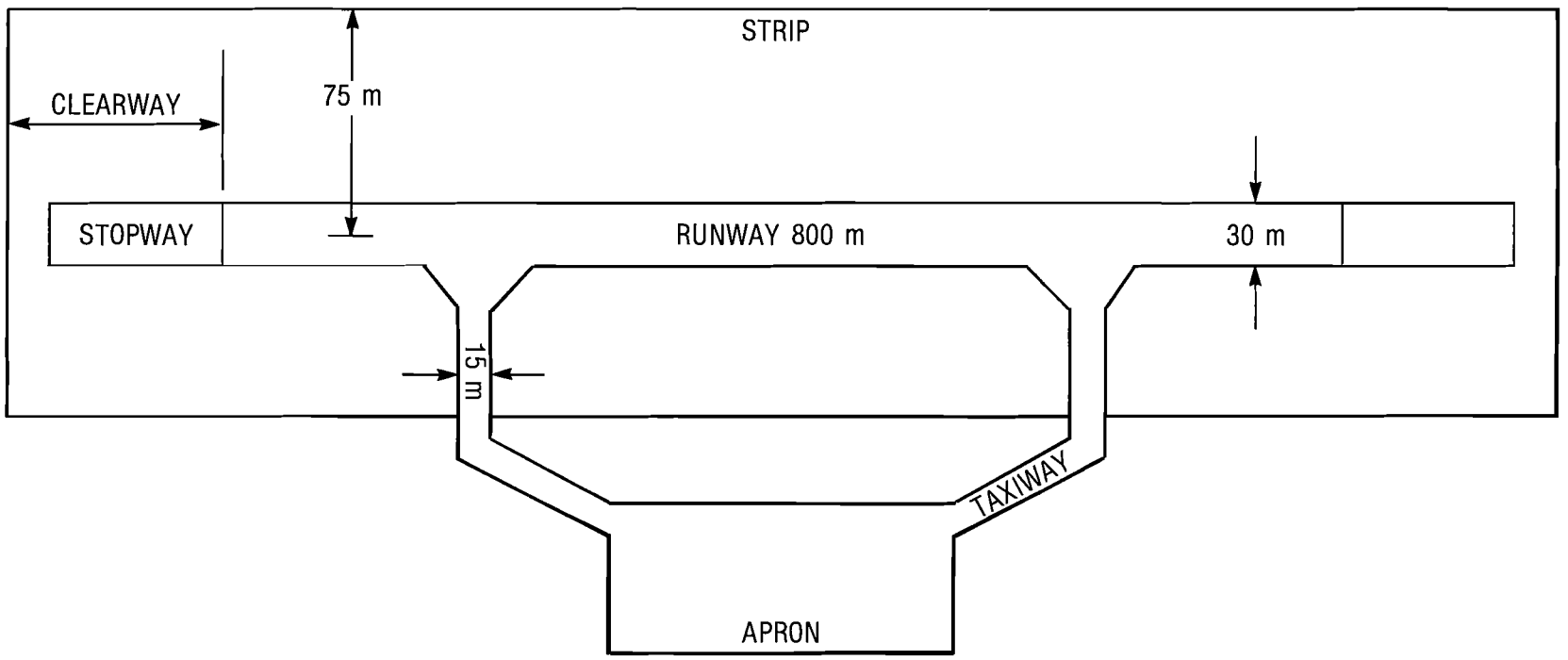

Figure 3-1. Typical stopport configuration

considered satisfactory. In such a case any combination of runway, stopway and clearway should meet the take-off and landing requirements of the stolport design aeroplane, taking into consideration the same factors as in 3.2.2.1. The guidance on the use of stopways and clearways given in Annex 14, Volume I, Attachment A, Section 2, is applicable to stolports.

### 3.2.4 Runway width

A runway width of 23 m has been considered generally suitable for aeroplanes like the stolport design aeroplane described in Chapter 1, for use in visual meteorological conditions. However, the width of a precision approach runway for such an aeroplane should be not less than 30 m.

### 3.2.5 Longitudinal and transverse slopes

3.2.5.1 Any excessive longitudinal slope on a runway will adversely affect both the landing and take-off roll of an aeroplane. For this reason wherever possible, the longitudinal slope of a stolport runway should be held to 1.0 per cent or less, not to exceed 2.0 per cent. The longitudinal slope of a runway can be obtained by dividing the difference between the highest elevation and the lowest elevation along the centre line by the runway length.

3.2.5.2 In cases where the longitudinal slope of a stolport runway exceeds 2.0 per cent, it may be necessary to advise the operators that operations are restricted to landing uphill and taking off downhill.

3.2.5.3 Longitudinal slopes of runways should conform to relevant Annex 14 specifications for runway code number 1.

3.2.5.4 To promote rapid drainage a stolport runway surface should either be cambered or sloped from high to low in the prevailing direction of wind associated with rain. A transverse slope should not exceed 2 per cent. For a cambered surface the slope on either side of the centre line should be symmetrical.

3.2.5.5 Transverse slopes should be substantially the same throughout the length of the runway except at the intersection with a taxiway where an even transition should be provided while maintaining adequate drainage.

3.2.5.6 Guidance on transverse slopes is given in the *Aerodrome Design Manual*, Part 3.

### 3.2.6 Strength of runways

3.2.6.1 A runway should have a bearing strength capable of supporting continual traffic of the stolport design aeroplane along the length of the declared take-off run or the declared landing distance, and throughout its full width.

3.2.6.2 A normal landing may impose little or no impact load on the landing surface. However, the load factors arising from an emergency or a badly controlled landing should be considered.

### 3.2.7 Surface of runways

3.2.7.1 The surface of a stolport runway should be constructed without irregularities that would affect aeroplane performance during take-off or landing. Surface unevenness that would cause vibration or other control difficulties of an aeroplane should be avoided. Guidance on runway surfaces is given in the *Aerodrome Design Manual*, Part 3.

3.2.7.2 The texture of the surface of a stolport runway requires special attention in view of the short-field landing requirements. A rough texture surface that is conducive to braking should be used. Where hydroplaning is anticipated to be prevalent, considerations should be given to grooving the runway surface. A grooved surface has been shown to be effective in providing braking action on wet runways. Guidance on methods used to measure surface texture is given in the *Airport Services Manual*, Part 2, while guidance on grooving runways is contained in the *Aerodrome Design Manual*, Part 3.

## 3.3 RUNWAY STRIPS

### 3.3.1 General

3.3.1.1 Each runway should be included in a runway strip. The purpose of a runway strip is to provide for the following operational considerations:

- a) a graded area for aeroplanes accidentally running off the runway;
- b) a cleared area for aeroplanes drifting from the runway after take-off;
- c) a cleared area for aeroplanes carrying out a missed approach initiated from a very low altitude;

- d) an area for the installation of essential visual and non-visual aids; and
- e) an area for drainage and run-off from the runway.

### 3.3.2 Runway strip width and length

3.3.2.1 A stolport runway strip width of at least 45 m on either side of the centre line is adequate for day-time operations in visual meteorological conditions. However, for operations at night or in instrument meteorological conditions, a width of 75 m on either side of the centre line is recommended.

3.3.2.2 A stolport runway strip length of 60 m beyond the end of each runway or stopway is recommended in order to provide for the considerations outlined in 3.3.1.1.

### 3.3.3 Graded areas

To provide for a) in 3.3.1.1, the portion of a runway strip outside the runway and within a distance of 40 m from the centre line of the strip should be graded. The surface of that portion of the runway strip that abuts the runway or stopway edge should be flush with the surface of the runway or stopway. To protect a landing aeroplane, the runway strip should be prepared against blast erosion to at least 30 m before a runway threshold. Drainage ditches, where required, should be located at the end of the graded area. To further reduce potential damage to an aeroplane that runs beyond the graded portion of the runway strip, the drainage ditch should be contoured.

### 3.3.4 Longitudinal and transverse slopes of runway strips

The longitudinal and transverse slopes on runway strips should conform to those specified in Annex 14, Volume I, for a strip associated with a runway with code number 1.

### 3.3.5 Objects on runway strips

For safety considerations, no object, unless essential as an aid to air navigation, should be installed on a runway strip. Air navigation equipment that must be located on a runway strip should be marked, be of minimum mass and height, and frangibly designed so as to constitute the minimum hazard to aircraft. Frangibility requirements are set out in Annex 14, Volume I, Chapters 3, 5 and 8.

## 3.4 TAXIWAYS

### 3.4.1 General

3.4.1.1 As mentioned in 3.2.1.2, the likely configuration of a stolport is a single runway served by a single taxiway. A runway should have sufficient entrance and exit taxiways to expedite movement of aeroplanes to and from the runway. Guidance on layout of taxiways is given in the *Aerodrome Design Manual*, Part 2. Where the end of a runway is not served by a taxiway, it may be necessary to provide additional pavement at the end of the runway for aeroplanes to turn.

3.4.1.2 A taxiway should be designed so that when the cockpit of the design aeroplane is over the taxiway centre line markings, the clearance distance between the outer main wheel of the aeroplane and the edge of the taxiway is not less than 3 m.

3.4.1.3 As previously mentioned, many of the guidelines in this manual conform to the specifications in Annex 14, Volume I. Insofar as specifications for aerodrome taxiways have been established based on the wing span and outer main gear wheel span of the aerodrome design aeroplane, the same specifications are applicable to stolport taxiways. When designing taxiways at a stolport, the specifications should conform to the Standards and Recommended Practices described in Annex 14, Volume I, Chapter 3.

3.4.1.4 It will not normally be necessary to allocate stolport space to holding bays but, where warranted by traffic volume, holding bays should be provided. If they are provided, they should conform to the specifications in Annex 14, Volume I, Chapter 3, Section 3.10.

## 3.5 APRONS

### 3.5.1 General

It will be necessary to provide an apron to permit the loading and unloading of passengers and cargo as well as aircraft servicing without interfering with stolport traffic. The distance from the edge of an apron to the edge of a runway strip should be sufficient for an aeroplane parked on the apron not to penetrate the transitional surface.

### **3.5.2 Size of aprons**

3.5.2.1 The necessary stolport capacity to handle planned or predicted stolport traffic will be the main determinant in establishing an apron's size. A stolport apron's size should be sufficient to contain an adequate number of gates or parking spaces to cater to the stolport's traffic volume at its highest level.

3.5.2.2 As the number of gates or parking spaces required will depend, in part, on gate occupancy or turnaround time, aircraft operators intending to use the stolport should be consulted with respect to scheduling and other matters that affect the time an aeroplane needs to occupy the apron.

3.5.2.3 The size of an apron will also be governed by the size of the stolport design aeroplane and the parking method selected for use on the apron. While nose-in parking uses less space, economy and convenience will

probably dictate self-manoeuvring, angled nose-in or angled nose-out parking. Figure 3-2 depicts a typical stolport apron.

### **3.5.3 Strength of aprons**

An apron should have sufficient bearing strength to support the mass of the stolport design aeroplane, keeping in mind that parts of the apron will be subject to higher stresses owing to slow moving and stationary aeroplanes.

### **3.5.4 Slopes of aprons**

3.5.4.1 Slopes of an apron should be sufficient to prevent accumulation of water but should not exceed 1 per cent in any direction.

3.5.4.2 Because of the possibility of spilled fuel and the ensuing fire hazard, an apron should not slope down towards a terminal building.



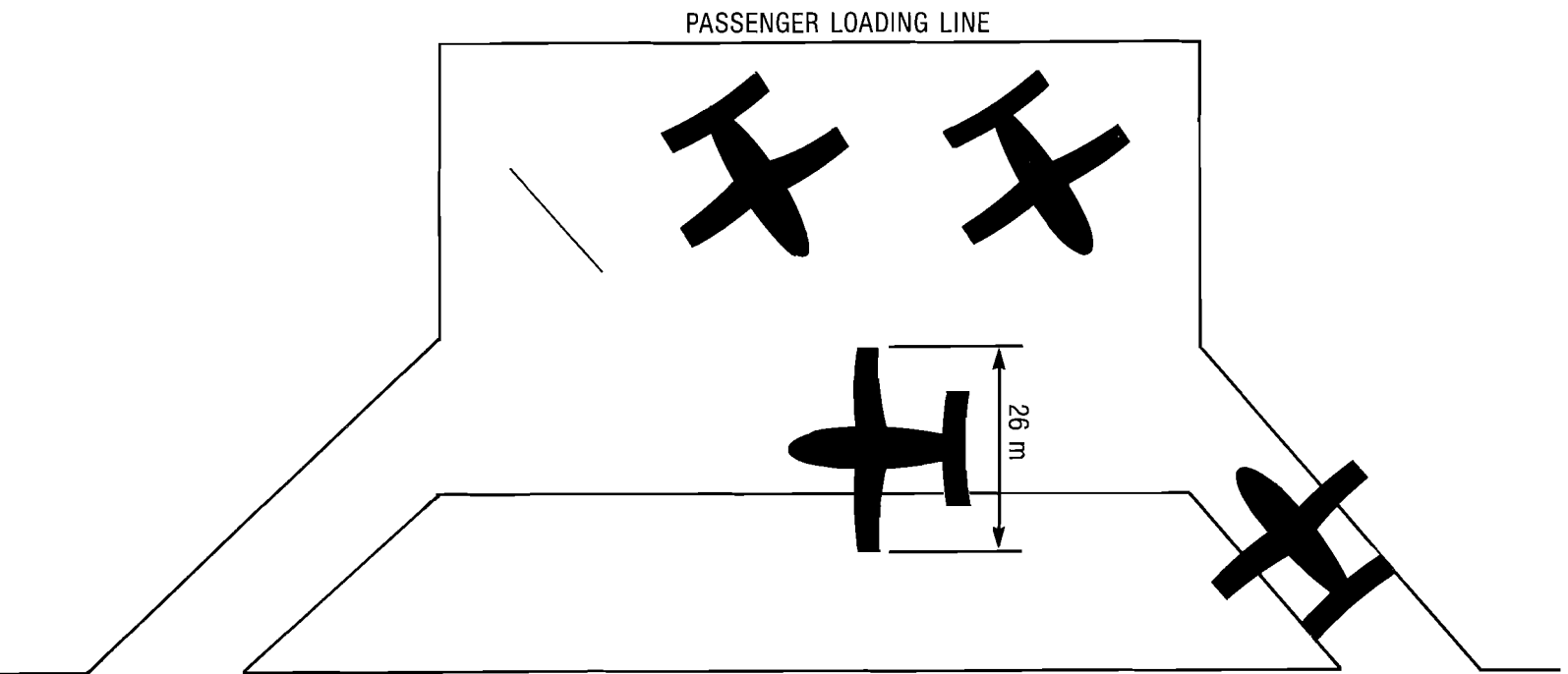

Figure 3-2. Typical stopport apron

# Chapter 4

## Obstacle Limitation Surfaces

### 4.1 GENERAL

4.1.1 Obstacle limitation surfaces are established to define the airspace over and around a stolport that must be kept free of obstacles. The limitation surface sets out the limits above which objects should not extend.

4.1.2 In the planning and design of a stolport, obstacle limitation surfaces require careful consideration. In fact, the presence of objects located in the vicinity or planned for construction near an otherwise suitable stolport site may be the overriding factor in whether a stolport will be a realistic project. The operation of a stolport may be significantly affected by features beyond the stolport boundary such as buildings, bridges and towers. Objects that penetrate the obstacle limitation surfaces described in this chapter may, therefore, impose take-off mass limitations, cause an increase in weather minima or both. They may also necessitate the displacement of the threshold.

4.1.3 Once a commitment is made to the establishment of a stolport, the sectors of the local airspace covered by the obstacle limitation surfaces should be regarded as integral to the stolport and therefore inviolable. Consequently, enactment of zoning legislation may be needed to preserve unobstructed airspaces for take-off, approach, missed approach and circling procedures. Legislation aside, the stolport authorities should be involved in community consultation and should maintain close liaison with local development planners to ensure that stolport requirements are included in forecasts and well integrated into plans.

4.1.4 Stolport obstacle limitation surface requirements are normally set on the assumption that take-offs and landings will be made in both directions. Therefore the functions of surfaces may be integrated and the requirements of one surface nullified because of the more stringent requirements of another.

4.1.5 The obstacle limitation surfaces to be defined at a stolport will depend on terrain and the type of operation

envisaged at the stolport. At the very minimum, for day-time operations in visual meteorological conditions, the surfaces requiring protection are the take-off and approach surface and the transitional surface. For use at night and when a circling procedure as part of an instrument approach is established, an inner horizontal surface will require protection as well.

4.1.6 Obstacles which penetrate the obstacle limitation surfaces described in this chapter may, in certain circumstances, cause an increase in the obstacle clearance altitude/height for an instrument approach procedure or any associated visual circling procedure. Criteria for evaluating obstacles are contained in the *Procedures for Air Navigation Services — Aircraft Operations (PANS-OPS)* (Doc 8168), Volume II — *Construction of Visual and Instrument Flight Procedures*.

### 4.2 TAKE-OFF AND APPROACH SURFACES

(See Figure 4-1)

#### 4.2.1 General

4.2.1.1 Description — Take-off surface. An inclined plane or other specified surface beyond the end of a runway.

4.2.1.2 Description — Approach surface. An inclined plane or combination of planes preceding the threshold.

4.2.1.3 Take-off and approach surfaces should be established for each stolport runway direction. Unless operations on a runway are restricted to take-off and landing in one direction only, the approach surface and the take-off surface will normally be combined.

#### 4.2.2 Take-off and approach surface boundaries

4.2.2.1 The take-off and approach surface should comprise:

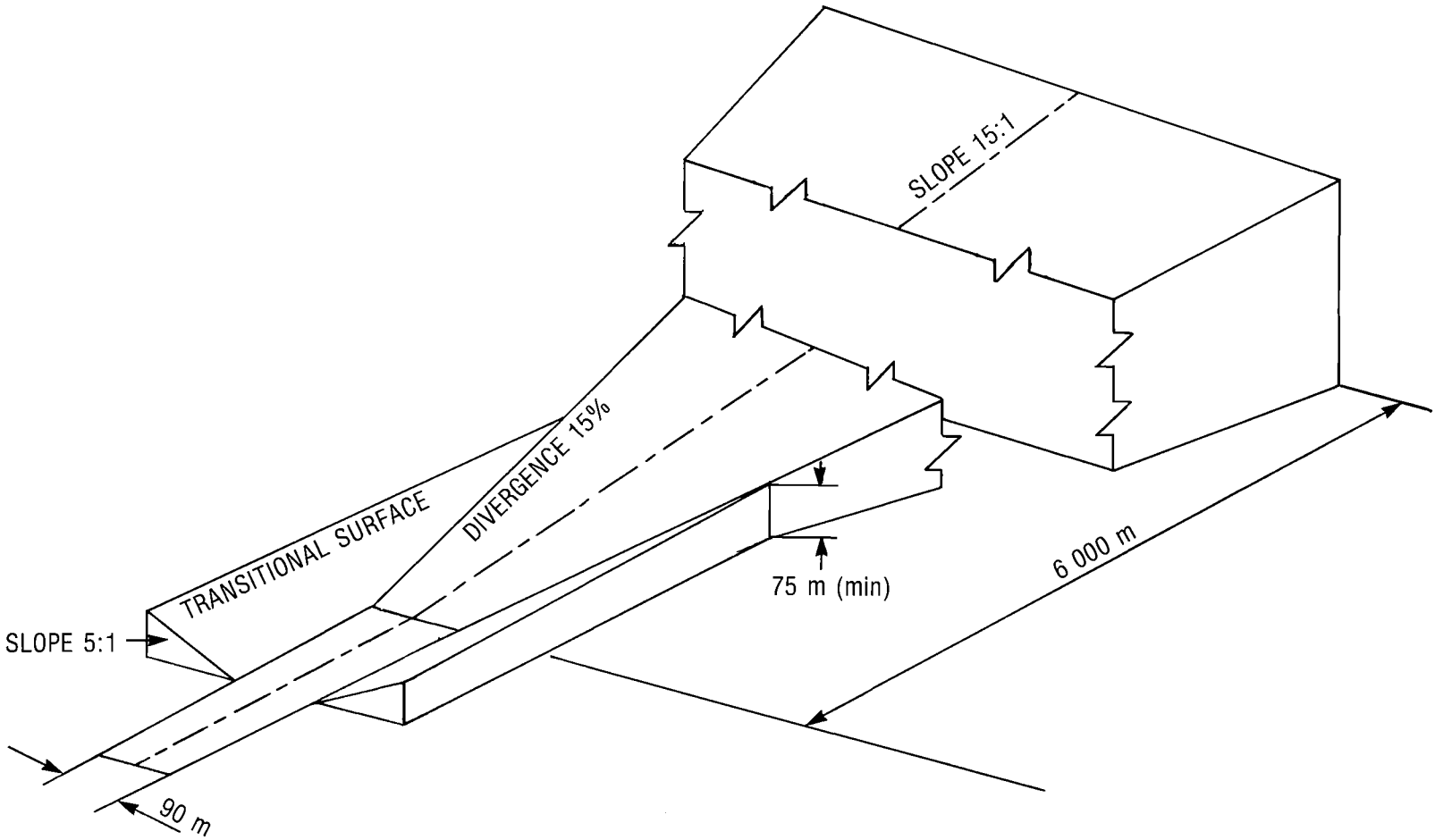

Figure 4-1. Composite approach/departure surface

- a) an inner edge of specified length, horizontal and perpendicular to the centre line of the runway and located at the end of the runway strip;
- b) two sides originating at the ends of the inner edge diverging uniformly at a specified rate to a final width that will be the product of the divergence and the length of the area and continuing thereafter at that width for the remainder of the length of the take-off and approach area; and
- c) an outer edge parallel to the inner edge.

4.2.2.2 These area parameters are based on a straight-in final approach track and a straight take-off climb track. Offset, curved or segmented tracks would require modification of the area boundaries.

#### 4.2.3 Take-off and approach surfaces/slopes

4.2.3.1 The take-off and approach surfaces should comprise:

- a) an inclined plane that establishes the height limitations of objects; and
- b) an inclined plane of a slope specified in 4.2.4.1 bound by the inner edge at the elevation of the threshold, two diverging sides and the outer edge.

4.2.3.2 In certain cases, because of slopes, portions of the inner edge may be below the runway strip elevation. In such cases, it is not necessary to grade the strip to conform to the inner edge of the approach surface. Nor is it intended that objects or terrain that are above the approach surface beyond the end of the strip but below the level of the strip be removed unless they constitute a danger to aeroplanes.

4.2.3.3 The maximum slope for a take-off surface should be determined using the aeroplane flight manual performance data for the stolport design aeroplane.

4.2.3.4 The maximum slope for an approach surface should be governed by the approach angle the design aeroplane is able to maintain in the landing configuration.

#### 4.2.4 Dimensions of take-off and approach surfaces

4.2.4.1 Suggested criteria for take-off and approach surfaces are as follows:

Length of inner edge: 90 m  
Divergence: 15 per cent

Length: 6 000 m

Slope: Determined by design aeroplane performance (typically 6 per cent or 1 in 15).

These criteria are based on a typical STOL aeroplane's second segment climb, one engine inoperative, to an en route safe altitude or to the take-off power time limitation (sea level, standard atmosphere).

4.2.4.2 The foregoing criteria are suggestions based on typical circumstances but, since various aeroplanes will have different achievable angles of approach and departure, obstacle limitation surfaces may be fashioned to suit the site keeping in mind the obstacles in the vicinity and the capabilities of the stolport design aeroplane. For example, it is not always necessary to aim for a 6 degree approach angle. A site may accept some shallower angle but still provide the needed length of usable runway. On the other hand, an approach angle of more than 6 degrees may be required to make possible an adequate runway length.

### 4.3 TRANSITIONAL SURFACES

#### 4.3.1 General

To ensure safe transitions for low altitude operation during approach and missed approach phases a transitional surface should be established for each runway direction.

#### 4.3.2 Characteristics of a transitional surface

4.3.2.1 The limits of a transitional surface should comprise:

- a) a lower edge beginning at the intersection of the side of the approach surface with the inner horizontal surface (if any) and extending down the side of the approach surface to the inner edge of the approach surface and from there along the length of the strip parallel to the runway centre line; and
- b) an upper edge located in the plane of the inner horizontal surface or 75 m above the stolport elevation if no outer surface has been set.

4.3.2.2 The elevation of a point on the lower edge should be:

- a) along the side of the approach surface — equal to the elevation of the approach surface at that point; and

- b) along the strip — equal to the elevation of the nearest point on the centre line of the runway.

4.3.2.3 A transitional surface slope of 20 per cent (1 in 5) measured in a vertical plane perpendicular to the centre line of the runway has been found to be adequate.

4.3.2.4 The slope of a transitional surface may be increased to a maximum of 50 per cent (1 in 2) where:

- a) obstacles that are deemed critical and that penetrate a 20 per cent slope are suitably marked and lighted;
- b) landing and take-off limits are set high enough to ensure that at decision height or at the beginning of take-off any object penetrating a 20 per cent slope is clearly visible;
- c) only precision approaches are permitted in IMC;
- d) the steeper slope extends only to the governing obstacle with the slope thereafter to the inner horizontal surface being 20 per cent; and
- e) use of the stolport is restricted to VMC when the required visual and non-visual aids are unserviceable.

#### 4.4 INNER HORIZONTAL SURFACES

##### 4.4.1 General

Where it is necessary to provide for circling approach procedures an inner horizontal surface should be

established. Where an inner horizontal surface overlaps a take-off and approach surface, the inner horizontal surface will be the more restrictive or governing surface.

##### 4.4.2 Characteristics of an inner horizontal surface

4.4.2.1 The radius or outer limits of an inner horizontal surface should be at least 3 000 m measured from the stolport reference point. The shape of an inner horizontal surface need not necessarily be circular.

4.4.2.2 An inner horizontal surface should be a common plane at a constant height of 75 m above the elevation of the stolport reference point or the elevation of the highest permanent structure within the area of the inner horizontal surface, whichever is higher, but not exceeding 120 m.

4.4.2.3 Where the height of the inner horizontal surface is less than 9 m above the surface of the ground an imaginary surface located at 9 m should be established.

4.4.2.4 Where the height of the inner horizontal surface would exceed 120 m on one side of the runway a semi-circular inner horizontal surface may be possible permitting a circling approach procedure on the other side of the runway. Where this is not possible, circling as part of an approach procedure should not be designed. Thus the need for an inner horizontal surface would be eliminated.

# Chapter 5

## Visual Aids for Navigation

### 5.1 GENERAL

5.1.1 The visual aids provided at a stolport must serve two functions:

- a) to provide the pilot with the elements of guidance required to execute safe operations at the stolport; and
- b) to allow the pilot, by the utilization of lighting and marking, a means to quickly identify the runway as being designed for STOL operations as opposed to CTOL operations.

5.1.2 At conventional airports, it is possible that special runways exclusively for use by STOL aircraft may be constructed to increase the air traffic capacity of the airport and to reduce STOL aircraft block times. A need will exist to differentiate such special runways from those intended for use by aeroplanes requiring longer landing distances. Stolports located in cities will also require special marking and lighting to make them easily identifiable in the midst of the cities' lights and other features.

5.1.3 The air traffic control procedures and methods of operation of STOL aircraft may also have an influence on the design of the visual aids. Where a runway is meant for use by conventional as well as STOL aeroplanes, marking and lighting should be in accordance with Annex 14, Volume I, Chapter 5.

### 5.2 MARKINGS, GENERAL

5.2.1 The markings described in this chapter are suitable for stolport operations in both visual and instrument meteorological conditions. Markings should be conspicuous and provide the maximum possible contrast under various conditions.

5.2.2 Runway markings should be white; taxiway and aircraft stand markings should be yellow and of a consistency that will reduce the risk of uneven braking.

### 5.3 RUNWAY MARKINGS

#### 5.3.1 Stolport designation marking

Where it is necessary to ensure that pilots can distinguish it from a conventional runway a stolport runway should be identified by the letters STOL across each end of the runway. Guidance on the form and dimensions of the letters are set out in Figure 5-1.

#### 5.3.2 Threshold marking

5.3.2.1 A runway threshold should be marked as follows:

- a) where the runway is marked with a stolport designation — a solid white band 1.5 m wide commencing at the runway end and extending across the full width of the runway; or
- b) where the runway is not marked with a stolport designation — a series of white stripes 15 m long, 1.8 m wide, spaced 1.8 m apart located at the runway end.

5.3.2.2 Where the threshold of a stolport runway is a displaced threshold, the beginning of the stolport runway should be indicated by a transverse stripe at least 1.8 m wide. The portion of the runway before the displaced threshold should be marked with arrows and all other markings should be obliterated.

5.3.2.3 The arrows leading to a displaced threshold should be spaced at intervals of 30 m with the point of the arrow immediately preceding the displaced threshold at 30 m from the transverse stripe. Guidance on the form and dimensions of the arrows are set out in Figure 5-2.

#### 5.3.3 Runway designation marking

A runway designation marking should be provided at the threshold of a runway. It should consist of a two-digit

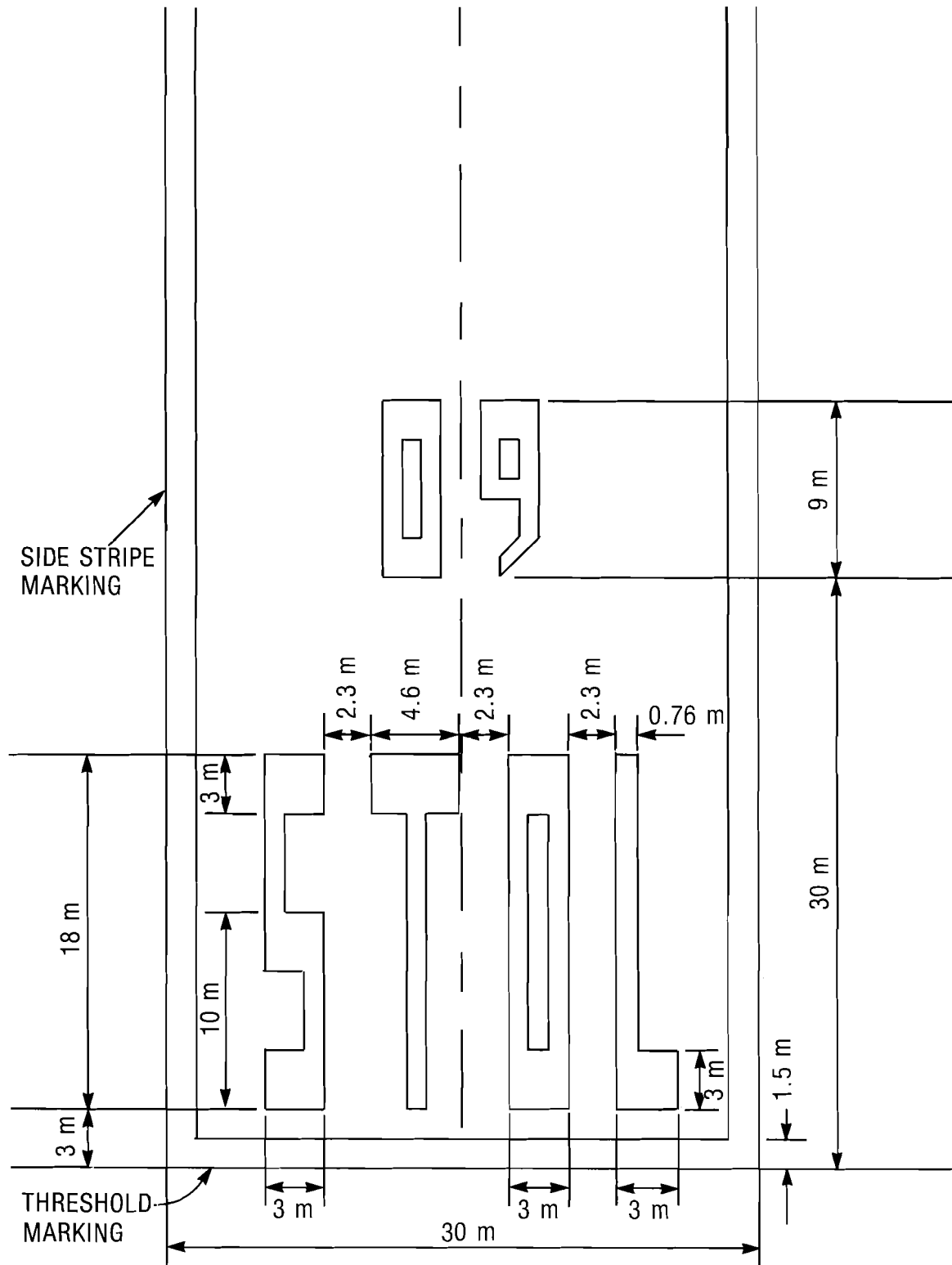

Figure 5-1. Stolport designation and runway threshold marking

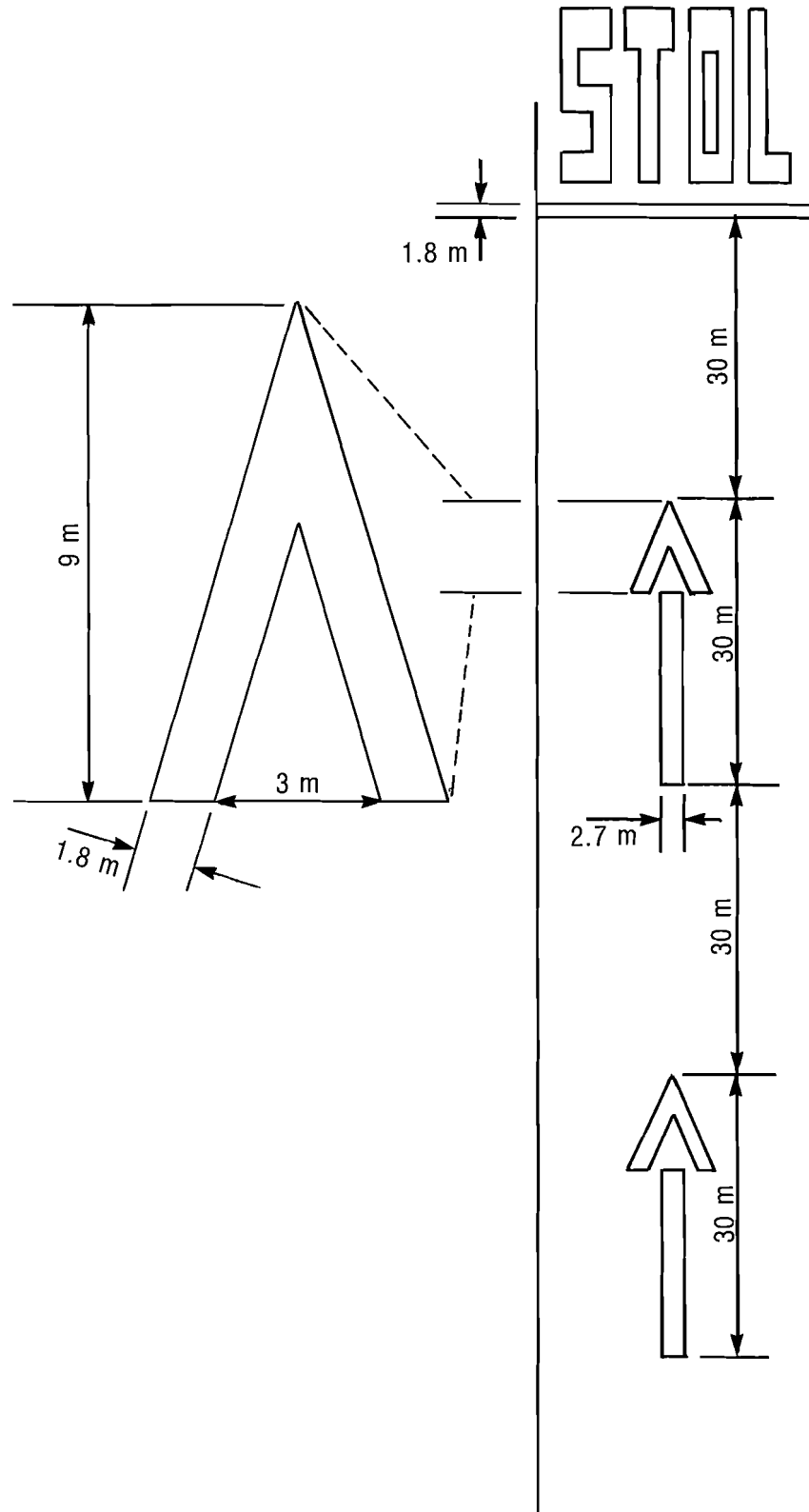

Figure 5-2. Displaced threshold markings



number that is the whole number nearest the one tenth of the magnetic azimuth of the centre line of the runway measured clockwise from magnetic north when viewed from the direction of approach. However, where a stolport is located in an area of compass unreliability a runway designation marking should display true azimuth rather than magnetic azimuth. Forms and proportions of runway designation markings are shown in Figure 5-3.

#### 5.3.4 Runway centre line marking

A stolport runway centre line marking should consist of an interrupted line of longitudinal stripes beginning 23 m from the runway designation marking as shown in Figure 5-4. The length of a stripe should be 15 m and the gap between stripes should be 15 m. The stripes should be at least 45 cm wide.

#### 5.3.5 Runway side stripe marking

A runway side stripe marking is considered essential for a stolport runway. It should consist of a 90 cm wide stripe located at each edge of the runway for its full length as shown in Figure 5-1.

#### 5.3.6 Touchdown zone marking

A stolport touchdown zone marking should consist of two white rectangles at least 22.5 m long and 1.8 m wide as shown in Figure 5-4. The marking should be located symmetrically about the centre line of the runway and at a distance from the threshold that coincides with the glidepath origin and visual approach slope indicator location, if provided.

#### 5.3.7 Runway exit marking

When a runway exit marking is provided, it should consist of a continuous yellow line 15 cm wide parallel to and 1.8 m from the runway centre line marking for 30 m curving at a specified radius to join the taxiway centre line as shown in Figure 5-4. The turning radii for the curves of a runway exit marking should be as follows:

- a) exits at the ends of a runway — 45 m;
- b) 45 degree exits — 90 m;
- c) 90 degree exits — 30 m; and
- d) 135 degree exits — 30 m.

Runway exit markings should ensure the minimum wheel to taxiway edge clearance mentioned in Chapter 3, 3.4.1.2 of this manual.

### 5.4 TAXIWAY MARKING

The taxiway markings specified in Annex 14, Volume I, Chapter 5, are considered suitable for stolports.

### 5.5 WIND DIRECTION INDICATOR

The specifications for wind direction indicators in Annex 14, Volume I, Chapter 5, are considered suitable for stolports.

### 5.6 STOLPORT LIGHTING

#### 5.6.1 General

5.6.1.1 Stolport lighting should provide effective and safe visual guidance during take-off, approach, landing and ground manoeuvring in conditions of minimum visibility and at night. This requirement is best met by a straightforward system of component elements, the spacing and intensity of which are balanced and consistent so that the pilot encounters a pattern that is recognizable as the expected standard stolport system. The lighting system detailed in this manual has been designed to support operations down to precision approach Category I minima. The approach angle for which the system has been optimized is 6 degrees.

5.6.1.2 Specifications for the photometric characteristics and setting angles of various elements of stolport lighting will vary according to such factors as stolport environment, ambient light, stolport design aeroplane type and approach path angle. Typical recommended characteristics are shown in Table 5-1.

5.6.1.3 A stolport designed for use at night in visual meteorological conditions should be equipped with at least the following lighting facilities:

- a) high-intensity runway edge lights;
- b) high-intensity runway threshold and runway end lights;
- c) medium-intensity taxiway edge lights;

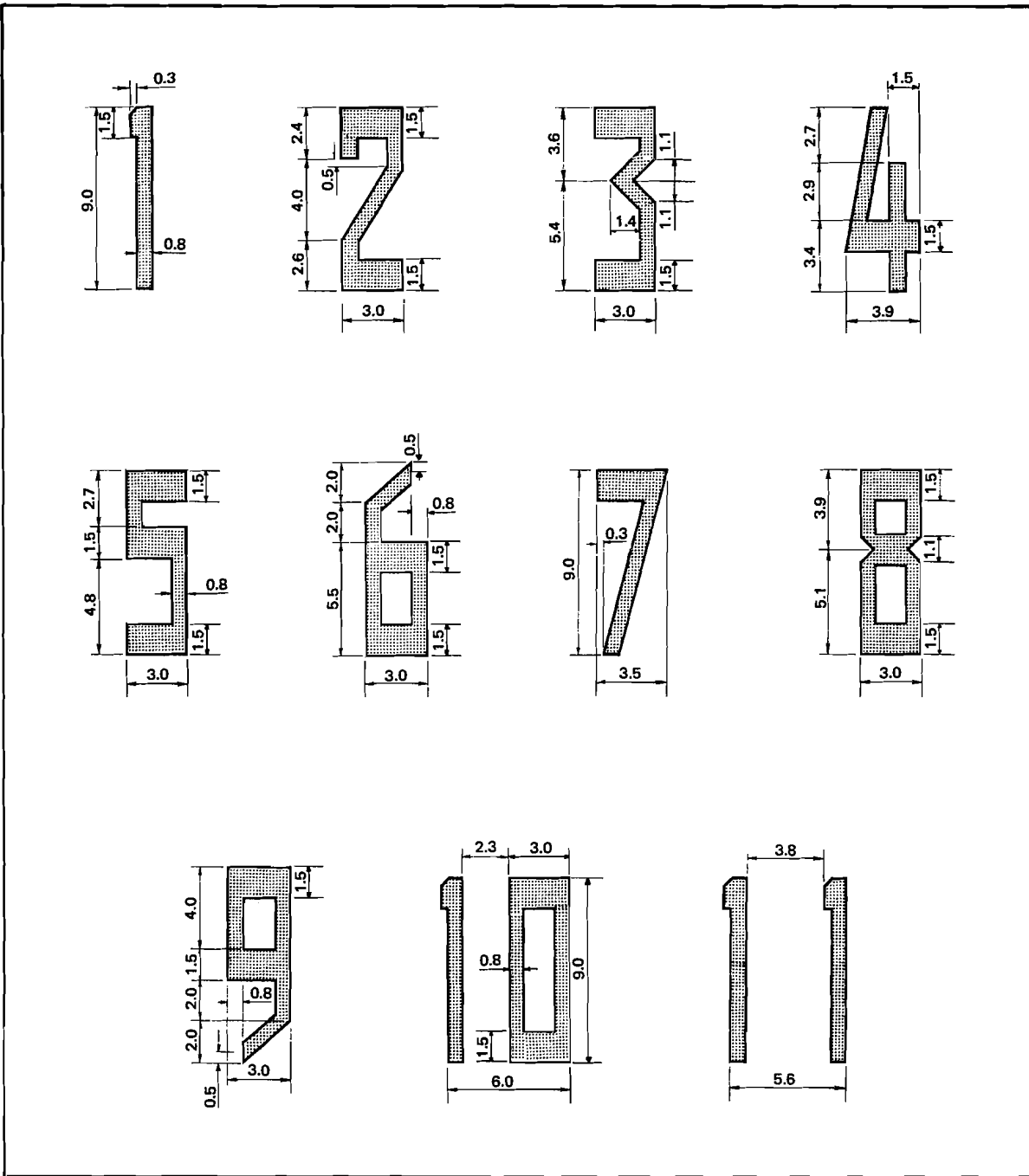

Figure 5-3. Form and proportions of runway designation numbers (in metres)

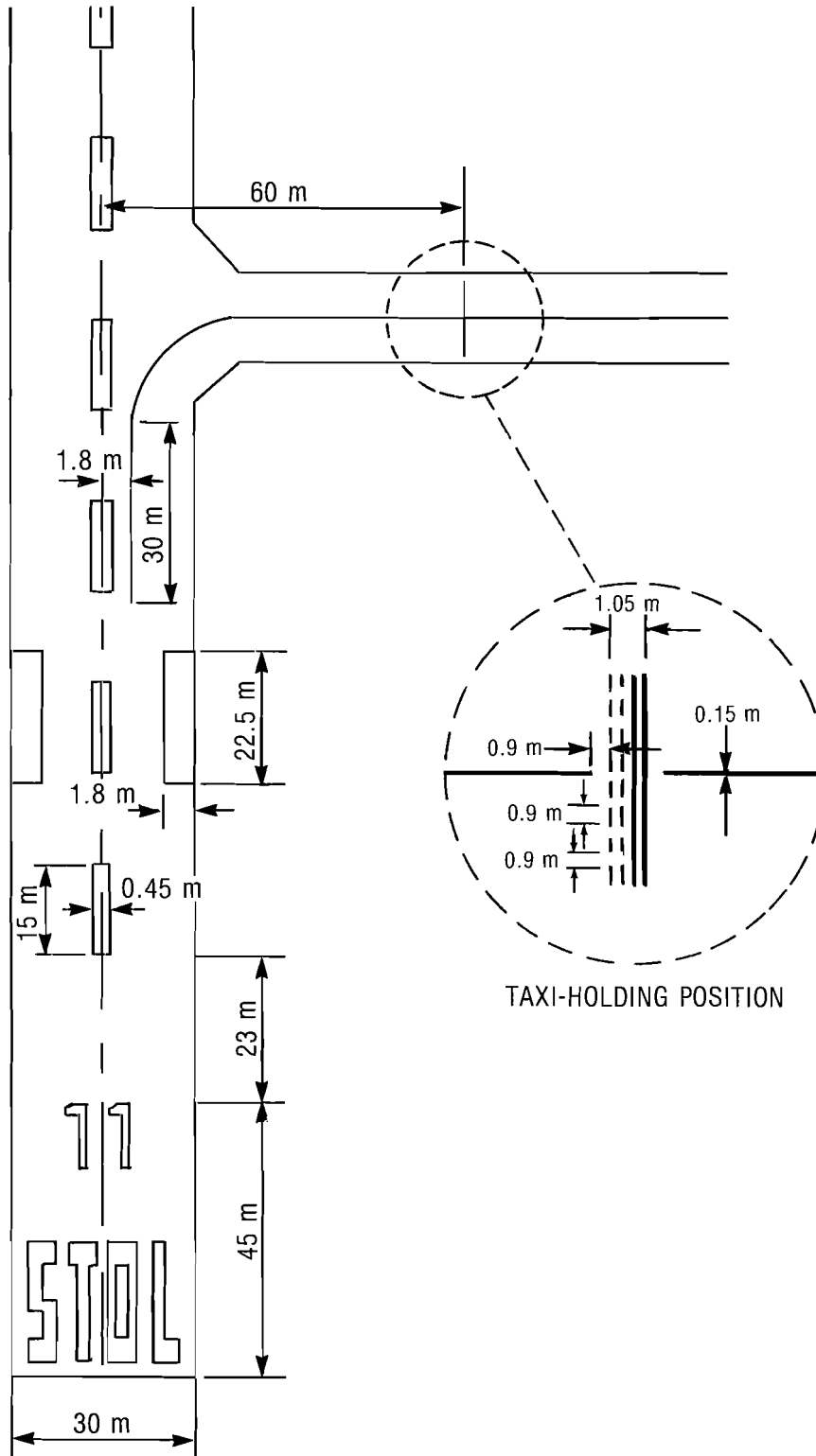

Figure 5-4. Runway and taxiway markings

Table 5-1. Characteristics of stolport light units

<i>Light unit</i>	<i>Type</i>	<i>Colour</i>	<i>Minimum average intensity cd × 1 000</i>	<i>Minimum beam dimension (degrees)</i>		<i>Main beam angular setting (degrees)</i>		<i>Remarks</i>
				<i>Horizontal</i>	<i>Vertical</i>	<i>Elevation</i>	<i>Angle to C/L</i>	
High intensity approach lights	Unidirectional	White	20	21	12	12		
Runway identification lights	Unidirectional	White	11	25	25	7.5	20 divergence	60 to 120 CPS
Runway edge	As required	White	10	5	4	4.5	4.5 convergence	
Runway threshold	Bidirectional	Green — approach;	10	5	4	4.5	4.5 convergence	Factor 0.130 for Red; 0.150 for Green.
Runway end		Red — runway;						
Taxiway edge:								
Straight	Bidirectional	Blue	2	3	2	4.5	3 convergence	Factor 0.022 for Blue
Curved	Omni-directional	Blue	2	360	6	3		
Touchdown zone	Floodlight	White	19	60	6			Light beam to be projected on touchdown zone.

- d) visual approach slope indicator system;
- e) lighted wind direction indicator; and
- f) apron lighting.

5.6.1.4 In addition to the foregoing requirements, if a stolport is designed for use in instrument meteorological conditions, the following facilities may be operationally necessary:

- a) high-intensity approach lights;
- b) runway identification lights;
- c) touchdown zone lights; and
- d) stolport beacon.

### 5.6.2 Dangerous and confusing lights

Any light on or in the vicinity of a stolport that constitutes a danger to aircraft should be removed or modified to eliminate the source of danger. Any non-aviation ground light located in the approach area of a stolport that might cause confusion because of intensity, colour or configuration should be removed or modified to eliminate the source of confusion. Ground lights of a stolport located near navigable waters should be installed so as not to confuse mariners.

### 5.6.3 Light fixtures and supporting structures

Elevated approach light fixtures should be mounted on lightweight, frangible supporting structures. Elevated runway, threshold and taxiway lights should be sufficiently low to clear aircraft components and should be frangibly mounted. The *Aerodrome Design Manual*, Part 4, gives guidance on frangibility of light fixtures and supporting structures.

### 5.6.4 Light intensity and control

5.6.4.1 To allow for adjustment of light intensity to meet prevailing conditions, intensity should be controllable, with separate intensity controls provided to ensure that the following systems can be operated at consistent intensities:

- a) approach lighting system (if provided);
- b) runway edge lights;

- c) runway threshold lights;
- d) runway end lights; and
- e) touchdown zone lights (if provided).

5.6.4.2 A high intensity lighting system should have an intensity control with 5 settings that control the percentage of light output as follows:

- setting 5: 100 per cent
- setting 4: 25 per cent
- setting 3: 5 per cent
- setting 2: 1 per cent
- setting 1: 0.2 per cent

### 5.6.5 Stolport beacon

5.6.5.1 A stolport beacon should be provided except where deemed unnecessary in view of the requirements of stolport air traffic, the prominence of the stolport against its background and features of other visual aids that help locate the stolport. Where provided, a stolport beacon should be located on or adjacent to the stolport.

5.6.5.2 The upper angle elevation and the average intensity of a stolport beacon will vary according to the stolport environment, but where used the light from the beacon should normally show at all angles of azimuth and from an elevation of not more than 1 degree. An intensity of 50 000 candelas may be appropriate.

5.6.5.3 A stolport beacon should show alternating white flashes at a frequency of at least 20 flashes per minute and should be coded with the International Morse Code letter S, to denote “Stolport”.

### 5.6.6 Approach lighting system

5.6.6.1 The decision whether to provide an approach lighting system will depend on the location and environment of the stolport and on the approach slope angle. At a decision height of 200 feet (60 m) on a 6 degree approach, for example, the aeroplane would be about 580 m from touchdown and about 475 m from the threshold. If the visibility limit for the approach was in the order of 800 m, the pilot would have the runway environment in sight. Guidance would be provided by runway threshold and edge lights (possibly supplemented by runway identification lights) and visual approach slope indicator. Little of the approach lighting system would be perceived. Nevertheless, at lesser angles of approach, where extraneous light

patterns may be confusing or where offset or segmented curved approach paths are used it may be advisable to provide approach lighting.

5.6.6.2 Where an approach lighting system is provided it should be designed to give guidance day and night in the most adverse conditions and ambient light under which it is intended that the stolport remain usable.

5.6.6.3 A stolport approach lighting system should consist of a row of lights on the extended runway centre line extending, whenever possible, over a distance of 300 m from the runway threshold with a row of lights forming a crossbar 30 m in length at a distance of 150 m from the threshold (see Figure 5-5).

5.6.6.4 The lights forming the crossbar should be in a horizontal straight line at right angles to and bisected by the extended runway centre line. The lights forming the crossbar should be spaced to give a linear effect except that a gap not exceeding 6 m may be left on each side of the centre line.

5.6.6.5 The lights forming the centre line should be placed at longitudinal intervals of 15 m. The innermost light should be located 15 m from the threshold.

5.6.6.6 The approach lighting system should lie in a horizontal plane passing through the threshold, provided that:

- a) no lights should be screened from approaching aircraft; and
- b) no object should protrude through the plane of the approach lights within 60 m of the centre line. Where this is unavoidable, as in the case of an isolated navigation aid, the object should be treated as an obstacle and marked and lighted accordingly.

5.6.6.7 The lights of an approach lighting system should be fixed white lights. Each centre line light should consist of either:

- a) a single light source; or
- b) a barrette at least 3 m long.

5.6.6.8 Where identification of the stolport approach lighting system is difficult owing to surrounding lights or where the final approach path is offset or segmented, augmentation or substitution of the system by sequence flashing runway lead-in lights may prove useful.

5.6.6.9 Where circling procedures or visual circuits are authorized, the approach lights should show at all angles in azimuth necessary to conduct such procedures.

5.6.6.10 Installation tolerances for approach lighting systems are given in Annex 14, Volume I, Attachment A, Section 11. These will need to be appropriately adjusted taking into account the reduced light spacing used in respect of stolports.

### 5.6.7 Visual approach slope indicator system

5.6.7.1 In short-field operations it is essential that the pilot follow an accurate approach path leading to the proper touchdown point for landing. Accordingly, the precision instrument glide slope of a stolport runway should be augmented with a visual approach slope indicator system (PAPI or APAPI). When the runway is equipped with a precision approach, the siting and the angle of elevation of the light units should be such that the visual approach slope conforms as closely as possible with the glide path of the precision approach.

5.6.7.2 A stolport PAPI system should consist of a wing bar of four sharp transition multi-lamp or paired units spaced equally. The system should be located on the left side of the runway, unless it is impracticable to do so (see Figure 5-6).

5.6.7.3 A stolport APAPI system should consist of a wing bar of two sharp transition multi-lamp or paired units, and located on the left side of the runway, unless it is impracticable to do so (see Figure 5-6).

5.6.7.4 Where approach lights and runway marking and lights give insufficient roll guidance, a second wing bar on the other side of the runway may be useful.

5.6.7.5 A wing bar of a PAPI should be made up so that a pilot on approach will:

- a) when on or close to the approach slope, see the two units nearest to the runway as red and the two units farthest from the runway as white;
- b) when above the approach slope, see the one unit nearest to the runway as red and the three units farthest from the runway as white; and, when further above the approach slope, see all the units as white; and
- c) when below the approach slope, see the three units nearest the runway as red and the one unit farthest from the runway as white; and, when further below the approach slope, see all the units as red.

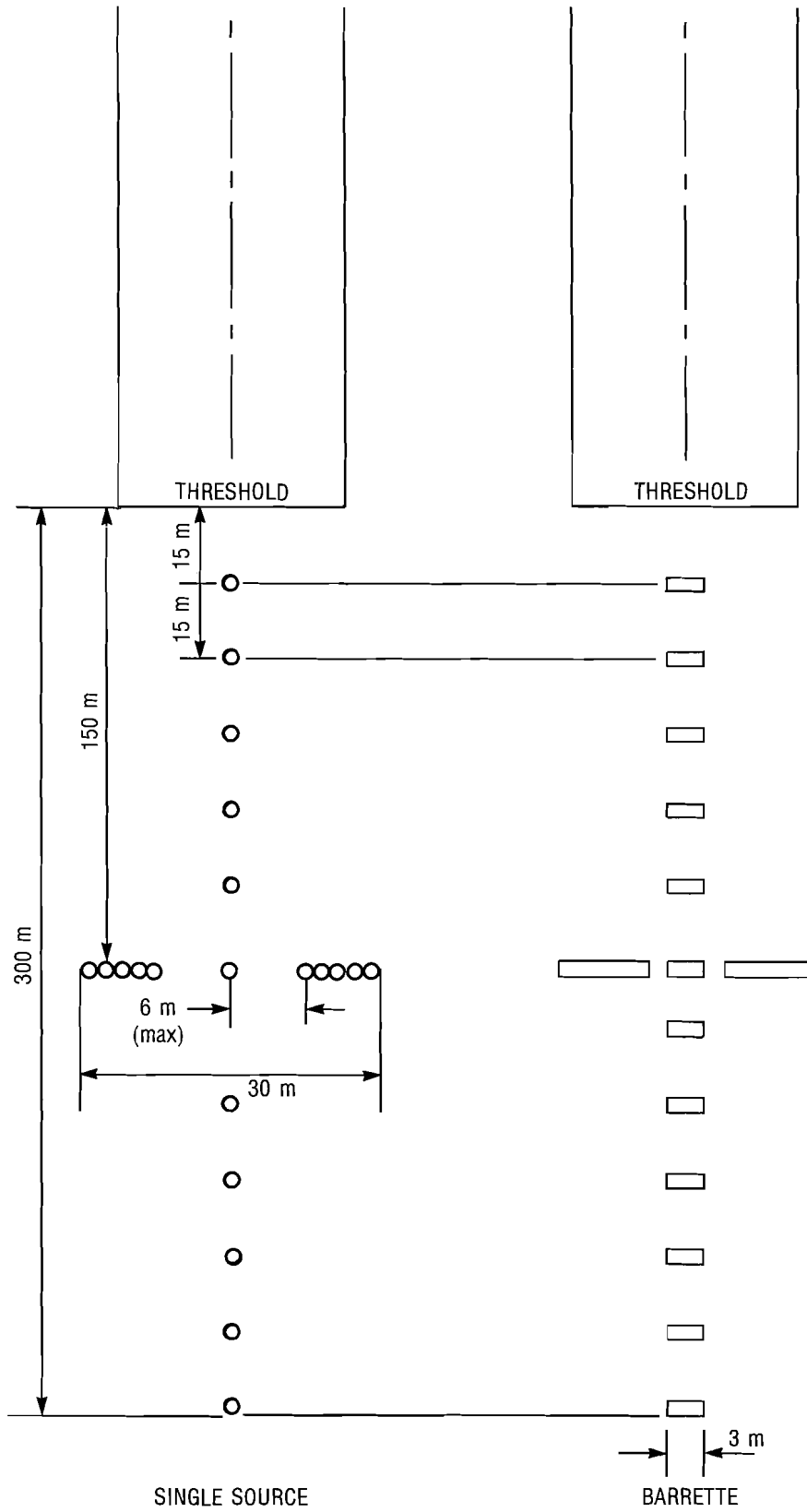

Figure 5-5. Stolport approach lighting system

5.6.7.6 A wing bar of an APAPI should be made up so that a pilot on approach will:

- a) when on or close to the approach slope, see the unit nearer the runway as red and the unit farther from the runway as white;
- b) when above the approach slope, see both units as white; and
- c) when below the approach slope, see both units as red.

5.6.7.7 The system should be suitable for both day and night operations.

5.6.7.8 The colour transition from red to white in the vertical plane should appear to an observer, at a distance of not less than 300 m, to occur up to a vertical angle of not more than 3°. At full intensity the red light should have a Y coordinate not exceeding 0.320. The light intensity distribution of the light units should be as shown in Figure 5-7. Each light unit should be adjustable in elevation so that the lower limit of the white part of the beam may be fixed at any desired angle between 4°30' and 7°30' above the horizontal.

5.6.7.9 Deposits of extraneous substances like snow, ice, condensation or dirt on optically transmitting or reflecting surfaces should not affect the contrast between red and white or the elevation of the transition sector.

5.6.7.10 The aiming of light units is shown in Figure 5-8. Differential setting angles of 30' are considered adequate for approach slopes of 4° to 6°. Approach slopes greater than 6° should be defined by differentials of one degree to facilitate capture and steep-approach flyability.

5.6.7.11 The *Aerodrome Design Manual*, Part 4, gives additional guidance on the characteristics of light units.

5.6.7.12 The angle of elevation settings of the light units in a PAPI wing bar should be such that, during an approach, the pilot of an aircraft observing a signal of one white and three reds will clear all objects in the approach area by a safe margin. The angle of elevation settings of the light units in an APAPI wing bar should be such that, during an approach, the pilot of an aircraft observing one white and one red will clear all objects in the approach area by a safe margin.

5.6.7.13 The system light units should be located in the basic configuration depicted in Figure 5-6.

5.6.7.14 The units forming the wing bar should be mounted so as to appear to the pilot of an aircraft on approach to be in a horizontal line. The light units should be mounted as low as possible and should be sufficiently light and frangible not to constitute a hazard to aircraft.

### 5.6.8 Runway lead-in lights

Runway lead-in lights may be provided where other visual aids give insufficient guidance. A runway lead-in lighting system should extend from a point appropriate to the approach path to a point where the runway environment is in view. Each group of lights of a runway lead-in system should consist of at least three flashing white lights in a linear or cluster configuration. The flashing lights in each group should flash in sequence towards the runway. The *Aerodrome Design Manual*, Part 4, gives guidance on providing lead-in lighting systems.

### 5.6.9 Runway threshold identification lights

5.6.9.1 Runway threshold identification lights should be provided at the threshold of a runway when additional threshold conspicuity is needed or where an approach lighting system is not provided.

5.6.9.2 Runway threshold identification lights should be located in line with the threshold and approximately 10 m outside each line of runway edge lights. They should be flashing white lights with a frequency of between 60 and 120 flashes per minute. The lights should be visible only in the direction of approach to the runway.

### 5.6.10 Runway edge lights

5.6.10.1 Runway edge lights should be located along the full length of the runway in two parallel, straight lines equidistant from the centre line. The lights should be located 1.5 m from the edge of the runway and the longitudinal distance between lights should be no more than 30 m. The lights on opposite sides of the runway axis should be on lines at right angles to that axis.

5.6.10.2 To alleviate snow removal problems during winter maintenance, the light units may be located up to 3 m from the runway edge and raised. The units, when raised, should be no higher than 35 cm above ground level at 1.5 m from the runway edge and 75 cm above ground level at 3 m from the runway edge. A minimum clearance of 15 cm should be maintained between raised light units and any overhanging part of the critical aeroplane when its main wheels are at the edge of the runway.



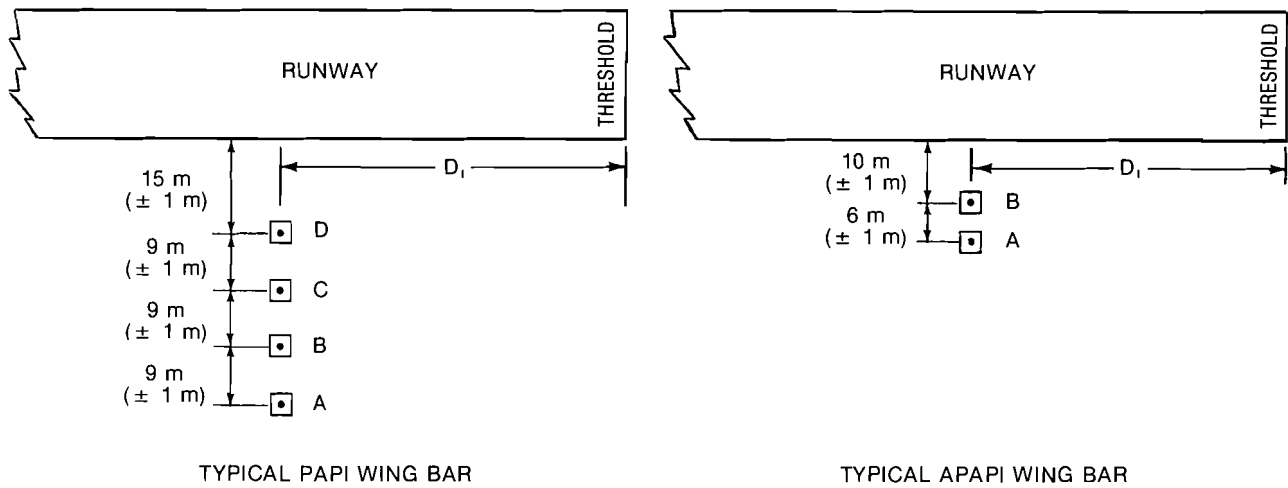

### INSTALLATION TOLERANCES

- a) The distance  $D_1$  should ensure that the lowest height at which a pilot will see a correct approach path indication will give the critical aeroplane a wheel clearance over the threshold of not less than 3 m or the aeroplane eye-to-wheel height in the approach attitude, whichever is greater.
- b) The distance  $D_1$  should equal the distance between the threshold and the effective origin of the non-visual glide slope.
- c) The distance  $D_1$  should compensate for differences in elevation between the wing bar and the runway centre-line and threshold.
- d) Small height adjustments of up to 5 cm between units is acceptable as is a lateral gradient not greater than 1.25 per cent applied uniformly across the units.
- e) Provided the reduction in usable range is acceptable, a spacing of 6 m ( $\pm 1$  m) between PAPI units may be used. In this case, the inner unit should be located 10 m ( $\pm 1$  m) from the runway edge.
- f) The lateral spacing between APAPI units may be increased to 9 m ( $\pm 1$  m) for greater range or if later conversion to PAPI is anticipated. The inner unit should then be located 15 m ( $\pm 1$  m) from the runway edge.

**Figure 5-6. Siting of PAPI and APAPI**

Degrees in elevation

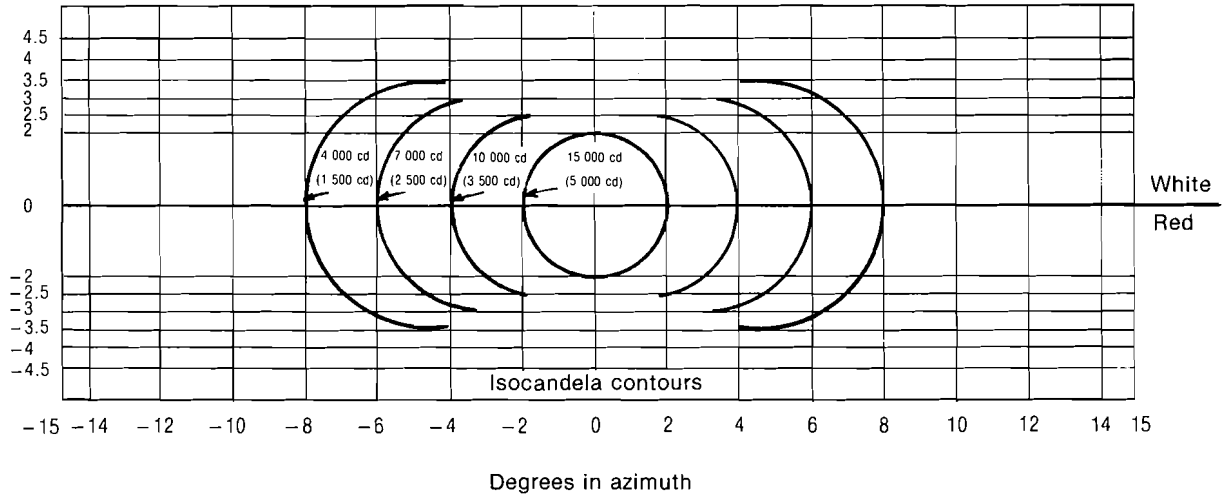

*Note 1.— These curves are for minimum intensities in red light.*

*Note 2.— The intensity value in the white sector of the beam is no less than 2 and may be as high as 6.5 times the corresponding intensity in the red sector.*

*Note 3.— The intensity values shown in brackets are for APAPI.*

**Figure 5-7. Light intensity and distribution of PAPI and APAPI**

5.6.10.3 Runway edge lights should be fixed lights showing variable white except that:

- a) where the threshold is displaced, the runway edge lights between the beginning of the runway and the displaced threshold should show red in the approach direction; and
- b) the section of runway edge lights one-third of the runway length before the runway end may show yellow.

5.6.10.4 Runway edge lights should show at all angles in azimuth necessary to provide guidance to a pilot landing or taking off in either direction. In all these angles of azimuth, runway edge lights should show at angles of elevation above the horizontal appropriate to the approach slope serving the stolport runway.

#### 5.6.11 Runway threshold lights

5.6.11.1 The threshold of a stolport runway should be indicated by six light units, three on each side of the centre line. The lights should be symmetrically located about the runway centre line at right angles to the runway axis and no more than 1.5 m from the extremity of the runway. The outermost lights of the two groups should be located 1.5 m outside the extended line of the runway edge with the remaining lights spaced at 4.5 m from the outermost light.

5.6.11.2 Runway threshold lights should be fixed unidirectional lights showing green in the direction of approach. The light units should have angles of elevation above the horizon appropriate to the approach slope serving the stolport runway.

5.6.11.3 Where a runway threshold coincides with the beginning of a stopway associated with the reciprocal runway, the threshold should be lighted in accordance with 5.6.12 below.

#### 5.6.12 Displaced runway threshold lights

Where the stolport runway threshold is a displaced threshold, it should be indicated by two wing bars symmetrically located on each side of the runway edge along the displaced threshold. Each wing bar of displaced runway threshold lights should consist of 3 green lights spaced 4.5 m apart with the innermost light located in line with the runway edge lights.

#### 5.6.13 Runway end lights

5.6.13.1 The end of a stolport runway should be indicated by six light units, three on each side of the centre line. Runway end lights should be symmetrically located about the runway centre line at right angles to the runway axis and no more than 1.5 m from the extremity of the runway. The outermost lights of the two groups should be located 1.5 m outside the extended line of the runway edge with the remaining lights spaced at 4.5 m from the outermost light.

5.6.13.2 Runway end lights should be fixed unidirectional lights showing red in the direction of take-off.

#### 5.6.14 Combined runway threshold and runway end lights

5.6.14.1 Where the runway threshold coincides with the reciprocal runway end, combined runway threshold and runway end lights may be used.

5.6.14.2 Combined runway threshold and runway end lights should be fixed bidirectional lights showing green in the direction of approach and red in the direction of take-off. The combined lights should be distributed about the runway threshold/end as described in 5.6.11.1.

5.6.14.3 The light units should have angles of elevation above the horizon appropriate to the approach slope serving the stolport runway.

#### 5.6.15 Stopway lights

5.6.15.1 Where a stopway is provided to accommodate the accelerate-stop distance required in a stolport's operation, the stopway should be provided with edge lights and end lights. Stopway edge lights should be placed along the length of the stopway in two rows coincident with the rows of the runway edge lights. Stopway end lights should be placed across the end of a stopway not more than 3 m outside the end.

5.6.15.2 Stopway lights should be fixed unidirectional lights showing red in the direction of the runway.

#### 5.6.16 Runway touchdown zone lights

5.6.16.1 In view of the touchdown accuracy required for STOL operations it is considered desirable to mark the

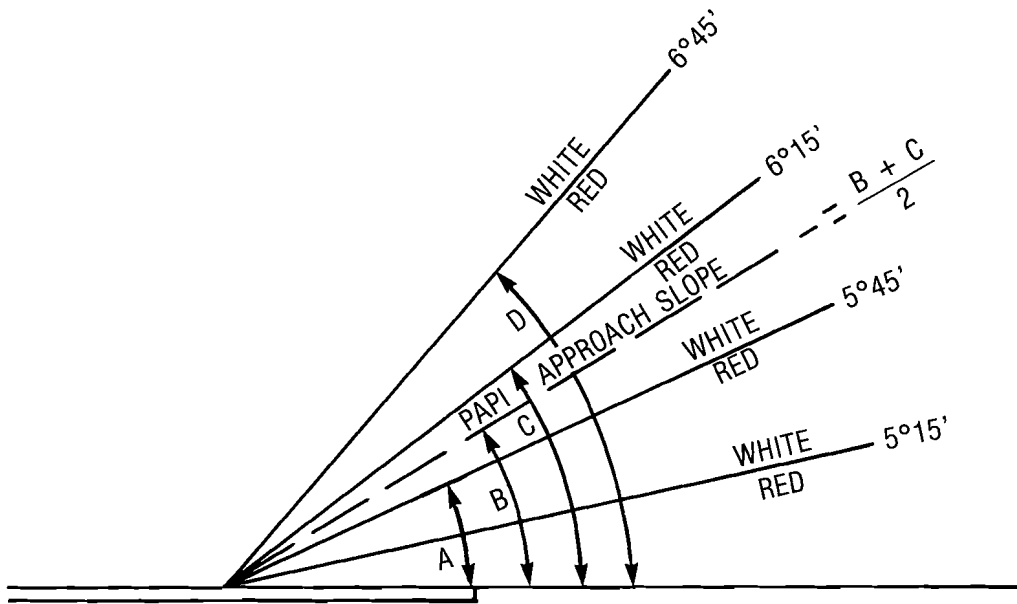

The height of the pilot's eye above the ILS/MLS glide slope aerial varies with the type of aeroplane and approach attitude. Harmonization of the PAPI signal and ILS/MLS glide slope to a point closer to the threshold may be achieved by increasing the on-slope sector from 30' to 40'. The setting angles for a 6° glide slope would then be 5°10', 5°40' 6°20' and 6°50'.

6° PAPI

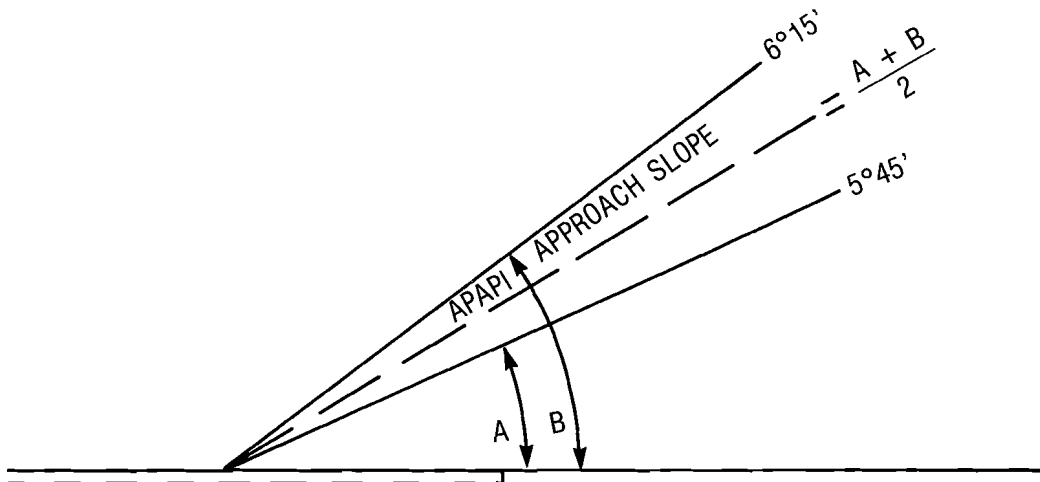

6° APAPI

Figure 5-8. Light beams and angle of elevation setting of PAPI and APAPI

touchdown zone with lights. A suitable method is the installation of a pair of white lights inset into the runway to mark the end of the touchdown zone.

5.6.16.2 A floodlit touchdown zone may assist in the flare and touchdown accuracy of some aeroplane types and may be used in addition to touchdown zone lights or as an alternative. Where it is decided to provide floodlighting, the touchdown zone should be illuminated with three floodlights on each side of the runway located laterally 6 m from the runway edge.

5.6.16.3 An average horizontal illuminance of 14 lux is considered adequate provided the uniformity ratio (average to minimum) is not more than 4 to 1. The illumination intensities and beam dimensions shown in Table 5-1 should give that value.

#### 5.6.17 Taxiway and apron lighting

The specifications in Annex 14, Volume I, Chapter 5, for taxiway edge lights, taxi-holding position lights and apron floodlighting are considered suitable for stolports. Further guidance on apron floodlighting is given in the *Aerodrome Design Manual*, Part 4.

#### 5.6.18 Aircraft control of lighting

5.6.18.1 In some circumstances it may be desirable to have stolport lighting controlled by aircraft radio. The following systems should be controllable:

- a) approach lights (if provided);
- b) runway edge, threshold and end lights;
- c) taxiway lights;
- d) visual approach slope indicator;
- e) runway identification lights; and
- f) wind direction indicator.

5.6.18.2 The radio control equipment should control the stolport lighting by decoding a series of radio signals generated by the clicking of an aircraft radio transmitter microphone. A procedure such as the following may be used.

Three microphone clicks: turns the stolport lighting on or, if already lighted, sets brightness to low.

Five microphone clicks: sets brightness to medium.

Seven microphone clicks: sets brightness to high.

The microphone clicks should occur within a five second period.

Brightness refers to intensities set for various aids in accordance with 5.6.4.1 and 5.6.4.2.

5.6.18.3 The stolport lighting system should turn off automatically 15 minutes after the latest control transmission.

## 5.7 SIGNS

### 5.7.1 General

5.7.1.1 Signs may be provided at a stolport to give information or instructions. The guidance on the sizes of signs, their inscriptions, methods of illumination, location, abbreviations commonly used and frangibility of signs given in the *Aerodrome Design Manual*, Part 4, is applicable to signs at stolports.

5.7.1.2 A sign should be located as near to the edge of the pavement as possible. Signs should be lightweight and frangibly designed and mounted sufficiently low to preserve clearance with any overhanging part of the critical aeroplane.

5.7.1.3 Only mandatory signs on a movement area should use the colour red for background. A sign should be legible from the cockpit of an aircraft at the farthest point of viewing. Where signs are provided for movement areas, they should be lit so as to be legible at night from a distance of 240 m with the sign's background colour readily discernable.

### 5.7.2 Mandatory instruction signs

5.7.2.1 A mandatory instruction sign should be provided where it is intended to identify, by a sign, a point beyond which aircraft or vehicular traffic shall not proceed without stolport control tower authorization. Mandatory instruction signs should comprise taxiway/runway intersection signs and NO ENTRY signs. A NO ENTRY sign should be located at the beginning of an area to which entry is prohibited.

5.7.2.2 A taxi-holding position marking should be supplemented with a taxiway/runway intersection sign. Wherever possible, taxiway/runway intersection signs and NO ENTRY signs should be located on each side of a taxiway facing the direction of approach to the runway or prohibited area. Where for some reason only one sign is utilized it should be located on the left side as viewed by the pilot.

5.7.2.3 A mandatory instruction sign should consist of a white inscription on a red background and should be illuminated when the stolport is designed for use at night or in low visibility conditions. Where applicable, the mandatory instruction sign inscriptions set forth in Annex 14, Volume I, Chapter 5, 5.4.2.12 should be used.

### 5.7.3 Information signs

5.7.3.1 Given the compressed area and simplicity of a typical stolport, little use of information signs is foreseen. Where required, an information sign should convey information such as a specific location or destination on a movement area. Whenever possible an information sign on a taxiway should be located on the left side of the taxiway.

5.7.3.2 An information sign should consist of either black inscriptions on a yellow background or yellow inscriptions on a black background and should be illuminated when the stolport is designed for use at night or in low visibility conditions.

## 5.8 MARKERS

### 5.8.1 General

Markers should be lightweight and frangibly mounted. Those located near a runway or taxiway should be sufficiently low to preserve clearance with any overhanging part of the critical aeroplane. Guidance on the frangibility of markers is given in the *Aerodrome Design Manual*, Part 4.

### 5.8.2 Unpaved runway edge markers

5.8.2.1 It is advisable to use markers to delineate the usable limits of a runway when the runway surface is gravel, turf, ice, or snow-covered. If flat rectangular markers are used, they should measure at least 1 m wide by 3 m long, and be placed with the longer dimension parallel to the runway centre line. If conical markers are used, they should not be more than 50 cm high.

5.8.2.2 Where runway edge lights are provided, the markers should be part of the light fixtures. Where there are no lights, markers of flat rectangular or conical shape should be located to delineate the runway limits clearly.

### 5.8.3 Edge markers for snow covered runways

5.8.3.1 When the limits of a snow covered runway are not otherwise indicated, it is recommended that edge markers should be provided. Edge markers for snow covered runways should be placed along the edges at intervals of not more than 100 m and far enough from the centre line to not interfere with aircraft on the runway. The threshold and end of the runway should be marked.

5.8.3.2 Evergreen trees 1.2 m to 1.5 m high or other conspicuous, lightweight markers are appropriate to be used as edge markers for snow covered runways.

### 5.8.4 Unpaved taxiway edge markers

5.8.4.1 Where the limits of an unpaved taxiway are not obvious, markers should be provided.

5.8.4.2 Where taxiway lights are provided, the markers should be part of the light fixtures. Where there are no lights, conical markers should be used to delimit the taxiway clearly.

# Chapter 6

## Visual Aids for Denoting Obstacles

### 6.1 OBJECTS TO BE MARKED AND LIGHTED

6.1.1 The marking and lighting of objects is intended to reduce hazards to aircraft by indicating the presence of obstacles. It does not necessarily reduce operating limitations that may be imposed by an obstacle.

6.1.2 A fixed obstacle that extends above an approach, transitional or take-off climb surface within 3 000 m of the inner edge should be marked and lighted except that:

- a) such marking and lighting may be omitted when the obstacle is shielded by another fixed obstacle; and
- b) the marking may be omitted when the obstacle is lighted by day by high intensity obstacle lights.

6.1.3 A fixed obstacle above an inner horizontal surface should be marked and lighted except that:

- a) such marking and lighting may be omitted when:
  - 1) the obstacle is shielded by another fixed obstacle;
  - 2) for an inner horizontal surface extensively obstructed by immovable objects or terrain, circling procedures have been established to ensure safe vertical clearance below the circling flight paths; or

3) the appropriate authority determines that the obstacle has no operational significance; and

- b) the marking may be omitted when the obstacle is lighted by day by high intensity obstacle lights.

6.1.4 Mobile equipment and vehicles, other than aircraft, on the movement area of a stolport are obstacles and should be marked and lighted except that equipment and vehicles used only on aprons may be exempt.

6.1.5 Elevated aeronautical ground lights within the movement area should be marked so as to be conspicuous by day.

6.1.6 All elevated objects within 26 m from the centre line of a taxiway should be marked and lighted.

6.1.7 All elevated objects within 24.5 m from the centre line of an aircraft stand taxilane should be marked and lighted.

### 6.2 MARKING AND LIGHTING OF OBJECTS

Objects should be marked and lighted in accordance with Annex 14, Volume I, Chapter 6, 6.2 or 6.3 as applicable.

# Chapter 7

## Visual Aids for Denoting Restricted Use Areas

### 7.1 CLOSED RUNWAY AND TAXIWAY MARKING

7.1.1 Markings denoting a closed runway should be placed at each end of the runway and along the runway at intervals of not more than 300 m.

7.1.2 Markings denoting a closed taxiway should be placed at each end of the taxiway or part of the taxiway that is closed.

7.1.3 Closed runway and taxiway markings should be painted on the surface if permanent but may be made of other materials if the closing is temporary. The marking should be in the form of an “X”, each arm of which should be at least 6 m long and 0.9 m wide as shown in Figure 7-1.

### 7.2 UNSERVICEABLE-AREA MARKING

Unserviceable portions of a manoeuvring area should be conspicuously marked with devices like cones, flags or marker boards placed at intervals that clearly mark the unserviceable area. Characteristics of unserviceable-area marking devices are:

- a) a cone should be at least 0.5 m high;
- b) a flag should be at least 0.5 m square;
- c) a marker board should be at least 0.5 m high and 0.9 m long; and
- d) the foregoing devices should be red, orange or yellow or one of these colours in combination with white.

### 7.3 MOVEMENT AREA UNSERVICEABILITY LIGHTING

Closed runways, taxiways and unserviceable areas should be marked with steady burning red lights. The runway or taxiway lights of closed portions should be turned off and, when the closed portion intersects a usable runway or taxiway, unserviceability lights should be placed at intervals of not more than 3 m across entrances to the closed area. Unserviceable area lights should be placed at intervals that will clearly delineate the unserviceable area.

### 7.4 PRE-THRESHOLD AREA

7.4.1 Where the surface leading to the runway threshold is paved but is not suitable for normal use by aircraft and exceeds 60 m in length, the entire pre-threshold should be marked with yellow chevron markings.

7.4.2 The chevrons should be formed of yellow stripes 1 m wide and should be set at an angle of 45° to the extended runway centre line (see Figure 7.1).

### 7.5 NON LOAD-BEARING SURFACE MARKING

Shoulders and other non-loading bearing surfaces that are not obvious should have the boundaries between such areas and the taxiway, holding bay or apron marked by solid white lines 15 cm wide so that the outer edge of the line indicates the edge of the load-bearing surface.



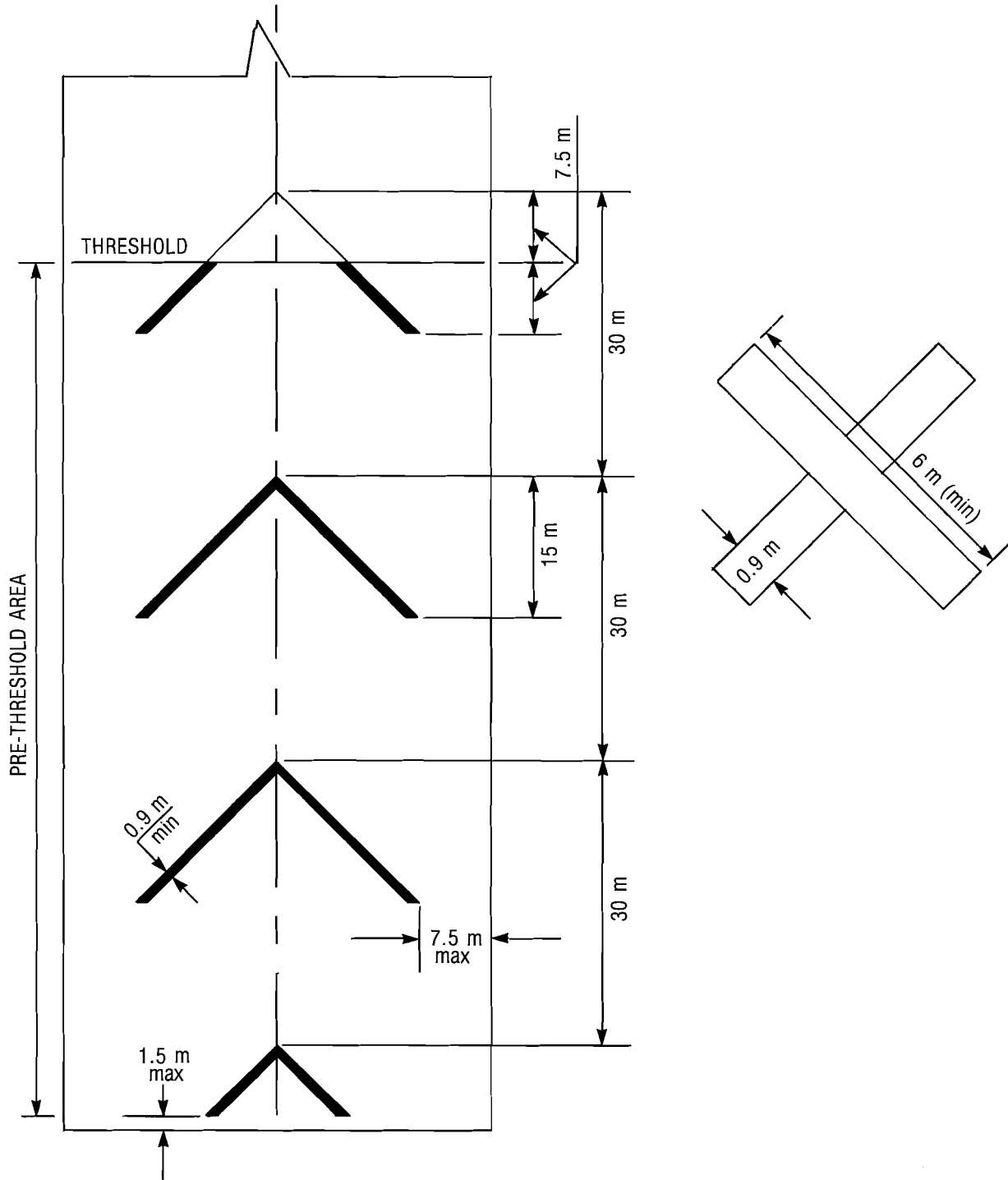

Figure 7-1. Pre-threshold area and closed runway markings

# Chapter 8

## Equipment and Installations

### 8.1 SECONDARY POWER SUPPLY

8.1.1 Secondary power should be provided by means of a standby electrical generating unit or by a second, independent public utility source. However, where the primary source of electrical power supply is sufficiently safeguarded by duplicate power feeds, a secondary power source or other suitable means, a standby power supply may not be required.

8.1.2 Switch-over from normal power to secondary power should occur automatically within 15 seconds of interruption or deterioration of the normal supply.

8.1.3 A secondary power supply should be provided, capable of supplying the power requirements of at least the stolport facilities listed below:

- a) the signalling lamp and the minimum lighting necessary to enable air traffic services personnel to carry out their duties;
- b) all obstacle lights which, in the opinion of the Appropriate Authority, are essential to ensure the safe operation of aircraft;
- c) approach, runway and taxiway lighting;
- d) meteorological equipment;
- e) essential security lighting;
- f) essential equipment and facilities for the aerodrome responding emergency agencies; and
- g) floodlighting on a designated isolated aircraft parking position if floodlighting is provided.

Annex 14, Volume I, Chapter 8, provides useful guidance on specifications for secondary power supplies including maximum switch-over times.

8.1.4 Guidance on secondary power supply is given in the *Aerodrome Design Manual*, Part 5.

### 8.2 MONITORING

A system of monitoring the visual aids should be employed to ensure lighting system reliability. Guidance on monitoring is given in the *Aerodrome Design Manual*, Part 5.

### 8.3 FENCING

8.3.1 A stolport should be fenced or otherwise protected against the entrance to the movement area of animals that would be a hazard to aircraft, and to deter the access of unauthorized persons onto a non-public area.

8.3.2 Ground installations and facilities essential to aviation safety located off a stolport should be protected against unauthorized access.

8.3.4 A fence or other means should separate the movement area and other facilities or zones on the stolport essential to safe operations from areas open to the public.

### 8.4 SITING AND CONSTRUCTION OF EQUIPMENT AND INSTALLATIONS ON OPERATIONAL AREAS

8.4.1 Unless required to be there for air navigation, no equipment or installation should be:

- a) on a runway strip, a taxiway strip or within 26 m of a taxiway other than an aircraft stand taxilane if it would endanger an aircraft; or
- b) on a clearway if it would endanger an aircraft in the air.

8.4.2 Any air navigation equipment or installation that must be located on a taxiway strip or within 26 m of a taxiway centre line should be regarded as an obstacle and should be of minimum mass and height, frangibly designed and sited to reduce hazards to a minimum. Any air navigation equipment or installation that must be located on a runway strip and which:

- a) is within 45 m of the runway centre line; or
- b) penetrates the transitional surface

should be of minimum mass and height, frangibly designed and sited to reduce hazards to a minimum. Guidance on the frangible design of navigation aids is given in the *Airport Services Manual*, Part 6.

## 8.5 STOLPORT VEHICLE OPERATION

Guidance on aerodrome vehicle operation is contained in Annex 14, Volume 1, Attachment A, Section 18.

---

# Chapter 9

## Emergency and Other Services

### 9.1 STOLPORT EMERGENCY PLANNING

9.1.1 To prepare a stolport to cope with an emergency, stolport planners should use the specifications in Annex 14, Volume I, Chapter 9, and the emergency planning guidance contained in the *Airport Services Manual*, Part 7, to develop a stolport emergency plan commensurate with aircraft operations and other activities.

9.1.2 A stolport emergency plan should provide for the actions to be taken in an emergency occurring at the stolport or in its vicinity. The plan should co-ordinate the response or participation of all agencies that could assist in responding to an emergency. There should be a procedure established for testing a stolport emergency plan with a view to improvement. Where a stolport is encompassed in a larger aerodrome the stolport emergency plan should be incorporated in the aerodrome emergency plan.

### 9.2 RESCUE AND FIRE FIGHTING

9.2.1 A stolport should be provided with appropriate rescue and fire fighting equipment services, the primary objective of which is to save lives in the event of an aircraft accident or fire at the stolport. This objective would be met by making a fire-free escape route for the evacuation or rescue of passengers and crew. A secondary objective is to protect property by containing or extinguishing fire resulting from an aircraft accident.

9.2.2 Rescue and fire fighting services should also have a standby function, coming to a high state of readiness when an in-flight emergency is declared. Stolport operators should be guided on rescue and fire fighting equipment and services by the specifications in Annex 14, Volume I, Chapter 9, and the material in Annex 14, Volume I, Attachment A, Section 17, and the *Airport Services Manual*, Part 1.

### 9.3 DISABLED AIRCRAFT REMOVAL

A stolport emergency plan should include a plan for removing a disabled aircraft that is on or adjacent to the movement area. Guidance on removal of a disabled aircraft is given in the *Airport Services Manual*, Part 5.

### 9.4 MAINTENANCE

9.4.1 A maintenance programme, including preventive maintenance should be established at a stolport to maintain facilities in a condition that does not impair safety, regularity or efficiency of air operations.

9.4.2 A maintenance programme developed in accordance with Annex 14, Volume I, Chapter 9, and using the following guidance would be suitable for a stolport.

- a) Guidance on the maintenance of shoulders is contained in Annex 14, Volume I, Attachment A, Section 8, and in the *Aerodrome Design Manual*, Part 2.
- b) Guidance on maintenance of a runway surface to preclude harmful irregularities is given in Annex 14, Volume I, Attachment A, Section 5.
- c) Guidance on evaluating the friction characteristics is given in Annex 14, Volume I, Attachment A, Section 7, and in the *Airport Services Manual*, Part 2.
- d) Guidance on assessing and expressing braking action in conditions of snow or ice is given in Annex 14, Volume I, Attachment A, Section 6.
- e) Guidance on improving braking action and on the clearing of runways is given in the *Airport Services Manual*, Part 2.
- f) Guidance on suitable chemicals for removing or preventing frost or ice on pavements is given in the *Airport Services Manual*, Part 2.

9.4.3 A system of preventive maintenance of visual aids should be employed to ensure lighting and marking system reliability. The preventive maintenance system for visual aids should ensure serviceability at any time of at least 85 per cent of:

- a) approach lights (where provided);
- b) runway threshold lights;
- c) runway edge lights;
- d) runway end lights; and
- e) stopway lights (where provided).

Continuity of guidance requires that an unserviceable light should not be permitted next to another unserviceable light.

9.4.4 The preventive maintenance system for visual aids should have the objective that, during operations in IFR conditions, all lights specified in 9.4.3 are serviceable.

Guidance on preventive maintenance of visual aids is given in the *Airport Services Manual*, Part 9.

#### **9.5 BIRD HAZARD CONTROL**

A stolport operator should institute a method of controlling birds that constitute a hazard to aircraft operations. Guidance on bird hazard control is given in the *Airport Services Manual*, Part 3.

#### **9.6 APRON MANAGEMENT SERVICE**

Where volume of traffic and operating conditions warrant, an appropriate stolport apron management service should be provided. Guidance on an apron management service is given in the *Airport Services Manual*, Part 8, and in the *Manual of Surface Movement Guidance and Control Systems* (Doc 9476).

---



# Appendix A

## Definitions

When the following terms are used in this manual they have the following meanings:

**Aerodrome.** A defined area of land or water (including any buildings, installations, and equipment) intended to be used either wholly or in part for the arrival, departure and surface movement of aircraft.

**Aeronautical ground light.** Any light specially provided as an aid to air navigation, other than a light displayed on an aircraft.

**Aeroplane reference field length.** The minimum field length required for take-off at maximum certificated take-off mass, sea level, standard atmospheric conditions, still air and zero runway slope, as shown in the appropriate aeroplane flight manual prescribed by the certificating authority or equivalent data from the aeroplane manufacturer. Field length means balanced field length for aeroplanes, if applicable, or take-off distance in other cases.

**Aircraft stand.** A designated area on an apron intended to be used for parking an aircraft.

**Apron.** A defined area, on a stolport, intended to accommodate aircraft for purposes of loading or unloading passengers, mail or cargo, fuelling, parking or maintenance.

**Balanced field length.** A field length where the distance to accelerate and stop is equal to the take-off distance of an aircraft experiencing an engine failure at the critical engine failure speed.

**Barrette.** Three or more aeronautical ground lights closely spaced in a transverse line so that, from a distance, they appear as a short bar of light.

**Bearing strength.** The structural ability of a surface to support loads imposed by aeroplanes.

**Circling procedure.** The visual manoeuvring required after completion of an instrument approach procedure.

**Clearway.** A defined rectangular area on the ground or water under the control of the appropriate authority selected or prepared as a suitable area over which an aeroplane may make a portion of its climb to a specified height.

**Displaced threshold.** A threshold not located at the extremity of a runway.

**Effective intensity.** The effective intensity of a flashing light is equal to the intensity of a fixed light of the same colour which will produce the same visual range under identical conditions of observation.

**Fixed light.** A light having constant luminous intensity when observed from a fixed point.

**Frangibility.** A characteristic of an object to retain its structural integrity and stiffness up to a desired maximum load, but on impact from a greater load, to break, distort or yield in such a manner as to present the minimum hazard to aircraft.

**Hazard beacon.** An aeronautical beacon used to designate a danger to air navigation.

**Holding bay.** A defined area where aircraft can be held, or bypassed to facilitate efficient surface movement of aircraft.

**IFR.** Instrument Flight Rules.

**Instrument runway.** One of the following types of runways intended for the operation of aircraft using instrument approach procedures:

- a) **Non-precision approach runway.** An instrument runway served by visual aids and a non-visual aid providing at least directional guidance adequate for a straight-in approach.
- b) **Precision approach runway.** An instrument runway served by a precision non-visual aid and visual aids

intended for operations down to a decision height and runway visual range appropriate to the aircraft performance and the characteristics of the stolport.

**Manoeuvring area.** That part of a stolport to be used for the take-off, landing and taxiing of aircraft, excluding aprons.

**Marking.** A symbol or group of symbols displayed on the surface of a movement area in order to convey aeronautical information.

**Movement area.** That part of a stolport to be used for the take-off, landing and taxiing of aircraft, consisting of the manoeuvring area and the apron.

**Obstacle.** All fixed (whether temporary or permanent) and mobile objects, or parts thereof, that are located on an area intended for the surface movement of aircraft, or that extend above a defined surface intended to protect aircraft in flight.

**Precision approach runway.** See Instrument runway.

**Runway.** A defined rectangular area on a stolport prepared for the landing and take-off of aeroplanes.

**Runway strip.** A defined rectangular area including the runway and stopway, if provided, intended to reduce the risk of damage to aircraft running off a runway and to protect aircraft flying over it during landing or take-off.

**Shoulder.** An area adjacent to the edge of a pavement prepared so as to provide a transition between the pavement and the adjacent surface.

**Stolport design aeroplane.** An aeroplane whose size and performance are typical of the aeroplanes a stolport is intended to serve and whose characteristics are the criteria to be applied in design of a stolport.

**Stopway.** A defined rectangular area on the ground at the end of take-off run available prepared as a suitable area in which an aircraft can be stopped in case of an abandoned take-off.

**Taxi holding position.** A designated position at which taxiing aircraft and other vehicles may be required to hold in order to provide adequate clearance from a runway.

**Taxiway.** A defined path on a stolport established for aircraft taxiing and intended to provide a link between one part of the stolport or another.

**Taxiway strip.** An area including a taxiway intended to protect an aircraft operating on the taxiway and to reduce the risk of damage to an aircraft accidentally running off the taxiway.

**Threshold.** The beginning of that portion of the runway usable for landing.

**Touchdown zone.** The portion of the runway, beyond the threshold, where it is intended landing aeroplanes first contact the runway.

**Usability factor.** The percentage of time during which the use of a runway is not restricted because of the crosswind component.

---



# Appendix B

## Aeroplane Types

Table 1 contains a list of some aeroplanes whose performance may be suitable for stolport operations. It should be noted that stolport operations may depend not only on an aeroplane's reference field length but also on its ability to achieve certain departure climb and approach angles.

TABLE 1

<i>Aeroplane designation</i>	<i>Gross take-off mass (Kg)</i>	<i>No. of pass.</i>	<i>Length (m)</i>	<i>Wing span (m)</i>	<i>Height (m)</i>	<i>Wheel base (m)</i>	<i>Gear track (m)</i>	<i>Remarks</i>
AN74	34 500	40	28.07	31.89	8.75			STOL performance
AP68TP-600	2 850	9	10.85	12.0	3.64	3.51	2.17	T.O. to 50' – 460 m Ldg from 50' – 500 m
Beech 1300	7 530	19	17.63	16.6	4.55	7.26	5.23	T.O. to 50' – 991 m Ldg from 50' – 774 m
BN2B	2 993	9	10.86	14.94	4.18	3.99	3.61	T.O. to 50' – 371 m Ldg from 50' – 299 m
CASA212-300	7 700	28	16.2	20.28	6.3	5.55	3.1	T.O. to 50' – 782 m Ldg from 50' – 519 m
CL215T	19 868	26	19.82	28.6	8.98	7.23	5.28	T.O. to 50'(Land) – 703 m Ldg from 50'(Land) – 768 m
CN235	14 400	44	21.35	25.81	8.18	6.9	3.9	T.O. to 35' – 687 m Ldg from 50' – 585 m
DH6-300	5 670	20	15.77	19.81	5.94	4.53	3.7	T.O. to 50' – 360 m Ldg from 50' – 457 m
DH7-100	19 958	50	24.54	28.35	7.98	8.38	7.16	T.O. to 50' – 688 m Ldg from 35' – 594 m
DO228-200	5 700	19	16.56	16.97	4.86	6.29	3.3	T.O. to 50' – 750 m Ldg from 50' – 620 m
HARBIN Y-12II	5 300	17	14.86	17.23	5.57	4.7	3.6	T.O. to 50' – 425 m Ldg from 50' – 500 m
LET L410UVP-E	6 400	19	14.4	19.98	5.83	3.67	3.65	T.O. to 35' – 686 m Ldg from 30' – 480 m
LET L610	14 000	40	21.42	25.6	7.6	6.6	4.59	Balanced Field – 875 m Ldg from 30' – 545 m
NAL ASUKA	38 700		33.15	30.6	10.17	9.33	4.4	QSTOL Development aeroplane.

<i>Aeroplane designation</i>	<i>Gross take-off mass (Kg)</i>	<i>No. of pass.</i>	<i>Length (m)</i>	<i>Wing span (m)</i>	<i>Height (m)</i>	<i>Wheel base (m)</i>	<i>Gear track (m)</i>	<i>Remarks</i>
PZL AN28	6 500	17	13.1	22.0	4.9	4.35	3.4	T.O. to 35' - 360 m Ldg from 50' - 315 m
SKYTRADER SCOUT	4 536	16	12.8	16.8	5.8			T.O. to 50' - 305 m Ldg run - 290 m
SKYTRADER 1400	5 896	19	14.9	16.8	5.8			T.O. to 50' - 466 m Ldg run - 165 m
STARSHIP	6 350	10	14.05	16.6	3.7	6.7	5.1	T.O. to 50' - 628 m Ldg from 50' - 963 m

# Bibliography

The DeHavilland Aircraft of Canada, Limited, Downsview, Ontario — *A Guide to STOL Transportation System Planning*. (January 1970)

Transport Canada, Air, Air Navigation Systems Requirements Branch — *Stolport Standards and Recommended Practices* TP4885E — First Edition. (May 1985)

U.S.A. Department of Transportation, Federal Aviation Administration — *Utility Airports* AC150/5300-4B

International Civil Aviation Organization — Annex 14 to the Convention on International Civil Aviation, Aerodromes, Volume I — *Aerodrome Design and Operations*, First Edition. (July 1990)

David L. Kohlman — *Introduction to V/STOL Airplanes*, Iowa State University Press/Ames (1981)

John W.R. Taylor — *Jane's All the World's Aircraft, 1988-89*, Jane's Information Group, Ltd. (1988)

— END —



© ICAO 1991  
11/91, E/P1/2000;  
8/02, E/P2/150

Order No. 9150  
Printed in ICAO