

AIR TRAFFIC SERVICES PLANNING MANUAL

FIRST (Provisional) EDITION — 1984



*Approved by the Secretary General
and published under his authority*

INTERNATIONAL CIVIL AVIATION ORGANIZATION

Published in separate English, French, Russian and Spanish editions by the International Civil Aviation Organization. All correspondence, except orders and subscriptions, should be addressed to the Secretary General.

Orders for this publication should be sent to one of the following addresses, together with the appropriate remittance (by bank draft, cheque or money order) in U.S. dollars or the currency of the country in which the order is placed.

Document Sales Unit
International Civil Aviation Organization
999 University Street
Montreal, Quebec
Canada H3C 5H7

Telephone: (514) 954-8022
Telex: 05-24513
Facsimile: (514) 954-6769
Sitatex: YULCAYA
Internet: sales_unit@icao.org

Credit card orders (American Express, MasterCard and Visa) are accepted at the above address.

Egypt. ICAO Representative, Middle East Office, Egyptian Civil Aviation Complex,
Cairo Airport Road, Heliopolis, Cairo 11776
Telephone: (20 2) 267-4840; Facsimile: (20 2) 267-4843; Sitatex: CAICAYA

France. Représentant de l'OACI, Bureau Europe et Atlantique Nord, 3 bis, villa Émile-Bergerat,
92522 Neuilly-sur-Seine (Cedex)
Téléphone: (33 1) 46 41 85 85; Télécopieur: (33 1) 46 41 85 00; Sitatex: PAREUYA

India. Oxford Book and Stationery Co., Scindia House, New Delhi 110001
or 17 Park Street, Calcutta 700016
Telephone: (91 11) 331-5896; Facsimile: (91 11) 332-2639

Japan. Japan Civil Aviation Promotion Foundation, 15-12, 1-chome, Toranomom, Minato-Ku, Tokyo
Telephone: (81 3) 3503-2686; Facsimile: (81 3) 3503-2689

Kenya. ICAO Representative, Eastern and Southern African Office, United Nations Accommodation,
P.O. Box 46294, Nairobi
Telephone: (254-2) 622-395; Facsimile: (254 2) 226-706; Sitatex: NBOCAYA

Mexico. Representante de la OACI, Oficina Norteamérica, Centroamérica y Caribe,
Masaryk No. 29-3er. piso, Col. Chapultepec Morales, México, D.F., 11570
Teléfono: (52 5) 250-3211; Facsímile: (52 5) 203-2757; Sitatex: MEXCAYA

Peru. Representante de la OACI, Oficina Sudamérica, Apartado 4127, Lima 100
Teléfono: (51 14) 302260; Facsímile: (51 14) 640393; Sitatex: LIMCAYA

Senegal. Représentant de l'OACI, Bureau Afrique occidentale et centrale, Boîte postale 2356, Dakar
Téléphone: (221) 23-47-86; Télécopieur: (221) 23-69-26; Sitatex: DKRCAYA

Spain. A.E.N.A. — Aeropuertos Españoles y Navegación Aérea, Calle Juan Ignacio Luca de Tena, 14,
Planta Tercera, Despacho 3. 11, 28027 Madrid
Teléfono: (34 1) 321-3148; Facsímile: (34 1) 321-3157

Thailand. ICAO Representative, Asia and Pacific Office, P.O. Box 11, Samyaek Ladprao,
Bangkok 10901
Telephone: (66 2) 537-8189; Facsimile: (66 2) 537-8199; Sitatex: BKKCAYA

United Kingdom. The Printing and Publications Services Limited,
37 Windsor Street, Cheltenham, Glos., GL52 2DG
Telephone: (44 1242) 235-151; Facsimile: (44 1242) 584-139

6/97

Catalogue of ICAO Publications and Audio-visual Training Aids

Issued annually, the Catalogue lists all publications and audio-visual training aids currently available.

Monthly supplements announce new publications and audio-visual training aids, amendments, supplements, reprints, etc.

Available free from the Document Sales Unit, ICAO

Air Traffic Services Planning Manual

(Doc 9426-AN/924)

FIRST (Provisional) EDITION — 1984



AMENDMENTS

The issue of amendments is announced regularly in the *ICAO Journal* and in the monthly Supplements to the *Catalogue of ICAO Publications and Audio Visual Training Aids*, which holders of this publication should consult. These amendments are available free upon request.

No.	Date	Entered by
1	15/7/85	ICAO
2	11/9/86	ICAO
3	3/11/88	ICAO
4	30/12/92	ICAO

No.	Date	Entered by

Foreword

1. INTRODUCTION

The Air Traffic Services Planning Manual (ATSPM) has been prepared by the Secretariat at the request of the Air Navigation Commission after obtaining comments of States and selected international organizations to a proposal that such a manual be developed.

2. PURPOSE AND SCOPE

2.1 The manual not only contains information which can, or should, be taken into account in the formulation of development programmes within States or regions, but also material which can, or should, be applied directly to the planning and operation of the ATS system.

2.2 To this extent, the manual consists of the guidance material previously contained in various attachments to Annex 11 — *Air Traffic Services* and the *Procedures for Air Navigation Services — Rules of the Air and Air Traffic Services* (PANS-RAC, Doc 4444), updated as necessary to reflect latest developments, and also new material concerning important aspects of ATS planning which had not been covered until now. Such new material has, for the greater part, been extracted from various sources; however, this was done only once it had been established that the material was of general interest and that its application was not limited to specific circumstances only.

2.3 The material in this manual is intended to supplement the provisions governing ATS as specified in Annexes 2 and 11 and the PANS-RAC and it should therefore be used in conjunction with these documents. As a consequence, provisions contained in these documents are not reiterated in this manual but, where found useful, have been expanded to indicate their most practical application.

3. ORGANIZATION AND CONTENTS

3.1 For convenience of reference, the manual has been divided into five basic parts, four of which deal with a specific aspect of ATS planning. The fifth part provides a useful reference for additional information. The five parts are:

- a) *Part I — Planning Factors*. This part deals primarily with matters pertaining to the concept and continued development of an ATS plan, the need for and types of ATS, their establishment and their requirements for associated facilities and services.
- b) *Part II — Methods of Application Employed by ATS*. This part deals with subjects which are of particular interest in the provision of ATS and, where appropriate, describes methods which, by experience, have been found to assist in dealing with them.
- c) *Part III — Facilities Required by ATS*. This part contains brief descriptions of the functions and the use which can be made of navigation aids as well as the requirements which facilities and equipment used by ATS should meet.
- d) *Part IV — ATS Organization, Administration and Facility Management*. This part deals with matters concerning the organization and administration of ATS in general, including personnel matters, and the management of ATS units.
- e) *Part V — Terms and References*. This part presents definitions of ATS terms and commonly used abbreviations contained within the manual. It also contains a quick reference index to facilitate locating specific subjects covered in this manual.

3.2 While much of the material in this manual has been derived from guidance material previously contained in Annex 11 and the PANS-RAC, much of the material was, however, updated in the light of the latest experience available to ICAO. New material, covering aspects which

were previously mentioned in ICAO documents, has been developed wherever it was found that a widespread need for guidance existed. In the latter case, the material in this manual is based on provisions of those States having already had a need to cover these aspects in their national documentation, on condition that experience had shown that such provisions were effective and did not cater only to a specific set of local conditions.

3.3 The material in this manual should not only be used as guidance by States in the continued development of their own national services but it should also serve as a basis for bilateral or multilateral discussions aimed at the harmonization, to the greatest extent possible, of planning activities on a regional scale, thus facilitating the development and updating of regional air navigation plans.

4. ACTION BY CONTRACTING STATES AND INTERNATIONAL ORGANIZATIONS

4.1 As it is intended that this manual should reflect, in consolidated form, the collective experience gathered over the years in the field of ATS, States and international organizations are encouraged to provide ICAO with their views, comments and suggestions regarding its contents, or its need for modification and/or extension to cover new aspects. Suggestions and recommendations should, in all cases, be made by addressing appropriate comments to the Regional Office which is accredited to the State concerned. International organizations should address their comments directly to ICAO Headquarters, Montreal.

4.2 Whenever material received from States, in accordance with the above procedure, makes it apparent that an amendment of the manual is required, such amendment will be issued by ICAO in the form most convenient for its insertion in the manual.

5. SPECIFIC REMARKS RELEVANT TO THE FIRST (PROVISIONAL) EDITION OF THE MANUAL ONLY

5.1 As indicated in 3.2, efforts have been made to use material from States in the preparation of the ATSPM whenever this appeared possible. However, in so doing, and also when determining the scope and extent of the manual, it became clear that a satisfactory solution to these questions could not be found in the relative isolation from practical needs in which, by necessity, the manual was prepared. From the beginning it was, therefore, clear that the only way to render the manual of optimum use was to prepare a provisional edition (and make it available to its potential users) in a form which would make it clear that it was not only to be reviewed in the established sense (i.e. correction, updating, expansion) but that its review should cover all aspects of its presentation, i.e. layout, content, style, depth and detail of subjects covered, usefulness in practical application and any other related aspects. Hence, the issue of this manual in the form of a provisional edition is to make this intent clear.

5.2 It is therefore in the direct interest of all States and international organizations that their review of the provisional edition of the manual be particularly thorough and that this be conducted by drawing on comments made by those for whom this manual is intended, so that the next edition, which is planned to be issued as soon as the comments received have been incorporated in it, will then, in its form as well as its content, meet States' requirements to the optimum extent.

5.3 It is intended that this first (provisional) edition of the manual be replaced by a second edition in about one or two years. States and international organizations are therefore encouraged to forward their comments as early as practicable.

Contents

	<i>Page</i>		<i>Page</i>
PART I. PLANNING FACTORS		Chapter 2. Types of Service	I-2-2-1
SECTION 1. HOW TO DEVELOP AN AIR TRAFFIC SERVICES PLAN		2.1 Introduction	I-2-2-1
Chapter 1. Factors Affecting Planning	I-1-1-1	2.2 Flight information service	I-2-2-1
1.1 Introduction	I-1-1-1	2.2.1 General	I-2-2-1
1.2 Objectives	I-1-1-2	2.2.2 Aerodrome flight information service	I-2-2-2
1.3 General considerations	I-1-1-2	2.2.3 Operational flight information service	I-2-2-2
1.4 Types of activity involved	I-1-1-3	2.2.4 Automatic terminal information service	I-2-2-2
1.5 Operational factors	I-1-1-3	2.2.5 Traffic information broadcasts by aircraft and related operating procedures	I-2-2-3
1.6 Data collection and use	I-1-1-4	2.3 Alerting service	I-2-2-3
1.6.1 General	I-1-1-4	2.4 Aerodrome control service	I-2-2-3
1.6.2 Sources of data	I-1-1-4	2.5 Approach control service	I-2-2-4
1.6.3 Forecasting methods	I-1-1-5	2.6 Area control service	I-2-2-5
1.6.4 Analysis and evaluation	I-1-1-5	2.7 Air traffic advisory service	I-2-2-6
1.7 Environmental factors	I-1-1-6	Appendix A. Flight information service combined with other services	I-2-2-8
Appendix A. Typical ATS planning organization	I-1-1-7	Appendix B. Contents of the VHF OFIS message	I-2-2-9
Chapter 2. Establishment and Maintenance of the ATS Plan	I-1-2-1	Appendix C. Contents of the HF OFIS message	I-2-2-13
2.1 Introduction	I-1-2-1	Appendix D. Contents of the ATIS message	I-2-2-15
2.2 Period covered by the plan	I-1-2-1	Appendix E. Traffic information broadcasts by aircraft and related operating procedures	I-2-2-19
2.3 Preparation and presentation	I-1-2-1	Chapter 3. Airspace Organization	I-2-3-1
2.4 Review and update	I-1-2-2	3.1 Introduction	I-2-3-1
2.5 The realities of planning	I-1-2-2	3.2 Designation and establishment of specific portions of the airspace	I-2-3-1
Appendix A. The development of an ATS plan	I-1-2-3	3.3 Airspace restrictions and reservations	I-2-3-3
SECTION 2. ESTABLISHMENT OF AIR TRAFFIC SERVICES		3.3.1 General	I-2-3-3
Chapter 1. Need for Air Traffic Services	I-2-1-1	3.3.2 Types of restriction	I-2-3-3
1.1 Introduction	I-2-1-1	3.3.3 Airspace reservations	I-2-3-4
1.2 Objectives of ATS	I-2-1-2	3.3.4 Special designated airspace	I-2-3-4
1.3 Establishment of authority	I-2-1-2	Appendix A. Illustrations of types of airspace configurations	I-2-3-5
1.4 Division of ATS	I-2-1-3		
1.5 Progressive development of ATS	I-2-1-4		

	<i>Page</i>		<i>Page</i>
Chapter 4. ATS Routes	I-2-4-1	Appendix C. The reduction of air-ground communications	I-2-8-8
4.1 Introduction	I-2-4-1	Appendix D. Presentation of detailed statements by States of new or changed ATS requirements for air-ground communication channels	I-2-8-9
4.2 Establishment of an ATS route network	I-2-4-1		
4.3 Establishment of significant points	I-2-4-3	Chapter 9. Advanced ATS Systems	I-2-9-1
4.4 Routings in terminal control areas	I-2-4-4	9.1 Introduction	I-2-9-1
Appendix A. Material relating to the establishment of standard departure and arrival routes and associated procedures	I-2-4-6	9.2 Primary surveillance radar	I-2-9-1
Chapter 5. Alignment of ATS Routes	I-2-5-1	9.3 Secondary surveillance radar	I-2-9-2
5.1 Introduction	I-2-5-1	9.4 Automation in ATC	I-2-9-3
5.2 Alignment of ATS routes based on VOR	I-2-5-2	9.5 Future developments	I-2-9-3
5.3 Alignment of ATS routes over the high seas	I-2-5-3	Chapter 10. Information From Other Sources	I-2-10-1
Appendix A. Protection values for VOR-defined ATS routes	I-2-5-4	10.1 Introduction	I-2-10-1
Appendix B. Criteria for the deployment of VOR and DME	I-2-5-7	10.2 Exchange of information with the meteorological service (MET)	I-2-10-1
Appendix C. Promulgation of nominal centre lines of VOR-defined routes	I-2-5-9	10.3 Exchange of information with the aeronautical information service (AIS) ..	I-2-10-2
Chapter 6. Area Navigation	I-2-6-1	10.4 Information from aerodrome operators	I-2-10-3
6.1 Introduction	I-2-6-1	10.5 Exchange of information with the communications services (COM) fixed and mobile communications	I-2-10-3
6.2 Use of area navigation	I-2-6-2	Appendix A. Provision of information to ATS units in respect of visual and non-visual aids	I-2-10-4
Chapter 7. Requirements for Terminal Facilities	I-2-7-1		
7.1 Introduction	I-2-7-1		
7.2 Terminal VORs and other aids	I-2-7-1		
7.3 Critical weather operations	I-2-7-1		
7.4 Surveillance of ground movements	I-2-7-3		
Chapter 8. Requirements for Communications	I-2-8-1		
8.1 Introduction	I-2-8-1		
8.2 Fixed service communications	I-2-8-1		
8.3 Air-ground communications	I-2-8-2		
8.4 Recording and retention of ATS data	I-2-8-3		
Appendix A. Basic elements for the determination of the need for ATS air-ground communication channels and their economic use	I-2-8-5		
Appendix B. Table of uniform values of designated operational range and height of VHF air-ground communication channels for specific ATS functions	I-2-8-7		
		PART II — METHODS OF APPLICATION EMPLOYED BY AIR TRAFFIC SERVICES	
		SECTION 1. AIRSPACE AND TRAFFIC MANAGEMENT	
		Chapter 1. Air Traffic Flow Management and Flow Control	II-1-1-1
		1.1 Introduction	II-1-1-1
		1.2 Air traffic management (ATM)	II-1-1-1
		1.2.1 General	II-1-1-1
		1.2.2 Air traffic services (ATS)	II-1-1-2
		1.2.3 Airspace management (ASM)	II-1-1-2
		1.2.4 Air traffic flow management (ATFM)	II-1-1-2
		1.2.5 Measures to increase ATC capacity	II-1-1-5

	<i>Page</i>		<i>Page</i>
1.3 Contingency planning	II-1-1-6	4.3 Conduct of evaluation	II-1-4-1
1.3.1 Introduction	II-1-1-6	4.4 Documentation	II-1-4-2
1.3.2 Status of contingency plans	II-1-1-6		
1.3.3 Responsibility for developing, promulgating and implementing contingency plans	II-1-1-6		
1.3.4 Preparatory action	II-1-1-7		
1.3.5 Co-ordination	II-1-1-7		
1.3.6 Development, promulgation and application of contingency plans	II-1-1-8		
Appendix A. Application of automation in air traffic flow management	II-1-1-9		
Appendix B. Examples of typical messages for the control of air traffic flow	II-1-1-11		
Appendix C. Techniques for ATC sector/position capacity estimation	II-1-1-12		
 		SECTION 2. SEPARATION	
Chapter 2. Co-ordination	II-1-2-1	Chapter 1. Determination of Separation Minima	II-2-1-1
2.1 Introduction	II-1-2-1	1.1 Introduction	II-2-1-1
2.2 Co-ordination with the military	II-1-2-1	1.2 Horizontal separation	II-2-1-2
2.3 Co-ordination with neighbouring States	II-1-2-3	1.2.1 General	II-2-1-2
2.4 Co-ordination with civil agencies and user organizations	II-1-2-4	1.2.2 Establishment of minima	II-2-1-2
Appendix A. Civil/military co-ordination of air traffic services in the United States	II-1-2-5	1.2.3 Factors to be considered in developing minima	II-2-1-3
Appendix B. Sample letter of agreement between States and ATS facilities	II-1-2-7	1.3 Vertical separation	II-2-1-4
 		1.4 Reduction of minima	II-2-1-5
Chapter 3. ATS Incident Reporting	II-1-3-1	1.5 Application of minima	II-2-1-6
3.1 Introduction	II-1-3-1	1.6 Operations on parallel runways	II-2-1-6
3.2 Reporting procedure	II-1-3-1	Appendix A. Runway separation criteria for aircraft using the same runway	II-2-1-7
3.2.1 General	II-1-3-1		
3.2.2 Reporting by pilots	II-1-3-2	 	
3.2.3 Reporting by ATS	II-1-3-2	Chapter 2. The Mach Number Technique ...	II-2-2-1
3.3 Investigation and documentation	II-1-3-2	2.1 Introduction	II-2-2-1
3.4 Analysis of ATS incidents	II-1-3-3	2.1.1 Description of the term	II-2-2-1
3.5 Release of information	II-1-3-4	2.2 Objectives	II-2-2-1
Appendix A. Air traffic incident report form	II-1-3-5	2.3 Prerequisites	II-2-2-1
 		2.3.1 Area of application	II-2-2-1
Chapter 4. ATS Evaluation	II-1-4-1	2.3.2 Aircraft instrumentation	II-2-2-1
4.1 Introduction	II-1-4-1	2.3.3 Flight progress information for ATC	II-2-2-2
4.2 Purpose and scope of evaluation	II-1-4-1	2.3.4 Adherence to assigned Mach number	II-2-2-2
		2.4 General procedures	II-2-2-2
		2.5 Specific procedures	II-2-2-2
		2.5.1 Introduction	II-2-2-2
		2.5.2 Separation at entry point when the following aircraft is the faster	II-2-2-2
		2.5.3 En-route step-climbs and step- descents	II-2-2-3
		2.5.4 Successive aircraft operating at different Mach numbers in the absence of computer-assisted conflict prediction	II-2-2-3
		Appendix A. Table — Application of Mach number technique when the following aircraft is the faster	II-2-2-4

	<i>Page</i>		<i>Page</i>
Chapter 3. Composite Separation.....	II-2-3-1	Appendix C. Estimation of occupancy values and variation of risk with occupancy.....	II-2-4-27
3.1 Introduction.....	II-2-3-1	Appendix D. Description of the radar monitoring method used by a typical ATS unit in the NAT region.....	II-2-4-31
3.2 Application of composite lateral/vertical separation.....	II-2-3-1	Appendix E. Provisions regarding follow-up action on observed and reported deviations in the NAT region.....	II-2-4-32
3.3 Implementation.....	II-2-3-3	Attachment 1 — Message format for the initial notification of operators and/or States of Registry and the Central Monitoring Agency of an observed deviation.....	II-2-4-34
Chapter 4. Minimum Navigation Performance Specifications.....	II-2-4-1	Attachment 2 — Format of written confirmation to operators of an observed deviation.....	II-2-4-35
4.1 Introduction.....	II-2-4-1	Attachment 3 — Format of covering letter to State of Registry.....	II-2-4-37
4.2 The minimum navigation performance specification.....	II-2-4-2	Attachment 4 — Format of letter to State of Registry in respect of deviations more than 25 NM but less than 50 NM occurring in NAT Region but outside MNPS airspace.....	II-2-4-38
4.3 Lateral separation minimum.....	II-2-4-2	Appendix F. Provisions regarding the reporting by pilots of the performance of INS and OMEGA equipment in the NAT region.....	II-2-4-39
4.4 Authority for establishment.....	II-2-4-2	Appendix G. Compliance with specifications of minimum navigational performance as conditions for operation in specified portions of the airspace.....	II-2-4-41
4.5 Evolution.....	II-2-4-3		
4.6 Prerequisites.....	II-2-4-4		
4.7 Derivation of criteria.....	II-2-4-4		
4.7.1 General.....	II-2-4-4		
4.7.2 Effect on risk of changes in system characteristics.....	II-2-4-5		
4.8 Assessment of the safety criteria and separation minima.....	II-2-4-6		
4.9 Application.....	II-2-4-8		
4.9.1 General.....	II-2-4-8		
4.9.2 Verification of performance.....	II-2-4-8		
4.9.3 Appraisal of operating procedures.....	II-2-4-9		
4.10 Monitoring.....	II-2-4-9		
4.10.1 General.....	II-2-4-9		
4.10.2 Monitoring procedures.....	II-2-4-9		
4.10.3 Radar monitoring process.....	II-2-4-10		
4.10.4 Practical aspects related to performance monitoring.....	II-2-4-11		
4.10.5 Without radar monitoring.....	II-2-4-12		
4.11 Operational procedures.....	II-2-4-13		
4.11.1 General.....	II-2-4-13		
4.11.2 ATC clearances.....	II-2-4-13		
4.11.3 ATC system loop errors.....	II-2-4-13		
4.11.4 Flight deck errors.....	II-2-4-13		
4.11.5 Loss of navigation capability.....	II-2-4-13		
4.12 Certification and monitoring.....	II-2-4-14		
4.12.1 Certification.....	II-2-4-14		
4.12.2 Equipment fits.....	II-2-4-15		
4.12.3 Monitoring of operators.....	II-2-4-15		
4.12.4 Central monitoring agency.....	II-2-4-15		
Appendix A. Analytical development of a minimum navigation performance specification.....	II-2-4-17		
Appendix B. Collision risk model.....	II-2-4-24		
		SECTION 3. ATS SYSTEMS DEVELOPMENT	
		Chapter 1. Airspace Sectorization.....	II-3-1-1
		1.1 Introduction.....	II-3-1-1
		1.2 Approach control.....	II-3-1-2
		1.3 Area control centre.....	II-3-1-2
		1.4 Consolidation of sectors.....	II-3-1-2
		Chapter 2. Use of Radar.....	II-3-2-1
		2.1 Introduction.....	II-3-2-1
		2.2 Primary surveillance radar.....	II-3-2-2

	<i>Page</i>		<i>Page</i>
2.3 Secondary surveillance radar	II-3-2-2	3.5.4 Integration of processed flight plan and radar data	II-3-3-10
2.3.1 General	II-3-2-2	3.5.5 MET and AIS data processing	II-3-3-11
2.3.2 The interrogator/transponder system	II-3-2-3	3.5.6 Data recording and analysis	II-3-3-11
2.3.3 Modes	II-3-2-3	3.5.7 Communications	II-3-3-12
2.3.4 Codes	II-3-2-3	3.5.8 Simulation	II-3-3-13
2.3.5 Limitations	II-3-2-4	3.6 Man-machine interface	II-3-3-13
2.3.6 Allocation and use	II-3-2-4	3.7 System reliability and availability	II-3-3-14
2.4 Precision approach radar	II-3-2-6	3.8 Data interchange	II-3-3-15
2.5 Performance of radar equipment	II-3-2-6	3.8.1 Data interchange between ATS units	II-3-3-15
2.6 Radar glide paths	II-3-2-6	3.8.2 Data interchange with other systems	II-3-3-16
2.6.1 Establishment of glide path	II-3-2-6	3.9 Further automation	II-3-3-17
2.6.2 Computation of levels	II-3-2-7	3.9.1 Extended application	II-3-3-17
2.6.3 Rates of descent	II-3-2-7	3.9.2 Technological developments	II-3-3-17
2.7 Integration of radar and non-radar services	II-3-2-8	3.9.3 Growth potential	II-3-3-18
2.8 Integration of SSR into the ATC radar system	II-3-2-9	Appendix A. Glossary	II-3-3-20
2.8.1 General	II-3-2-9	Chapter 4. ATIS Data Management	II-3-4-1
2.8.2 Integration process	II-3-2-10	4.1 Introduction	II-3-4-1
2.9 Application of radar separation	II-3-2-10	4.2 Use of flight plans	II-3-4-1
2.9.1 General	II-3-2-10	4.2.1 Submission and acceptance of flight plans	II-3-4-1
2.9.2 Reduction of minima	II-3-2-11	4.3 Repetitive flight plans	II-3-4-2
2.9.3 Use of SSR data	II-3-2-12	4.3.1 General	II-3-4-2
2.10 Separation based on computer- processed radar data	II-3-2-12	4.3.2 Basic requirements	II-3-4-2
2.10.1 Technical considerations	II-3-2-12	4.3.3 Implementation	II-3-4-2
2.10.2 Operational considerations	II-3-2-15	4.3.4 Operation	II-3-4-2
Chapter 3. Application of Automation in Air Traffic Services	II-3-3-1	4.4 Methods of ATIS message exchange	II-3-4-3
3.1 Introduction	II-3-3-1	4.5 Flight data presentation	II-3-4-4
3.2 Management considerations	II-3-3-1	4.5.1 Flight progress strips	II-3-4-4
3.2.1 Need for automation	II-3-3-1	4.5.2 Operation of the flight progress system	II-3-4-5
3.2.2 Long-term planning	II-3-3-2	Appendix A. Terms, methods and symbols used in relation to the flight progress strip marking system	II-3-4-6
3.2.3 Human factors	II-3-3-4	SECTION 4. METHODS OF APPLICATION EMPLOYED BY ATIS	
3.2.4 Controller contributions	II-3-3-4	Chapter 1. ATIS in Oceanic Airspace	II-4-1-1
3.3 ATC system considerations	II-3-3-5	1.1 Introduction	II-4-1-1
3.3.1 ATC analysis	II-3-3-5	1.2 Flight planning	II-4-1-1
3.3.2 Automation as part of a balanced system	II-3-3-5	1.3 Navigation	II-4-1-1
3.3.3 Relations to ATIS communications	II-3-3-5	1.4 Air-ground communication	II-4-1-1
3.4 Automation project considerations	II-3-3-6	1.5 Position reporting	II-4-1-1
3.4.1 System design and development	II-3-3-6	1.6 ATC clearances	II-4-1-2
3.4.2 Installation and testing	II-3-3-7		
3.5 Data processing in ATIS	II-3-3-7		
3.5.1 Applicability	II-3-3-7		
3.5.2 Flight plan data processing	II-3-3-7		
3.5.3 Radar data processing	II-3-3-9		

	<i>Page</i>		<i>Page</i>
Chapter 2. Mixed IFR/VFR Operations	II-4-2-1	Chapter 3. Wake Turbulence	II-5-3-1
2.1 Introduction	II-4-2-1	3.1 Introduction	II-5-3-1
2.2 Application of ATS	II-4-2-1	3.2 Separation minima	II-5-3-1
2.3 Provisions concerning VFR flights and related problems.	II-4-2-2	3.2.1 Application of minima	II-5-3-1
		3.2.2 Effects on aircraft.	II-5-3-2
		3.2.3 Categorization of aircraft	II-5-3-2
		3.2.4 Minima related to conditions	II-5-3-2
		3.2.5 Cautionaries	II-5-3-7
		3.2.6 Jet blast.	II-5-3-7
Chapter 3. Helicopter Operations	II-4-3-1	3.3 Minimizing the effect of wake turbulence	II-5-3-7
3.1 Introduction	II-4-3-1	3.3.1 General	II-5-3-7
3.2 Performance characteristics.	II-4-3-1	3.3.2 The ATC dilemma	II-5-3-7
3.3 ATS considerations	II-4-3-1	3.3.3 Wake turbulence characteristics.	II-5-3-7
3.4 Operations over the high seas	II-4-3-2	3.3.4 On the provision of air traffic services (ATS)	II-5-3-9
		3.3.5 On the provision of area control service.	II-5-3-9
		3.3.6 On the provision of approach control service	II-5-3-9
		3.3.7 On the provision of aerodrome control service	II-5-3-10
Chapter 4. Supersonic Transport (SST) Aircraft Operations.	II-4-4-1	3.4 Vortex sensing and tracking developments	II-5-3-11
4.1 Introduction	II-4-4-1	Appendix A. Wake vortex avoidance systems	II-5-3-12
4.2 Planning of ATS	II-4-4-1		
4.3 Communication requirements	II-4-4-2	Chapter 4. Surface Movement Guidance and Control.	II-5-4-1
4.4 Sonic boom aspects	II-4-4-2	4.1 Introduction	II-5-4-1
		4.2 Apron management service	II-5-4-1
		4.3 Surface movement radar.	II-5-4-1
		4.3.1 General.	II-5-4-1
		4.3.2 The role of SMR.	II-5-4-2
		4.3.3 Use of SMR	II-5-4-2
		4.3.4 Limitations of SMR	II-5-4-3
		4.3.5 Methods of establishing SMR identification.	II-5-4-3
		4.3.6 Relay of SMR position identification.	II-5-4-4
		4.4 Responsibilities and functions	II-5-4-4
SECTION 5. ATS ON AND IN THE VICINITY OF AERODROMES			
Chapter 1. Altimeter Setting Procedures. . . .	II-5-1-1		
1.1 Introduction	II-5-1-1		
1.2 Establishment of the transition altitude.	II-5-1-1		
1.3 Determination of the transition level.	II-5-1-2		
1.4 Determination of minimum flight levels.	II-5-1-2		
Appendix A. Method to determine the transition level which will at least coincide with the flight level corresponding to the transition altitude.	II-5-1-3		
Appendix B. Flight level graph	II-5-1-5		
Chapter 2. Category II and III Operations . .	II-5-2-1		
2.1 Introduction	II-5-2-1		
2.2 System concept	II-5-2-1		
2.3 Operational objectives.	II-5-2-1		
2.4 Ground environment	II-5-2-2		
2.4.1 Electronic guidance system.	II-5-2-2		
2.4.2 Visual aids.	II-5-2-3		
2.5 Air traffic services	II-5-2-3		
2.6 Aeronautical information service (AIS)	II-5-2-4		
2.7 Meteorology	II-5-2-4		
2.8 Ground movement control.	II-5-2-4		
		PART III — FACILITIES REQUIRED BY ATS	
		SECTION 1. GROUND BASED NAVIGATION, SURVEILLANCE AND COMMUNICATIONS EQUIPMENT	
		Chapter 1. General	III-1-1-1
		1.1 Introduction	III-1-1-1

	<i>Page</i>		<i>Page</i>
1.2 Cost-benefit considerations	III-1-1-1	Chapter 2. Specific Requirements for an	
1.3 Types of equipment associated with ATC services	III-1-1-3	Aerodrome Control Tower	III-2-2-1
Chapter 2. VOR/DME and TACAN	III-1-2-1	2.1 Operational requirements	III-2-2-1
2.1 Functional requirements	III-1-2-1	2.2 Structural requirements	III-2-2-2
2.2 Operational application	III-1-2-2	2.3 Accommodations and equipment	III-2-2-4
Chapter 3. Non-directional Radio Beacon	III-1-3-1	2.4 Other considerations	III-2-2-7
3.1 Functional requirements	III-1-3-1	Appendix A. Illustrations of aerodrome control tower designs and layouts	III-2-2-8
3.2 Operational application	III-1-3-1	Appendix B. Check-list — Aerodrome control tower and approach control operations equipment	III-2-2-16
Chapter 4. Long-range Radio Navigation		Chapter 3. Requirements for an Area	
Aids	III-1-4-1	Control Centre	III-2-3-1
4.1 Functional requirements	III-1-4-1	3.1 Operational requirements	III-2-3-1
4.1.1 General	III-1-4-1	3.2 Structural requirements	III-2-3-2
4.1.2 OMEGA	III-1-4-1	3.3 Accommodations and equipment	III-2-3-3
4.1.3 LORAN-C	III-1-4-3	Appendix A. Check-list — Area control centre operations equipment	III-2-3-5
4.2 Operational application	III-1-4-4	Chapter 4. Requirements for a Flight	
Chapter 5. Landing Systems	III-1-5-1	Information Centre	III-2-4-1
5.1 Functional requirements	III-1-5-1	4.1 Operational requirements	III-2-4-1
5.1.1 Instrument landing system	III-1-5-1	4.2 Structural requirements	III-2-4-1
5.1.2 Microwave landing system	III-1-5-2	4.3 Accommodations and equipment	III-2-4-1
5.2 Operational application	III-1-5-3	Appendix A. Check-list — Flight information centre equipment	III-2-4-3
5.2.1 Instrument landing system	III-1-5-3		
5.2.2 Microwave landing system	III-1-5-3		
Appendix A. General procedures used in the United States for the control of aircraft in ILS critical areas	III-1-5-4		
Chapter 6. VHF Direction Finder	III-1-6-1		
6.1 Functional requirements	III-1-6-1		
6.2 Operational application	III-1-6-1		
SECTION 2. FACILITIES REQUIRED BY ATS			
Chapter 1. General	III-2-1-1		
1.1 Introduction	III-2-1-1		
1.2 Operational requirements	III-2-1-1		
1.3 Structural requirements	III-2-1-1		
1.4 Accommodations	III-2-1-2		
1.5 Security measures	III-2-1-2		
		PART IV — ATS ORGANIZATION, ADMINISTRATION AND FACILITY MANAGEMENT	
		SECTION 1. ORGANIZATION AND ADMINISTRATION	
		Chapter 1. Organization of Air Traffic	
		Services	IV-1-1-1
		1.1 Introduction	IV-1-1-1
		1.2 Functions and activities	IV-1-1-1
		1.3 Management positions and duties	IV-1-1-2

	<i>Page</i>		<i>Page</i>
Appendix A. Typical civil aviation organizational chart	IV-1-1-4	Appendix B. Provisions regarding air traffic control ratings	IV-1-4-5
Appendix B. Typical ATS organizational chart	IV-1-1-5	Attachment 1. Subjects for basic knowledge questions	IV-1-4-6
Chapter 2. Personnel Requirements, Recruitment and Progression	IV-1-2-1	SECTION 2. ATS FACILITY ADMINISTRATION AND MANAGEMENT	
2.1 Determination of personnel requirements ..	IV-1-2-1	Chapter 1. Functional Management	IV-2-1-1
2.2 Recruitment	IV-1-2-2	1.1 Introduction	IV-2-1-1
2.3 Career progression	IV-1-2-2	1.2 Operational line of authority	IV-2-1-1
2.4 Supplementary considerations	IV-1-2-3	1.3 Functional organization of ATS units	IV-2-1-1
2.4.1 Additional terms of employment	IV-1-2-3	1.4 Job descriptions and responsibilities	IV-2-1-2
2.4.2 ATC's role in the civil service	IV-1-2-3	1.5 Hours of operation and duty schedules	IV-2-1-2
2.4.3 International aspects of service conditions	IV-1-2-3	1.6 Opening and closing a watch	IV-2-1-3
Appendix A. Criteria and methods used by Sweden for psychological and physiological evaluation of controllers	IV-1-2-5	1.7 Transfer of watch responsibilities	IV-2-1-3
Chapter 3. Training and Proficiency Requirements	IV-1-3-1	1.8 Air traffic services log	IV-2-1-4
3.1 Introduction	IV-1-3-1	1.9 Unit operating instructions	IV-2-1-5
3.2 Formal training	IV-1-3-1	1.10 Letters of agreement and operations letters	IV-2-1-5
3.3 On-the-job training	IV-1-3-2	1.11 Facility security	IV-2-1-6
3.4 Proficiency training	IV-1-3-3	1.12 Personnel security	IV-2-1-7
3.5 Management training	IV-1-3-4	1.13 Arrangements for visitors	IV-2-1-7
3.6 Familiarization flights	IV-1-3-5	Appendix A. General guide to good management practices	IV-2-1-8
Appendix A. Guidelines used by one State for proficiency training assessment and evaluation	IV-1-3-6	Appendix B. Job descriptions of posts in ATS	IV-2-1-9
Chapter 4. ATS Licences and Ratings	IV-1-4-1	Chapter 2. Co-ordination	IV-2-2-1
4.1 Introduction	IV-1-4-1	2.1 Introduction	IV-2-2-1
4.2 Requirement for air traffic control licences	IV-1-4-1	2.2 Co-ordination with operators, airmen and others	IV-2-2-1
4.3 Requirement for air traffic control ratings	IV-1-4-1		
4.4 Ratings for senior and supervisory personnel	IV-1-4-2	PART V — TERMS AND REFERENCES	
Appendix A. Provisions regarding air traffic controller licences	IV-1-4-3	SECTION 1. TERMS AND ABBREVIATIONS	
		Chapter 1. Glossary of Terms	V-1-1-1
		1.1 Introduction	V-1-1-1
		1.2 Air traffic service terms	V-1-1-1

	<i>Page</i>
Chapter 2. Commonly Used Abbreviations ...	V-1-2-1
2.1 Introduction	V-1-2-1
2.2 Abbreviations	V-1-2-1
 SECTION 2. REFERENCES	
Chapter 1. References and Source	
Documents	V-2-1-1
1.1 Conventions and related acts.....	V-2-1-1
1.2 Annexes to the Convention on International Civil Aviation	V-2-1-1
1.3 Procedures for air navigation services	V-2-1-1
1.4 Regional supplementary procedures	V-2-1-1
1.5 Technical publications.....	V-2-1-1

AIR TRAFFIC SERVICES PLANNING MANUAL

PART I

PLANNING FACTORS

AIR TRAFFIC SERVICES PLANNING MANUAL

PART I

SECTION 1. HOW TO DEVELOP AN AIR TRAFFIC SERVICES PLAN

SECTION 1

HOW TO DEVELOP AN AIR TRAFFIC SERVICES PLAN

Contents

	<i>Page</i>		
Chapter 1. Factors Affecting Planning	I-1-1-1	Appendix A. Typical ATS planning organization	I-1-1-7
1.1 Introduction	I-1-1-1	Chapter 2. Establishment and Maintenance of the ATS Plan	I-1-2-1
1.2 Objectives	I-1-1-2	2.1 Introduction	I-1-2-1
1.3 General considerations	I-1-1-2	2.2 Period covered by the plan	I-1-2-1
1.4 Types of activity involved	I-1-1-3	2.3 Preparation and presentation	I-1-2-1
1.5 Operational factors	I-1-1-3	2.4 Review and update	I-1-2-2
1.6 Data collection and use	I-1-1-4	2.5 The realities of planning	I-1-2-2
1.6.1 General	I-1-1-4	Appendix A. The development of an ATS plan	I-1-2-3
1.6.2 Sources of data	I-1-1-4		
1.6.3 Forecasting methods	I-1-1-5		
1.6.4 Analysis and evaluation	I-1-1-5		
1.7 Environmental factors	I-1-1-6		

Chapter 1

Factors Affecting Planning

1.1 INTRODUCTION

1.1.1 Before entering into the discussion of the factors affecting planning, and in order to avoid any possible misunderstanding, it is necessary to establish the meaning of a number of terms which will be used frequently in this manual. To this extent, it is recalled that the term "air traffic services (ATS)" has been defined in Annex 11, as being "a generic term meaning variously flight information service, alerting service, air traffic advisory service, air traffic control service, area control service, approach control service or aerodrome control service".

1.1.2 In addition, in dealing with air navigation matters, the following terms are frequently used and, for the purpose of this manual, they should be understood to have the following meaning:

a) *Assumed operating parameter.* The performance of an aircraft, which, by common agreement, can be assumed by the ground services in providing assistance to aircraft regarding their flights.

Note.- This performance relates to such factors as the broad operating characteristics of the aircraft, to their navigation or communication capability, etc., as it governs the behaviour and/or response of the aircraft to particular situations. Unless specifically stated otherwise by a pilot, it is understood that the applicable operating parameters apply to all flights.

b) *Basic operational requirement.* A need upon which agreement has been reached between the users of a given service and/or facility and its provider that it constitutes a requirement which has to be met in order for the system to perform in a satisfactory manner.

c) *Planning criteria.* The sum of principles which need to be taken into account in the planning and implementation of the air navigation system, or of its parts in order to facilitate its uniform operation in the most efficient, economic and practical manner.

d) *Method of application.* A method of operation of specific parts of the air navigation system which, by practical application has proved to be an efficient and

economic manner of operation and which, when applied on a wider scale, could ensure optimum uniformity in the operation of the air navigation system in a given area.

1.1.3 In general, planning is understood as a dynamic process which involves seeking out facts, questioning established or newly proposed methods and searching for information. It is also a continuing process which, in the interpretation of available data and in the formulation of concepts, requires vision, imagination and the courage to support and justify one's convictions. Since ATS planning is an activity which cannot be disassociated from the overall development of civil aviation, it must therefore be assumed that there is already a civil aviation infrastructure established and that the commencement or continuation of ATS planning by an administration is complementary to, and forms a part of, a national civil aviation plan. Also, ATS planning cannot be done in isolation with regard to other aspects of aviation but must take into account information concerning established commercial air route networks and existing or forecast traffic flows, the navigation aids programme, the airports development programme, the operators fleet composition and their future procurement programme and the over-all priorities of the many and varied civil aviation flying activities. It will also be necessary to give due regard to the sometimes conflicting demands of specialized military flying operations and airspace provisions for national security.

1.1.4 A plan does not become a reality overnight; therefore, early in the process of planning, consideration must be given to the various stages of implementation. The plan can then be converted to a progress chart on which every factor affecting the desired end result can be taken into account and entered in its proper order of progression. Planning involves many disciplines, for example, once the need has been justified, planning for a new control tower involves associated disciplines involving civil engineering, architectural design, electrical, mechanical and telecommunications engineering, post and telegraph systems, to mention only a few of the more important ones. To function effectively, planners must have timely advice and

access to accurate and significant information, e.g. the evaluation of advanced technology may be beyond the resources of the planners and in this case they must seek the advice of specialists or consultants.

1.1.5 Economic studies are an essential element of planning. From this source costs and benefits can be analysed and equated in monetary terms and planning budgets prepared. The ATS priorities within the total civil aviation development programme can then be established.

1.1.6 Aviation has developed at a remarkable speed and complexity when compared with the rail or maritime services. In ATS planning, local circumstances and conditions will inevitably lead to some differences in the methods, procedures and systems used between States and even between units within the same State. However, planners should resist temptations to be original unless there are very convincing arguments in favour of new approaches or change. ICAO provisions have been developed collectively by member States. Therefore, the best platform from which to commence a planning project is to use ICAO provisions and also to profit from collective work already done by other States.

1.2 OBJECTIVES

1.2.1 The art of planning is to forecast future requirements as accurately as possible, to develop alternative ways of meeting these requirements and to devise the ways and means of implementing the agreed plan to meet the objectives.

1.2.2 To do this it is necessary to clearly define the objectives. In ATS planning, objectives will include:

- a) planning the organization and management of the airspace with all the ramifications and complexities which arise from the conflicting demands of the users;
- b) investigating and recommending the best methods and technical equipment to operate the system;
- c) planning for personnel and their appropriate qualifications;
- d) functional planning and layout of the controllers' working environment and changes or additions to operational and technical buildings.

1.2.3 In order to know how to arrive at the objectives, answers to the following questions are required:

- a) What are the most reliable data sources?

- b) What are the objectives of the users, the military, the commercial sector, the private sector, the specialized operators such as gliding clubs, helicopter associations, etc.?
- c) Have the needs of all users of the airspace been fully considered?
- d) Are the objectives common to or in line with those of neighbouring States; will the respective systems be compatible so as to ensure the facilitation of international air traffic?
- e) What are the alternatives available, particularly where such alternatives could benefit resource conservation, i.e. saving money, saving manpower, saving materials?
- f) Does the plan allow for some flexibility in the application or allocation of resources?
- g) What are the consequences of delay in implementation of planning objectives?

1.2.3.1 These interests and many more of local significance must be analysed and resolved so that planners can be confident that the objectives of the plan can in fact be achieved in practice. Planners have a responsibility to the future and their planning will fall short of requirements if the objectives of the plan are ill-conceived, poorly researched or incorrectly defined.

1.3 GENERAL CONSIDERATIONS

1.3.1 Apart from specific project planning, ATS planning can form the basis for establishing many of the day-to-day requirements of the service. These include such important issues as:

- a) determining the type of airspace required for the most effective system;
- b) developing standardized working methods;
- c) identifying existing shortcomings or potential problems;
- d) developing new and improved facilities to best satisfy the ATS task;
- e) determining future personnel requirements;
- f) investigating and developing improved training techniques.

1.3.2 Sound planning will also provide policy guidance on many issues significant to the efficiency of the ATS system. Such matters include:

- a) forecasts of long-term budgets;
- b) early warning of the need for negotiation and consultation between neighbouring States' airport authorities or other interests;

- c) the determination in advance of likely environmental problems and methods of resolution;
- d) providing expert advice to associated aviation disciplines such as airport engineering services; identifying the cost/benefit advantages of providing navigation aids specifically to facilitate traffic flows;
- e) the need for improvements in taxiways, holding areas, security parking and other problems confronting controllers in the movement of aircraft on the ground.

All of these matters are pertinent to the work of planners and their role in establishing and maintaining an efficient ATS system. Finally, planners must arrange for a regular feedback on operating problems which are being encountered by ATS units so that these can be taken into account in their efforts to develop the plan along the most efficient channels.

1.3.3 Even though planning along orderly lines is essential to achieve progress in obtaining the desired objectives, the proper timing of implementation is of equal importance. It must therefore be borne in mind that overriding issues can emerge and create situations which require the immediate and urgent attention of planners even if it means departing from originally agreed proposals. Examples in this respect could include unexpected excessive traffic volumes creating unacceptable controller workload; functional environmental problems such as inadequate workspace or poor working conditions; outmoded equipment with consequential increased failure rate or prolonged outages due to unavailability of spare parts. Unless rapid corrective actions are arranged, staff morale will suffer and unit efficiency will drop.

1.4 TYPES OF ACTIVITY INVOLVED

1.4.1 *Co-ordinated policy.* This element covers the need for planning administrations to arrange for the establishment of data collection and evaluation methods, preparation of work programmes, including schedules and target dates, the establishment of co-ordination procedures with associated disciplines, arrangements for staffing programmes and the establishment of an efficient monitoring system.

1.4.2 *Physical planning.* This element includes the study of such matters as personnel environment, accommodation and technical furnishings, facility location and essential supporting services.

1.4.3 *Economic planning.* This element involves the preparation of analyses of applicable ATS data concerning aerodrome, approach and en-route traffic, both actual and forecast. From these analyses planners can determine the limitations affecting the orderly flow of traffic, study alternative methods of resolving problems encountered including detailed cost-effectiveness calculations for each proposal, and prepare economic studies for use not only in determining preferred methods but also for the benefit of associated planners.

1.4.4 *Financial planning.* This element involves the preparation of estimates and proposals for budgeting after final agreement is reached on a planning proposal.

1.5 OPERATIONAL FACTORS

1.5.1 A safe and adequate ATS system should result from sound planning techniques. All relevant operational factors must be taken into account and close meaningful co-ordination between planners and users is essential.

1.5.2 To ensure that an ATS system functions properly it must cover the following main factors:

- a) a navigation aid system which provides for both air navigation and ATS requirements;
- b) communications both point-to-point and air-ground;
- c) specialist equipment for use by ATS personnel;
- d) adequately trained and qualified controllers;
- e) provision of flight data permitting controllers to constitute a picture of the existing and expected traffic situation;
- f) provision of information on the status of air navigation facilities and services, both air and ground derived, including meteorological information.

1.5.2.1 The system must have sufficient capability and flexibility to accommodate traffic peaks and reasonable expansion possibilities to cover forecast traffic increases during a period at least equal to the lifetime of the facility. Facilities must be available for controller training and there must be a unit management structure which ensures adequate constant supervision and standardization of operating methods.

1.5.3 In ensuring that all operational factors are taken into account at the planning stage, planners will be faced with many conflicting considerations and it is in this area particularly that the judgement and experience of interested aviation activity groups can contribute to a balanced and logical proposal.

1.5.4 Operational procedures, orders or instructions arising as a result of planning must be considered in relation to the established national rules and regulations. Relevant international provisions should be used as a basis for national regulations to the maximum extent possible and differences to established ICAO provisions should only be applied when this is unavoidable.

1.5.5 At the earliest stage of planning there will invariably be the need to consider the question of compatibility with procedures adopted by adjoining States. ICAO provides the means for such negotiations by formal and informal meetings between States and in those cases where the air traffic to be handled is composed of a significant number of international operations, the expertise available within ICAO through its Regional Offices can assist in the early stages of planning.

1.5.6 Likewise within national airspace, planners will be confronted with conflicting demands from the military in particular and from the wide diversification of commercial and general aviation activities whose representatives must be given the opportunity to comment on planning proposals at an early stage of their development.

1.5.7 Poorly evaluated planning may not only affect or restrict the use of airspace but may also unduly restrict flying operations should the limitations of equipment preclude compliance with a proposed procedure.

1.5.8 Circumstances affecting the assumed operational considerations can change drastically with little or no forewarning to the planners and it is in this area that provision must be made for constant monitoring of planning forecasts vis-à-vis actual trends so that timely corrective action is taken to amend the plan accordingly.

1.6 DATA COLLECTION AND USE

1.6.1 General

The collection of meaningful and relevant statistical data is basic to sound ATS planning. Such data can be used to determine short- or long-term policy. They should include the volume and composition of traffic, split into arriving, departing and overflights, direction of flight, the levels used and types of aircraft. From the statistics thus produced, forecasts can be prepared concerning systems planning and planning of services facilities and equipment (including navigation aids).

1.6.2 Sources of data

1.6.2.1 The sources of data include:

- a) air traffic services (ATC) records from flight plans and flight progress strips, or computer print-outs where automation has been introduced into an ATS system;
- b) records of flights monitored by radar;
- c) the records of offices responsible for the collection of en-route charges;
- d) the result of studies carried out to determine methods and workload factors at ATS units;
- e) those statistical returns which are rendered to governments by airports and airlines (these would indicate airport movements of all categories of traffic and the number of hours flown by the airlines);
- f) the responses to appropriate questionnaires circulated to users.

Care should be exercised in data collection that the workload resulting from the use of complex and time-consuming methods is not beyond the realistic capacity of those expected to perform the task. Simpler methods, requiring less work may produce equally useful information and better co-operation from personnel involved.

1.6.2.2 Statistics can be a useful source in respect of the following:

- a) guidance to determine short- and long-term needs of the ATS system by:
 - 1) documenting existing conditions;
 - 2) identifying potential problem areas;
 - 3) indicating facility requirements;
 - 4) indicating personnel needs;
 - 5) providing a data base for the determination of future demands;
 - 6) providing information indicating an appropriate alternative to a plan;
- b) providing guidelines for new system design and procurement;
- c) establishing criteria for the navigation aids required to facilitate air traffic flows;
- d) providing a basis for taking remedial actions in the event that navigational guidance is inadequate for ATS purposes;
- e) as a prerequisite to studies into the reduction of separation standards and the preparation of collision risk formulas;
- f) assessment of the relationship between air traffic incidents and the volume of traffic;
- g) the provision of data to programme simulators used in ATS training.

1.6.2.3 For specified portions of an air route network which has to accommodate particularly heavy or otherwise critical traffic demands, planners should arrange, as a matter of routine, the regular collection and exchange of data and the publication of consequent analyses. These data should include information on:

- a) commercial air transport operations;
- b) military operations;
- c) other matters such as:
 - 1) the number of landing, departing and overflying flights affecting an airport, a route segment or an airspace sector;
 - 2) the vertical distribution of the traffic including an indication of the amount of traffic climbing or descending;
 - 3) the types of aircraft involved (turbo-jet, turboprop, piston).

Collection of the above data should be made during a predetermined representative time span (seven days) in the high and low density travel seasons. Once the task has been undertaken it must be repeated regularly in order to assess the growth or decline in activity.

1.6.2.4 It should be mentioned that, for some statistical purposes, the *Manual on the ICAO Statistics Programme* (Doc 9060) may be a useful source of information especially as regards financial statistics for route facilities and services, en-route traffic movement statistics and aerodrome traffic statistics. Valuable statistical data concerning international air traffic can also be obtained from the International Air Transport Association (IATA). However, material from these sources is no substitute for detailed national data obtained directly from operational sources.

1.6.3 Forecasting methods

The method of forecasting will depend on the data available. Where an ATS system has been in operation for several years, historical data may be available which will indicate trends and growth areas and should supplement current data. Forecasts should be expressed in terms commonly used by those concerned with the planning of air navigation systems and should indicate likely seasonal, weekly or daily changes in the future traffic demand. Factors affecting the accuracy of forecasting include:

- a) the availability of an adequate data base;
- b) the use of proven forecasting methods, e.g. extrapolation or trend analysis;

- c) introduction of factors not previously considered such as changes in airspace requirements or alterations to routes;
- d) the influence of factors which are difficult to quantify — changes in government policy regarding civil aviation, re-orientation of traffic flows due to changing customer habits especially in respect of holiday areas, airline operation costs, fuel economies or the introduction of new aircraft types.

Particularly in the case of c) and d) above, the preparation of differing sets of assumptions will assist planners in building up alternative pictures of the economic, social, technological and commercial considerations and assist in identifying and quantifying future traffic probabilities. Poor interpretation of data can distort the accuracy of forecasts which in turn may lead to inadequate provision for the future.

1.6.4 Analysis and evaluation

1.6.4.1 It is necessary to identify the information required under specific headings, and in peak values by the analysis of instantaneous traffic, movements per clock hour and movements per day as follows:

- a) total traffic movements, including:
 - 1) outbound flights;
 - 2) inbound flights;
 - 3) overflights;
 - 4) crossing flights;
 - 5) direction of flights;
- b) flight level distribution according to performance category (turbo-jet, turboprop, piston);
- c) category of flight:
 - 1) commercial;
 - 2) military;
 - 3) other.

1.6.4.2 Emphasis should be placed on presenting data in a comprehensive manner, preferably in graph form for easy comparison. When the analysis of the total traffic is prepared, the figures for the “average day” are obtained by adding the total number of movements for each day according to each route and dividing the sum by the number of days in the data collection period. Traffic figures for the “busy day” are obtained by selecting for each of the routes the highest figure recorded during the collection period. This figure, together with the relative day of the week on which the figure was recorded, will constitute the “busy day”.

1.6.4.3 Traffic figures for the "busy hour" are obtained by selecting for each of the routes the highest traffic figure recorded in one clock hour during the "busy day". This figure, together with an indication of the hour within which it was recorded, will constitute the "busy hour" figure. The determination of the "busy day" and the "busy hour" value should also include a breakdown of the types of aircraft on the route during these periods and the operationally preferred height bands.

1.6.4.4 Considerable work has been carried out by the North Atlantic and European traffic forecasting groups in the field of providing forecasts for systems planning and more detailed information on this may be obtained upon request to any Regional Office of ICAO.

1.7 ENVIRONMENTAL FACTORS

1.7.1 Environmental considerations require special study at an early stage in ATS procedural planning, particularly in respect of the effect of aircraft noise and possible atmospheric pollution onto the area exposed to these phenomena.

1.7.2 Environmental control is an essential element of aerodrome planning and the ATS planning policies should be co-ordinated within the over-all aerodrome planning framework. The most significant problems arise in the arrival and departure/climb-out areas and, to the extent that a choice is available, decisions regarding the alignment of runways can be of great significance to future traffic management. Departure clearances calling for evasive flight manoeuvres in the interests of noise abatement can present many problems for the pilot and the controller.

1.7.3 Studies on the noise impact generated beneath an aerodrome circuit can necessitate non-standard patterns and acrobatic, low-flying and training areas require particular study. Where possible, procedures should be designed to avoid flying closer than 600 m (2 000 ft) vertically over hospitals, educational institutions and similar noise-sensitive activities, e.g. zoological gardens. Pollution from jet efflux can cause discomfort to homeowners and could damage valuable crops. Consideration need also be given to fuel dumping areas in case aircraft are required to return to their departure point shortly after take off.

1.7.4 Studies on the environmental impact generated beneath a proposed flight path should be simulated by exercises to establish their acceptability. The responsibility rests with the planners to recognize a potential problem area and discuss it with the appropriate authority. An environmental impact report should be prepared so that every party concerned can understand and comment on the problem from their own viewpoint. In the event that a planning proposal is unfavourably received, planners have a responsibility to endeavour to establish alternative routing or other alleviating proposals, bearing in mind the overriding need for safety of flight operations.

1.7.5 Final decisions regarding environmental aspects do not rest with the ATS planners, therefore it is essential that the information provided to the appropriate authorities for the purpose of studies and decision is both detailed and accurate. Information based on incomplete data could result in unnecessarily restrictive decisions which in turn could limit the capability of ATS to efficiently manage traffic.

1.7.6 More detailed information on land use and environmental control concerning an aerodrome and its environs, is contained in the *Airport Planning Manual* (Doc 9184, Part 2).

— — — — —

Appendix A

Typical ATS Planning Organization

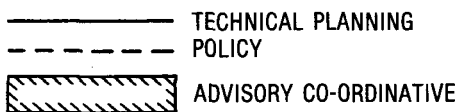
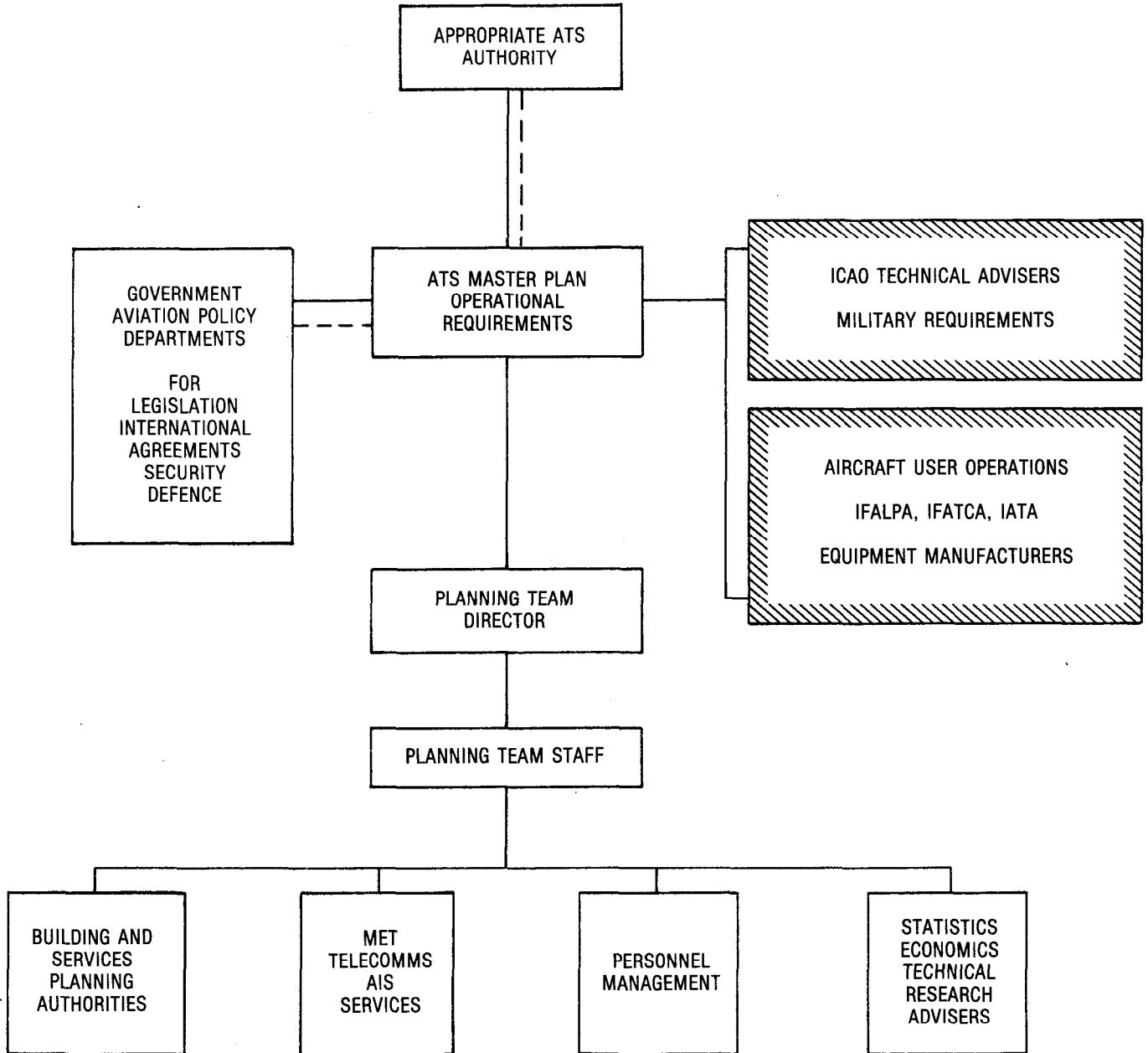

Chapter 2

Establishment and Maintenance of the ATS plan

2.1 INTRODUCTION

Air traffic services (ATS) planning covers both short-term and long-term requirements and may be necessary for technical facilities, personnel and training requirements, or to provide for unforeseen or temporary circumstances. In all cases it is necessary to develop a framework within which the problem can be analysed and solutions formulated to assist in the decision-making process. Processes involved in the development of an ATS plan are illustrated in Appendix A.

2.2 PERIOD COVERED BY THE PLAN

2.2.1 Planners should expect that there will be a delay between the approval of a plan and its implementation. The time may vary from several months for the introduction of new airspace procedures, to many years for the introduction of new technology or facilities. As any plan is based on forecasts, studies and reports, it will become apparent that planning is heavily reliant on the accuracy and reliability of such source information. Misinformation and poor planning can be reflected in the economics of air operations, through the provision of inadequate equipment and insufficient trained personnel to operate and maintain a system. In view of the likely timespan between initial planning and implementation, methods must be introduced to ensure the plan remains current and up to date. This requires a constant review of current data, simulation of the project objectives in the light of new developments and frequent study of comments from user groups.

2.2.2 Long-term planning demands that ATS requirements be forecast five or even ten years ahead of time. The implementation of the plan is likely to take place in stages which, whilst they may be affected by factors such as finance or equipment or personnel availability, should primarily be established so as to ensure the continued safe and expeditious handling of air traffic and to avoid

increasingly costly delays or system limitations. The advantage of formulating a long-term plan with a staged implementation is that it provides planners with the opportunity to review the plan in the light of developments before finalizing the details of each successive stage.

2.3 PREPARATION AND PRESENTATION

2.3.1 After having obtained and evaluated the best forecasts from all relevant sources, it will then be possible to prepare alternative proposals for the solution of specific problems in the form of a plan. In preparing alternatives it is essential to record explicitly and clearly the data source and the forecasting techniques used so that all parties concerned with the execution of the plan can conduct their individual studies. Assumptions or personal judgements injected into the planning must be explained and the logic defended. The presentation of a plan as a working document is a significant step in the planning process and can assume a major role in its ultimate acceptance, deferral or cancellation. Appropriate format and a clear and concise style can contribute significantly to its presentation. The body of the presentation must contain the maximum descriptive detail of the need for the plan and its proposed implementation. Changes to established methods, systems or technology must be justified by sound arguments; advantages of proposed change can best be illustrated by examples of their successful application by other States. In addition, pictorial presentation is important, particularly where planning involves facility changes and, whenever possible, photographic or sketch illustrations should be used to amplify text descriptions. Whilst statistics and graphical diagrams may be necessary, they are generally of lesser impact and should therefore be presented in the form of appendices rather than be included in the main text of the plan.

2.3.2 The preparation and presentation of a plan is incomplete unless it reaches clear conclusions, states

recommendations and proposes an implementation programme. The presentation should therefore be arranged in the following sequence:

- a) definition of the objectives;
- b) detailed explanation of the research methods used;
- c) explanation of the proposals, including alternative solutions;
- d) description of advantages and disadvantages of each proposal made;
- e) assessment of cost-effective factors and priorities;
- f) conclusions reached and recommendations made;
- g) proposals for an implementation programme with realistic target dates.

2.4 REVIEW AND UPDATE

2.4.1 In all planning activities a time will arise when circumstances indicate the need for review and probably an updating of the plan. At this stage the inaccuracies of the original planning forecasts should have become evident and those parts of the plan in need of review can therefore be more easily identified. Without abandoning forecasts, planners should arrange follow-up communications with user groups and establish planning exercises which actively encourage their critical but constructive contributions. Based on the outcome of these reviews, alternatives may be examined or simulated or live trials may be staged and decisions taken to change or update the original concept.

2.4.2 The updating process itself follows, to some extent, the methods used in the original planning, in that the same checks and balances of personnel involvement, financial considerations, resource availability and over-all work priorities within an administration will apply.

2.4.3 In addition to reviewing forecasts, planners should carry out studies to ensure that any updating of the plan is

based on current operational requirements. This periodic review should be incorporated into the planning programme from the outset. Planners should be alert to economic, environmental, financial and operational changes as they occur, not only in ATS, but also in the aviation industry as a whole so that they develop a sense of timing and anticipation which enables them to remain ahead of current developments.

2.5 THE REALITIES OF PLANNING

2.5.1 The variations of air transport affecting the air route networks, the introduction of advanced technology, the changes in operators fleet composition, taxes, as well as the capacity of established systems make the need for sound planning more urgent. Such variables, however, interact with and affect the accuracy of forecasts and make the planning task more formidable. As previously stated, inadequate, inaccurate or unco-ordinated planning can result in misuse of personnel and material resources thus placing a heavy responsibility on planners to strive for accuracy, and ensure that only relevant and accurate data are used and anything which cannot be fully relied upon is discarded.

2.5.2 ATS planning cannot be done as an isolated activity; it involves everyone contributing to or using the ATS system. Planning is the function of gathering, assembling and disseminating the collective knowledge of many experts in such a way that there is a programmed advancement of the art and practice of ATS. This planning manual is intended to assist operational and technical personnel to appreciate the fact that planning develops objectives, which in turn lead to guidelines which develop into a planning exercise, followed by decisions and finally implementation and thus ensures the safe, orderly and expeditious movement of both national and international aircraft.

Appendix A

The Development of an ATS Plan

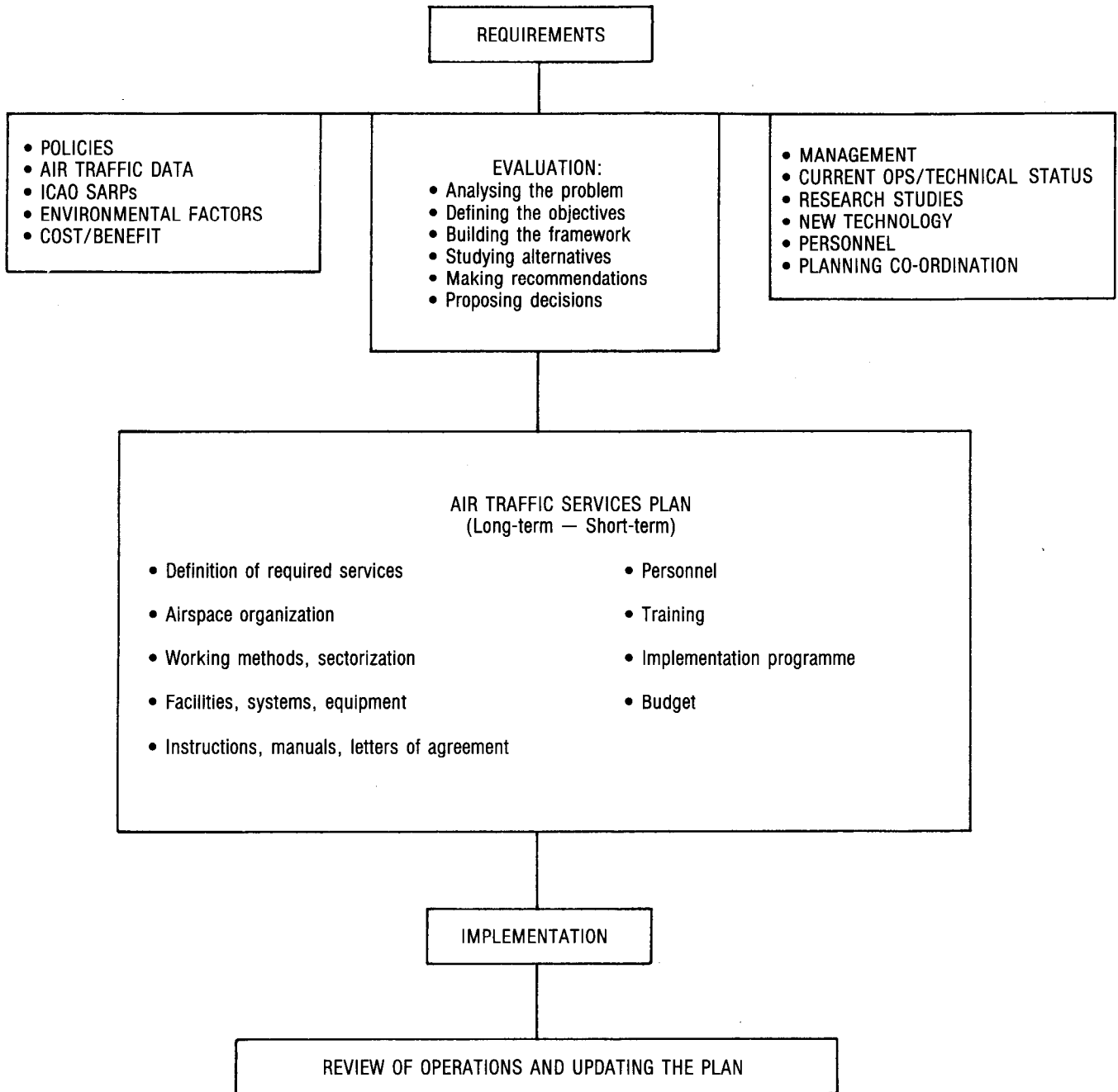

AIR TRAFFIC SERVICES PLANNING MANUAL

PART I

SECTION 2. ESTABLISHMENT OF AIR TRAFFIC SERVICES

SECTION 2

ESTABLISHMENT OF AIR TRAFFIC SERVICES

Contents

	<i>Page</i>		<i>Page</i>
Chapter 1. Need for Air Traffic Services ..	I-2-1-1	Chapter 3. Airspace Organization	I-2-3-1
1.1 Introduction	I-2-1-1	3.1 Introduction	I-2-3-1
1.2 Objectives of ATS	I-2-1-2	3.2 Designation and establishment of specific portions of the airspace	I-2-3-1
1.3 Establishment of authority	I-2-1-2	3.3 Airspace restrictions and reservations ..	I-2-3-3
1.4 Division of ATS	I-2-1-3	3.3.1 General	I-2-3-3
1.5 Progressive development of ATS	I-2-1-4	3.3.2 Types of restriction	I-2-3-3
Chapter 2. Types of Service	I-2-2-1	3.3.3 Airspace reservations	I-2-3-4
2.1 Introduction	I-2-2-1	3.3.4 Special designated airspace	I-2-3-4
2.2 Flight information service	I-2-2-1	Appendix A. Illustrations of types of airspace configurations	I-2-3-5
2.2.1 General	I-2-2-1	Chapter 4. ATS Routes	I-2-4-1
2.2.2 Aerodrome Flight Information Service	I-2-2-2	4.1 Introduction	I-1-4-1
2.2.3 Operational Flight Information Service	I-2-2-2	4.2 Establishment of an ATS route network	I-2-4-1
2.2.4 Automatic Terminal Information Service	I-2-2-2	4.3 Establishment of significant points....	I-1-4-3
2.2.5 Traffic information broadcasts by aircraft and related operating procedures	I-2-2-3	4.4 Routings in terminal control areas	I-2-4-4
2.3 Alerting service	I-2-2-3	Appendix A. Material relating to the establishment of standard departure and arrival routes and associated procedures	I-2-4-6
2.4 Aerodrome control service	I-2-2-3	Chapter 5. Alignment of ATS Routes	I-2-5-1
2.5 Approach control service	I-2-2-4	5.1 Introduction	I-2-5-1
2.6 Area control service	I-2-2-5	5.2 Alignment of ATS routes based on VOR	I-2-5-2
2.7 Air traffic advisory service	I-2-2-6	5.3 Alignment of ATS routes over the high seas	I-2-5-3
Appendix A. Flight information service combined with other services	I-2-2-8	Appendix A. Protection values for VOR-defined ATS routes	I-2-5-4
Appendix B. Contents of the VHF OFIS message	I-2-2-9	Appendix B. Criteria for the deployment of VOR and DME	I-2-5-7
Appendix C. Contents of the HF OFIS message	I-2-2-13	Appendix C. Promulgation of nominal centre lines of VOR-defined routes	I-2-5-9
Appendix D. Contents of the ATIS message	I-2-2-15		
Appendix E. Traffic information broadcasts by aircraft and related operating procedures	I-2-2-19		

	<i>Page</i>		<i>Page</i>
Chapter 6. Area Navigation	I-2-6-1	Appendix D. Presentation of detailed statements by States of new or changed ATS requirements for air-ground communication channels	I-2-8-9
6.1 Introduction	I-2-6-1		
6.2 Use of area navigation	I-2-6-2		
Chapter 7. Requirements for Terminal Facilities	I-2-7-1	Chapter 9. Advanced ATS Systems	I-2-9-1
7.1 Introduction	I-2-7-1	9.1 Introduction	I-2-9-1
7.2 Terminal VORs and other aids	I-1-7-1	9.2 Primary surveillance radar	I-2-9-1
7.3 Critical weather operations	I-2-7-1	9.3 Secondary surveillance radar	I-2-9-2
7.4 Surveillance of ground movements	I-2-7-3	9.4 Automation in ATC	I-2-9-3
		9.5 Future developments	I-2-9-5
Chapter 8. Requirements for Communications	I-2-8-1	Chapter 10. Information From Other Sources	I-2-10-1
8.1 Introduction	I-2-8-1	10.1 Introduction	I-2-10-1
8.2 Fixed service communications	I-2-8-1	10.2 Exchange of information with the meteorological service (MET)	I-2-10-1
8.3 Air-ground communications	I-2-8-2	10.3 Exchange of information with the aeronautical information service (AIS)	I-2-10-2
8.4 Recording and retention of ATS data	I-2-8-3	10.4 Information from aerodrome operators	I-2-10-3
Appendix A. Basic elements for the determination of the need for ATS air-ground communication channels and their economic use	I-2-8-5	10.5 Exchange of information with the communications services (COM) — fixed and mobile communications ..	I-2-10-3
Appendix B. Table of uniform values of designated operational range and height of VHF air-ground communication channels for specific ATS functions	I-2-8-7	Appendix A. Provision of information to ATS units in respect of visual and non-visual aids	I-2-10-4
Appendix C. The reduction of air-ground communications	I-2-8-8		

Chapter 1

Need for Air Traffic Services

1.1 INTRODUCTION

1.1.1 As for any other form of transportation, there is an inherent need to provide certain services to air traffic so that it can be conducted in a safe and orderly manner. There are, however, two aspects of air traffic which impose specific requirements on these services and these are:

- a) the fact that, once air traffic is under way, it cannot be held en route for prolonged periods of time and can only be brought to a halt by a landing;
- b) the world-wide scope of aviation activities is dictated more by considerations of an international character than any other form of transport.

1.1.2 In addition, air transport, and more particularly that conducted at the international level, has now assumed such a role in the economic development of our civilization that its disturbance generally results in consequences which are not restricted only to the area where they occur, but can also have repercussions which extend far beyond that area.

1.1.3 The planning for and the execution of air traffic services (ATS) is essentially a national responsibility unless agreements have been concluded amongst States to conduct this planning as a joint effort for a defined area covering more than one State, or for areas where no sovereign rights are exercised (e.g. the high seas). It is, therefore, of prime importance that both the planning and execution of ATS be done so that optimum uniformity is maintained to the largest possible extent. While this objective is normally pursued by ICAO through its efforts in world-wide standardization and in regional planning of air navigation services, it should, for the reasons given, be supplemented by bilateral or multilateral co-ordination among States. This bilateral or multilateral co-ordination should cover those generally more detailed aspects which have not been covered by the efforts made within the framework of ICAO.

1.1.4 In many States, the military services constitute a rather important part of the airspace users. In some States, military authorities have therefore established their own

ATS in parallel with the civil ATS system in order to provide for their specialized operations (e.g. fighter training, interceptions, low-level missions, special air exercises, etc.) as well as for those flight operations which are conducted in a manner similar to those of civil users (e.g. air transport, liaison and navigation training flights). The co-existence of a civil as well as a military ATS has, in many cases, resulted in competition and an inefficient use of the airspace. For this reason, in a number of States where these problems became particularly acute, it was decided to create an integrated ATS system to provide for both the civil and military needs. Experience gained by these States seems to indicate that this solution offers promising results regarding the equitable and efficient sharing of the airspace and avoids many of the problems created by the co-existence of two competing services.

1.1.5 The cost-effectiveness aspect of ATS, which has become much more important since user charges have been established by a large number of States, is a further consideration to be taken into account in determining the need for ATS. It has been found that not everything that is desirable is also necessary and that a balance must therefore be reached between the requirements put forward for the improvement of the ground services and the cost involved in putting them into effect. In establishing the needs for ATS, their users should therefore be given an opportunity during the planning stage to express their views and these views should receive due consideration.

1.1.6 Furthermore, the close interrelationship between national services of adjacent States, as mentioned above, makes it necessary that, once a basic air traffic service has been established, its development and improvement should be pursued in close co-ordination with affected adjacent States. Isolated action, especially as far as en-route services are concerned, will frequently deprive the State concerned from achieving the expected results if other affected national services do not follow with consequential and timely improvements of their services. As a consequence, situations may arise where States will be required to improve their services, not because there is an urgent national requirement to do so, but in order to ensure that

other, more or less adjacent States, being confronted with such needs, are not deprived of the benefits of their efforts.

1.1.7 In summary, it would appear that the need for ATS at and in the vicinity of specific aerodromes can, to a large extent, be determined on a local or national level and in consultation with operators concerned up to the point when these services will have consequences on the en-route flow of air traffic over a wider area. The need for ATS en-route traffic will, however, in the majority of all cases require the closest possible co-ordination amongst all those participating in the provision of such services over a wide area (generally an ICAO region).

1.2 OBJECTIVES OF ATS

1.2.1 The objectives of the ATS as specified in Annex 11, 2.2 are briefly:

- a) to prevent collisions between aircraft and between aircraft on the ground and obstructions;
- b) to maintain an orderly and expeditious flow of air traffic;
- c) to provide aircraft with advice and information required for the safe and efficient conduct of flights;
- d) to notify those involved in search and rescue of aircraft in need of this service and assist them in this task.

1.2.2 From these objectives, it follows that the emphasis of the ATS is placed on the word "service". This emphasis means that ATS should, to the optimum extent, be at the disposition of its users and that any action on its part which is likely to interfere with the intention of any of its individual users, will only be justified if the results in improved services apply to the majority of users of the services there. In no case should it be permissible for ATS to take action affecting its users which is motivated by the convenience of ATS only.

1.2.3 In addition, since ATS is normally the only ground service which is in direct contact with aircraft in flight, care must be taken in assigning additional responsibilities emanating from other national requirements to ATS (i.e. diplomatic authorization to operate over the territory of a State), operational supervision of flights, etc. (i.e. national security), so as not to dilute the service provisions of ATS to a point where it will become difficult for controllers to draw a clear line in distinguishing the different capacities in which they are expected to act. In general, experience seems to indicate that the less additional responsibilities that are given to ATS the better it is able to meet its primary objectives.

1.2.4 Similar considerations apply with respect to the provision of information by ATS to aircraft not directly derived from the activities of ATS (e.g. information on the status of other than ATS facilities and services, meteorological information, etc.). Such information should be provided to ATS for onward transmission in a manner and form which requires the least amount of interpretation and/or responsibility for the accuracy and timeliness of the information in question.

1.3 ESTABLISHMENT OF AUTHORITY

1.3.1 While the ICAO Convention specifically recognizes the sovereignty of each State within the airspace over its territory, ICAO also recognizes that the provision of air navigation services should primarily be dictated by operational considerations inherent in air navigation. Therefore, while in most cases the provision of ATS by a State will be confined to the airspace over its territory, there are nevertheless numerous cases, especially in areas where the political configuration was well established before aviation became a significant factor in world developments, where the political boundaries do not lend themselves as evident operational dividing lines between the areas of responsibility of adjacent national ATS services.

1.3.2 For this reason, Annex 11, 2.1, makes specific provisions for arrangements whereby adjacent States are encouraged to conclude mutual agreements which allow for the delegation of responsibility for the provision of ATS from one State to another, on the understanding that this will in no way affect the question of sovereignty over the airspace so delegated.

1.3.3 As regards the provision of services over the high seas or other areas where no sovereign rights are exercised (i.e. Antarctica), ICAO has envisaged that ATS services shall be established in accordance with regional air navigation agreements whereby the totality of interested States in a particular region entrust a State, or a selected number of States, with the provision of air navigation services and more especially ATS, in a specified portion of such airspace (typical examples are those in the North Atlantic (NAT) and the Pacific (PAC) regions). In this respect it should be noted that the assumption of such delegated responsibility by a State, by virtue of a regional air navigation agreement, does not imply that this State is then entitled to impose its specific rules and provisions in such airspace at its own discretion. In fact, conditions of operation therein will be governed by applicable ICAO provisions of a world-wide and supplementary regional nature

and specific national provisions may only be applied to the extent that these are essential to permit the State the efficient discharge of the responsibilities it has assumed under the terms of the regional air navigation agreement.

1.3.4 A further problem which concerns ATS over the high seas has recently come to light in relation to oil exploration activities in the sea bed. In a number of cases, the division of oil exploration areas among States, bordering on the sea bed in question, bears no relationship to the airspace division made for the same area. Therefore, while this airspace division may be found satisfactory to cater for the needs of en-route operations by aeroplanes, it generally does not cover the case of helicopter (and aeroplane) operations conducted specifically in support of the oil exploration activities. Experience already gained in some complex cases (e.g. the North Sea and the Gulf of Mexico) indicates that the solution to these specific problems should not be sought so much by re-organizing the airspace in question, but rather by concluding special arrangements between States concerned, following appropriate consultation with operators, covering the delegation of responsibility for the provision of specific services in accordance with the operational needs and relevant cost-effectiveness considerations, both for the ground services and for the operators concerned. An example for such arrangements is the agreement concluded between Norway and the United Kingdom covering North Sea helicopter operations. If desired, copies of their latest agreement may be obtained on request to any ICAO regional office.

1.3.5 Experience seems to show that the establishment of an ATS authority on a national level should best be done so that it can operate with an optimum of flexibility, both on the internal level and with adjacent ATS authorities. Flexibility is essential if ATS authorities are to be able to keep pace with the dynamic development of air navigation and respond to resulting new operational requirements in an efficient and timely manner. In practice, this would imply that, while national ATS authorities will obviously be required to operate within the legal, administrative and budgetary confines applicable to all national administrations, they should be given optimum autonomy as regards their handling of operational and technical matters without being excessively inhibited in their activities by non-technical supervisory agencies.

1.4 DIVISION OF ATS

1.4.1 In accordance with Annex 11, 2.3, the air traffic services are sub-divided into the following three services;

air traffic control (ATC) service, flight information service (FIS) and alerting service. It should, however, be clearly understood that the provision of alerting service is not an isolated function but is rather incorporated in the provision of flight information and/or ATC service. The same condition applies for the provision of flight information service whenever an ATC service has been established, except in those cases where, due to traffic density and workload considerations, flight information service may be provided by personnel specifically designated for this task.

1.4.2 The ATC service is sub-divided into three parts, depending on the stage of flight to which it is applied. At and in the vicinity of aerodromes, ATC is normally provided by the aerodrome control service, which operates from a control tower, hence its abbreviation (TWR) aerodrome control tower. Approach control service (APP) is also provided in the vicinity of aerodromes, but is a service which is mainly concerned with flights operating on an instrument flight rules (IFR) flight plan and in instrument meteorological conditions (IMC). Area control service (ACC) is that part of the ATC service which is provided to controlled flights while they are en route and is normally done from an ACC.

1.4.3 The division of responsibilities between TWR and APP and between APP and ACC cannot be rigidly defined because the responsibilities depend very much on local conditions which vary from location to location. They must therefore be determined in each case and with due regard to traffic conditions, its composition, the airspace arrangements, prevailing meteorological conditions and relative workload factors. However, arrangements governing the division of responsibilities between these different parts of the ATS service, should not result in increased requirements for co-ordination and/or an undesirable inflexibility in the use of airspace, nor in an increased workload for pilots because of unnecessary transfers of control and associated radiocommunication contacts.

1.4.4 It should also be noted that, depending on traffic conditions, the provision of certain parts of the ATC service may be restricted to those times or periods when the service in question is actually required and that, outside these times or periods a more limited type of service (e.g. in the case of an APP, only aerodrome control or aerodrome flight information service (AFIS)) may be provided. Resorting to such arrangements presupposes, however, that this will, under no circumstances, result in a decrease of flight safety, or result in other consequences having an unduly detrimental effect upon flight operations conducted under these conditions.

1.4.5 The division of responsibilities between APP and ACC requires particularly careful consideration because it can have a significant effect on the capacity of the ATC system at the location concerned, especially as regards the requirement for co-ordination and the workload imposed on both controllers and pilots. It has, for instance, been found that at some rather busy major aerodromes, the arrangement whereby departing traffic is transferred directly from the aerodrome control tower to a departure control position in the associated ACC, or only that part of arriving traffic which has been brought into a position where it no longer constitutes traffic to other departing or overflying traffic is released to APP by the associated ACC, has contributed to an optimum flow of considerable amounts of air traffic while keeping the workload within manageable proportions. It should, however, be noted that such arrangements depend specifically on the local situation and that they should only be applied after careful consideration of all relevant factors by all parties concerned.

1.4.6 In numerous cases it has also been found that arrangements between APP and ACC, which leave the transfer of control of departing as well as arriving traffic between them to *ad hoc* agreements made in the light of the over-all traffic situation, have worked well whenever the will on both sides to obtain results has prevailed over the thinking in pure categories of competence.

1.5 PROGRESSIVE DEVELOPMENT OF ATS

1.5.1 From the above, it follows that, initially, the simplest form of providing ATS is to establish a flight information centre (FIC), covering a given area, which provides flight information and alerting service to en-route traffic; see Chapter 2, 2.2 below regarding flight information regions (FIRs). At the same time, at those aerodromes where air traffic tends to concentrate, it would then be appropriate to establish an AFIS which, in addition to alerting service and normal FIS, will provide aircraft with detailed information regarding other traffic operating in the vicinity of the aerodrome in question, so as to permit the pilots to arrange their flights so that a safe and expeditious flow of air traffic results.

1.5.2 In most cases, fairly early in the development of traffic at specific aerodromes, the point will be reached where the responsibility for the arrangement of such a safe and expeditious flow of traffic can no longer be left to the discretion of individual pilots. This case applies particularly when IFR operations of a commercial nature are

conducted at such an aerodrome. However, experience has also shown that, if the traffic at a specific aerodrome is composed largely of pilots who are thoroughly familiar with the local conditions and their operations consist primarily of visual flight rules (VFR) flights, the decision to establish an aerodrome control may not need to be taken as early as would otherwise be needed.

1.5.3 The establishment of an aerodrome control service does not necessarily imply the immediate provision of a special ATC facility (control tower) but it is rather intended to mean that the service will be provided by adequately qualified ATC personnel, having means and facilities at their disposal appropriate for the given situation. These means and facilities can range from relatively simple arrangements to a complete system of ATC services, including radio voice communication and electronic data processing and display equipment.

1.5.4 The area of responsibility for control of such a tower should, in addition to aerodrome traffic, also consider all traffic operating within a reasonable distance of the aerodrome. While no precise limitations can be imposed because the distance will vary in accordance with the traffic handled at the moment, experience seems to show, however, that it should normally not exceed 25 NM. Where only VFR traffic is controlled, the designation of a controlled airspace is not necessary and also not generally desirable. However, if the density of VFR traffic reaches proportions which would make the traffic pattern of departing and arriving aircraft difficult because of overflying aircraft, an aerodrome traffic zone may be established to permit the control tower either to exercise control over aircraft not intending to land at the aerodrome in question or to make them avoid that zone.

1.5.5 It should be mentioned here that an aerodrome traffic zone may also be established around uncontrolled aerodromes when the activities conducted at those aerodromes (i.e. flying school, specific military activities) make it undesirable for other aircraft, not engaged in these activities, to penetrate or otherwise disturb the traffic pattern. In this case, the aerodrome traffic zone is primarily reserved for use by aircraft participating in the activities having caused the zone to be established.

1.5.6 When further developments determine that it is necessary for an aerodrome to also be available to traffic operating under IFR, it will be necessary to protect such traffic by extending control to such traffic by imposing such restrictions on VFR flights as are necessary to ensure the safety of both types of operations while operating in the same general area. To accomplish this, sufficient controlled airspace should be established to encompass the arrival,

departure and, where necessary, the holding flight paths of the IFR flights. To achieve this in the most efficient manner, it will generally suffice to establish a comparatively small control zone (which, by definition extends from the ground upwards) and to superimpose on it a control area (which, again by definition, extends from a given lower limit above the ground upwards) of a size sufficient to contain the flight paths of departing, holding and arriving IFR flights. In doing so, the lateral extent of the control zone must be determined in relation to the lower limit of the superimposed control area so that average flight trajectories during departure and arrival are fully contained within the totality of the controlled airspace formed by the control zone and the control area. In addition, care should be taken in establishing the control zone and associated control area, that unnecessary restrictions are not imposed on other VFR air traffic wishing to operate in airspace close to the controlled aerodrome but not wishing to use that aerodrome itself (see also Appendix A to Part I, Section 2, Chapter 3).

1.5.7 Further increases in the number and frequency of IFR traffic at an aerodrome will lead to the need to establish an APP as a separate service which, while closely co-operating with the control tower, may occupy a different location on the aerodrome in question and be administered as a separate ATS unit. The requirement for means and facilities for the provision of this service depend very much on the amount of IFR traffic to be handled, the type of traffic and the complexity of operations, the meteorological and topographical conditions at and around the aerodrome and workload considerations. It may also be possible, depending on demands for this type of service, to limit its availability to those periods of the day where it is likely to be required.

1.5.8 Normally in parallel with the development of air traffic at and around aerodromes, the requirement for the control of air traffic operating between such aerodromes also increases and the need to provide area control service is mainly determined by the assessment of the risk involved in the fact that a number of aircraft operate simultaneously in the same portion of airspace in IMC. If, in addition, a number of these aircraft are engaged in commercial air transport, safety considerations involved in this assessment become even more pressing. However, if such en-route traffic is composed of VFR flights of a non-commercial nature only, it can reach very appreciable proportions before it becomes necessary to institute any type of control over such en-route flights.

1.5.9 In planning ATS it must therefore be ensured that early and timely provisions are made for this eventual increase in traffic because the lead times required for the

initial implementation of an area control service, both as regards staffing and training of personnel and the provision of adequate means and facilities, especially communications, are significantly different from those required for the development and improvement of aerodrome control and APP, which tend to progress along much more envisageable and thus predictable lines. It is for this reason that ICAO has recognized the progressive development of ATS in its provisions of air traffic advisory service as a *temporary, intermediate* stage in the progression from flight information to area control service in order to permit an orderly transition from a service which is primarily informative in nature to one which requires the assumption of increased responsibilities by controllers for the safety of flight operations.

1.5.10 In providing control areas for area control service, their shape and extent will be dictated primarily by the flow of air traffic requiring control. At present, control areas are mainly formed by terminal control areas (TMAs) around major aerodromes connected with each other by air routes. Channelling of air traffic along routes has, however, the advantage that intersections of flight paths will be kept to manageable numbers and that their presentation to controllers on appropriate displays remains within normal limits of human perception.

1.5.11 Other, more liberal forms of organization of the traffic flow, such as the provision of an area control service based on an area type control combined with the possibility of pilots planning their flights along the most direct flight path have been found to be very difficult to accept by controllers. Such arrangements create an instant and continually changing ad hoc route system, determined by the individual intentions of pilots, require an inordinate amount of additional work by controllers in recording and updating flight progress strips, and also seem to render effective control much more difficult because possible conflicts between the intentions of individual flights cannot be projected on to well-established geographical locations but have to be worked out for each case individually.

1.5.12 The development of ACC should, however, provide for the case that, while pilots may still be required to *plan* their flights along a published route structure, ACC will clear them to fly the most direct route between any two points whenever this is possible at the time the flight comes under the control of the ACC concerned. Such a method of control will have to depend to a large measure on the discretion of the controller concerned without the obligation on his part to apply it systematically on each and every occasion. In addition, it must also be ensured that the navigation guidance provided, or the monitoring of flight progress by radar, is adequate to permit pilots to fly such

direct routes with the degree of accuracy upon which separation between aircraft is based.

1.5.13 Finally, the establishment of an ATS route network to support the provision of area control service also offers the possibility of accommodating the various, often diverging interests regarding the channelling of air

traffic. It is therefore essential that, in its establishment, ample opportunity is offered to all airspace users, including the military, as well as other interested parties (e.g. those concerned with the safeguarding of installations on the ground) to participate in the development process and make their views known so that acceptable compromises can be found.

Chapter 2

Types of Service

2.1 INTRODUCTION

The types of air traffic services (ATS) to be provided depend on the objectives of ATS, which are specified in Annex 11, 2.2. As a result, much of what can be said in general terms about type of service has already been covered in the preceding chapter. It is therefore intended that, under this chapter, only a number of specific requirements, peculiar to a particular type of ATS, will be discussed.

2.2 FLIGHT INFORMATION SERVICE

2.2.1 General

2.2.1.1 In general, the flight information service (FIS) is intended to supplement and update during the flight, information on weather, status of navigation aids and other pertinent matters (exercises, airspace reservations, etc.) the pilot received prior to departure from the meteorological (MET) and aeronautical information service (AIS) so as to be fully aware at all times of all relevant details regarding matters influencing the safe and efficient conduct of his flight. The fact that FIS has been entrusted to ATS, even though the information emanates or is generated by other ground services (airport operators, the MET and communications (COM) services), is due to the fact that ATS is the ground service which is most frequently in communication with the pilot. From this it follows that, while ATS is responsible for the transmission of that information, the responsibility for its initiation, accuracy, verification and timely transmission to ATS must rest with its originators.

2.2.1.2 This fact does not, however, apply to information provided in uncontrolled airspace regarding other air traffic operating in the vicinity of a given aircraft. This traffic information should be given whenever it is likely that such information will assist pilots concerned to avoid

the risk of collision. In addition, since, in uncontrolled airspace, such information can only be given about aircraft whose presence is known and since even that information may be of doubtful accuracy as to position and intentions of the aircraft concerned, the unit providing FIS will not assume responsibility for its provision at all times nor for its accuracy once it is issued. Pilots should be given an appropriate indication of this fact when such information is provided to them.

2.2.1.3 Where FIS is the only service provided for en-route traffic, it is generally provided to aircraft by a flight information centre (FIC). Where this service is provided to aircraft on and in the vicinity of a given aerodrome it is referred to as aerodrome flight information service (AFIS). Units providing AFIS need not necessarily form part of the national ATS but may act under delegated authority.

2.2.1.4 With regard to the provision of FIS to en-route traffic, planners should keep in mind that a proper balance must be struck between the obligations imposed on pilots as regards filing of flight plans, reporting of position and closing of flight plans and the possibilities of FIS to use such information effectively in rendering service. It is, for instance, of little use to require flights to make frequent position reports when these are not used to provide an effective collision avoidance service, nor is it useful to have pilots close their flight plans when it serves only administrative purposes. Therefore, the provisions governing uncontrolled flights in FIRs should be seen in relation to the intended development of the FIS to be provided and this, in turn, should be governed by a realistic assessment of potential needs, especially as regards flight safety, and also take into account cost-effectiveness. The provision of air-ground communication cover is particularly relevant in this respect.

2.2.1.5 In a number of States which provide service to a large amount of general aviation flight operations and which cover large areas, it has been found that, rather than to try and provide FIS to these flights from central FICs or special FIS sections, attached to area control centres (ACCs), better service can be provided from strategically located FIS stations, manned by personnel which, while

fully qualified to provide this service, are not fully qualified air traffic controllers. This arrangement may also eliminate the possible need to provide for costly, remote-controlled very high frequency (VHF) communication coverage from one central location in each flight information region (FIR).

2.2.1.5.1 Once established, it was found that it would be both operationally convenient for pilots concerned and economic, if these stations were also to serve as pre-flight briefing stations for pilots not operating from aerodromes where separate MET and AIS units were established. In fact, experience has shown that, with comparatively little additional effort in training and costs, these stations can provide a satisfactory service to general aviation which, otherwise, would have been either very costly and/or would have imposed on pilots undesirable additional efforts to obtain a pre-flight briefing by forcing them to contact two or three different services.

2.2.1.5.2 An example of the above-described method of combining FIS with other services is described in Appendix A.

2.2.2 Aerodrome flight information service

2.2.2.1 Further to the relevant provisions in *Procedures for Air Navigation Services — Rules of the Air and Air Traffic Services* (PANS-RAC, Doc 4444) regarding AFIS, it should be noted that as traffic at and around an aerodrome develops, this type of service should be adjusted so that its provision and its contents meet, at all times, the existing practical requirements. In addition, in many cases, it has been found that the initial stages of AFIS may well be provided by personnel other than ATS, who are required to be available at the aerodrome for other purposes, but have been adequately trained for this task and clear-cut arrangements covering duties and responsibilities have been concluded (see also Part IV, Section 1, Chapter 2, 2.4).

2.2.2.2 However, in those cases where it is envisageable that further aerodrome developments will require the establishment of an aerodrome control tower in the foreseeable future, planning for AFIS should be *implemented* well ahead of the actual requirement, especially as regards the availability of suitably trained personnel.

2.2.2.3 Use of broadcast for FIS

2.2.2.3.1 The provisions in Annex 11 regarding operational flight information service (OFIS) and automatic

terminal information service (ATIS) by means of broadcasting specify what type of information should be provided and how. It is therefore believed unnecessary to repeat these provisions here. However, in the course of development of these services, detailed guidance on the composition of relevant messages has also been developed and is shown in Appendices B to D to this chapter.

2.2.3 Operational flight information service

Trials, conducted in the European (EUR) region with respect to operational flight information service (OFIS) broadcasts, seem to have indicated that OFIS could lead to economies when compared with other methods of providing the same service, provided that:

- a) the information included therein is carefully selected so that it meets the demands of the majority of aircraft using the broadcasts;
- b) the locations from which broadcasts are made are carefully selected so as to cover major terminal areas and traffic arteries with a minimum of overlap;
- c) full advantage is taken of latest developments in the field of automated radio transmission equipment;
- d) requirements in management for the application of the OFIS concept are kept to a minimum.

In addition, it is felt that OFIS would be useful because it could assist users materially in the most economic conduct of their flight operations.

2.2.4 Automatic terminal information service

2.2.4.1 Automatic terminal information service (ATIS) is determined much more by local considerations than is the case for OFIS. It is therefore essential that the question of replacing the individual request/reply method of providing required information to aircraft by a broadcast be reviewed with particular care at each aerodrome, in order to ensure that such action not only offers noticeable operational advantages to the users and the providing ATS unit, but that these advantages are also reasonably cost-effective. Relevant considerations in determining need for ATIS are:

- a) the traffic density at the aerodrome over *prolonged* periods of time. Practical experience noted by one important State seems to show that a minimum of 25 operations per hour during a period of three hours should be the lower limit for establishing a requirement for ATIS;

- b) the frequency with which critical conditions regarding operation to and from the aerodrome in question occur, both meteorological and otherwise;
- c) the composition of the air traffic using the aerodrome from the point of view of aircraft characteristics and resulting departure and approach procedures.

2.2.4.2 In order to be of value, a systematic routine transmission of information must cover the most demanding case, both as regards its contents as well as the range at which it must be received. It could thus well be that, depending on the traffic composition, the provision of ATIS may be dictated by the needs of comparatively few users — a fact that should be kept in mind at all times.

2.2.4.3 It should also be noted that, because of the demand on the coverage of such broadcasts (based on the highest justified demand), implementation of ATIS may result in significant demands on the available radio spectrum (VHF). This, in turn, could increase the difficulties of frequency assignment planners to meet the total demand on VHF channels if these demands are particularly high in a specific area (e.g. the EUR region).

2.2.4.4 It would therefore appear essential that the decision to implement ATIS at a specific location should be made dependent on a study showing that the advantages obtained by it (essentially a reduction in workload imposed on ATS personnel) will outweigh the disadvantages, including those resulting from increased equipment cost involved in the use of this service. In some cases, it may also be advisable to restrict the provision of ATIS to those periods of the day when only traffic density makes ATIS desirable in order to reduce the air-ground communication load on ATS to manageable proportions. It should, however, be noted that such action will do little to resolve frequency congestion problems where they are likely to occur.

2.2.5 Traffic information broadcasts by aircraft and related operating procedures

Where there is a need to supplement collision hazard information to aircraft operating outside of control areas and control zones or in the case of temporary disruption of FIS, traffic information broadcast by aircraft (TIBA) may be applied in designated areas. Guidance material on TIBA and related procedures are contained in Appendix E.

2.3 ALERTING SERVICE

2.3.1 The provision of alerting service is a task incumbent on all ATS and with respect to all air traffic which is known

to an ATS unit. Since the procedures required to perform this service are adequately covered in the relevant part of Annex 11, it is believed sufficient in this manual to stress only one aspect which, in some cases, has given rise to difficulties. This aspect concerns the co-operation with other agencies involved in cases where an aircraft is known or believed to be in a state of emergency, or the subject of unlawful interference.

2.3.2 To cover such co-operation, necessary agreements should be concluded between the parties concerned. These agreements should cover not only procedural aspects as to who is to do what in a given set of circumstances, but should cover also all available communication means which may be used to assist an aircraft in emergency or an aircraft subjected to unlawful interference. Additionally, the names of persons to be contacted along with other relevant information should be included in the agreement. Although cases requiring alerting service are rare, when they do occur they require a perfect functioning of all parties concerned. It is therefore necessary that these arrangements be reviewed at regular intervals and that communication trials be made rather frequently in order to ensure that everybody concerned is fully aware of the agreed provisions and applies them with optimum efficiency. These trials should also permit existing arrangements to be assessed and amended in the light of developments in order to keep them current.

2.3.3 As a number of the organizations involved in a case of unlawful interference with an aircraft will not be too familiar with aviation and its special operating conditions of ATS, it would also appear useful if selected personnel from these organizations were invited to visit ATS installations in order to familiarize themselves with those ATS procedures which may have an effect on the planning of interventions. Such visits could also provide an opportunity for discussion and resolution of problems which are of mutual interest.

2.4 AERODROME CONTROL SERVICE

2.4.1 Further to the provisions in Annex 11 regarding aerodrome control service, there are two aspects which need to be taken into account in their planning and operation. These concern:

- a) the co-operation between the aerodrome control tower and other agencies responsible for the provision of services at the aerodrome where that aerodrome control tower is located;
- b) the internal arrangement for sharing the task of providing aerodrome control service where more than one controller on duty is needed.

2.4.2 With respect to co-operation between the aerodrome control tower and other agencies it is essential that detailed arrangements be concluded between the aerodrome control tower and all those agencies likely to conduct activities on the manoeuvring area of the aerodrome, ensuring that the aerodrome control tower can exercise its control function over aircraft in that area without interference and without creating hazards to aircraft under its control. This applies particularly in those cases when maintenance and/or construction work is being undertaken on the manoeuvring area.

2.4.3 As to the provision of service to aircraft and other traffic operating on the apron, it is now accepted practice that this task should be referred to as the *apron management service* and that this service should be conducted so as to assist pilots and persons in charge of vehicles on the apron to avoid collisions as well as to obtain a coherent pattern of movements on the apron. This service may be achieved by systematic arrangements defining tracks to be followed by the different participants constituting the overall traffic on the apron and/or, by the provision of individual guidance, either by voice or by other, appropriate signal devices. At small and medium aerodromes, where the apron can be fully overseen by the aerodrome control tower, the provision of apron management service is best entrusted to the aerodrome control tower because it retains the unity of service and avoids a change in responsibility for services in the transition area between the apron and the manoeuvring area.

2.4.4 However, at larger aerodromes with extended apron areas, there often exists a situation where the aerodrome control tower cannot oversee the entire apron because of its complexity and it would therefore be unfeasible to entrust the aerodrome control tower with the apron management service. In such cases it will be necessary to have apron management service performed by a special agency which is normally provided by the aerodrome operator. If a special agency performs apron management service it must, however, be ensured that specific agreements are concluded between the ATS unit in question and the aerodrome operator which define, in detail, the respective areas of responsibility on the aerodrome, as well as the procedures to be employed for serving ground traffic. Such arrangements apply especially to methods used in the transition area between the apron and the manoeuvring area so as to avoid any possible incompatibilities between the methods employed.

2.4.5 As to internal arrangements for sharing tasks where more than one controller is on duty (2.4.1 b) above), it is obviously a question which falls largely into the field of facility management (see Part IV, Section 2, Chapter 1).

However, it should also be realized that any arrangements made in this respect should in the first place be dictated by operational considerations, i.e. the safety and efficiency of the service rendered to traffic and not by considerations of administrative convenience or other non-operational considerations.

2.5 APPROACH CONTROL SERVICE

2.5.1 Whenever it has been decided that there is a justified requirement for the provision of approach control (APP) at a specific aerodrome, or for more than one aerodrome if these aerodromes are located in close proximity to each other and it is therefore more effective to provide this service from a single APP, the following aspects, further to the relevant provisions in Annex 11, need to be taken into account in the planning and operation of such a unit:

- a) the co-operative arrangements between APP and the associated aerodrome control tower or aerodrome control towers;
- b) the internal arrangements between controllers for the task of providing APP service;
- c) measures required to ensure that a possible mix of instrument flight rules (IFR) and visual flight rules (VFR) operations at and around the aerodrome(s) in question do not impair the safety of flight operations.

2.5.2 It is evident that the co-operative arrangements between an APP and the associated aerodrome control tower or between APP and aerodrome control towers, when more than one aerodrome is served by a common APP, should be based on considerations of an operational nature only so as to ensure the optimum flow of air traffic, i.e. prevailing MET conditions, composition of arriving and departing air traffic, etc. It is also evident that both APP and the aerodrome control tower(s) should apply maximum flexibility in their operation to obtain best results under any given set of circumstances. One way to achieve flexibility is to provide both APP and the aerodrome control tower(s) with means permitting them to be aware of the traffic situation at each location and assist with appropriate action when the need arises and without the need for lengthy and time-consuming verbal co-ordination.

2.5.3 Means to achieve flexibility could be the installation of a radar display in the control tower, the use of closed-circuit television or other visual displays (video), showing current flight data information for each location. In addition, it must be ensured that voice communication links between APP and the aerodrome control tower are instan-

taneous, reliable and of sufficiently good quality to reduce difficulties to a minimum.

2.5.4 As concerns the internal arrangements for sharing the task of providing APP between controllers (2.5.1 b) refers), experience seems to show that a basic split between those controlling arriving and those controlling departing traffic is the most suitable arrangement, unless other arrangements have been made whereby departing air traffic is directly transferred from the aerodrome control tower to the associated ACC (see Part I, Section 2, Chapter 1, 1.4). In any case, operational considerations aimed at the safe and efficient flow of air traffic should take precedence over any other considerations in the development of such arrangements.

2.5.5 Since approach control is primarily concerned with controlled IFR flights operating at or in the vicinity of aerodromes, it will be faced with the problem of avoiding dangerous situations which could be created by the simultaneous presence of controlled IFR flights and VFR flights in the same airspace. While methods to overcome, or at least reduce, this problem to an acceptable level are at present under study, it appears desirable to mention some basic considerations which are already relevant to this subject.

2.5.5.1 One point which needs to be made first, from an ATS point of view, is that the prohibition of VFR flights at aerodromes where IFR flights are conducted is certainly not the preferred solution to the problem of mixed IFR/VFR flights in the same airspace. Such a course of action will deprive certain users of airspace and facilities which should normally be available to everybody on an equal basis. However, it is also evident that, if there is a likelihood of collision risks, a reasonable degree of interference with the freedom of operation of VFR flights must be accepted, be it that pilots of such flights may be required to have skills not normally required for the conduct of a VFR flight (radiocommunication and/or certain navigation capabilities) and that aircraft must be equipped with certain radiocommunication and/or navigation equipment, or that VFR flights are restricted to certain areas and/or routes and required to comply with procedures additional to those normally required when operating at or around an aerodrome.

2.5.5.2 The choice of measures taken will, to a very large extent, depend on local conditions at the aerodrome in question, as well as on the types of traffic using the aerodrome. It should however, in any case, not be made without full consultation of all parties concerned and should not place unjustifiable demands on VFR pilots, be it in costs required to install supplementary equipment on

board their aircraft or in costs associated with the acquiring and retention of additional skills in the form of special licences, etc. (see also Part II, Section 4, Chapter 2).

2.6 AREA CONTROL SERVICE

2.6.1 In providing area control service the procedures to be applied by an ACC are specified in Annex 11 and are therefore not repeated here. However, there are a number of aspects regarding the provision of area control service which need to be highlighted because they can significantly affect the procedure applied by an ACC. These aspects concern:

- a) the co-ordination and co-operative arrangements made with other air traffic control (ATC) units;
- b) general working arrangements;
- c) control based on the integration and use of radar.

2.6.2 Co-ordination plays an essential part in the provision of area control service and the efficiency of operation of an ACC can be significantly affected by the manner in which this question has been resolved. It should also be noted that co-ordination aspects in an ACC can be broken down into:

- a) co-ordination with adjacent ACCs;
- b) co-ordination with ATC units providing services within the same FIR and served by the ACC in question; and
- c) co-ordination within the ACC concerned.

2.6.3 Co-ordination with adjacent ACCs needs to be conducted frequently because, on an international level, one or more of the ACCs adjacent to the facility in question may be located in a different State due to the geographical configuration of a given area. In cases where only one ACC provides services throughout the territory of a given State, it is frequently found that co-ordination of an ACC with any of its adjacent ACCs involves dealing with the administration of an adjacent State, thus involving different administrative rules and procedures and possibly even different ways of thinking. In those cases, therefore, it is of the utmost importance that the development of appropriate co-ordination arrangements be conducted strictly at the operational level, based on purely operational considerations, and that, to the maximum extent possible, they be kept free of any interference of an administrative or non-technical nature. It should also be pointed out that, whenever possible, such co-ordination arrangements should be developed in meetings between those directly concerned, rather than by correspondence, because it has

been found that such meetings permit the resolution of even complicated issues in appreciably shorter times and with better results than can otherwise be obtained.

2.6.4 Furthermore, any such co-ordination arrangements should be kept under constant review with the objective of their being up-dated whenever it is found that updating is required, either because the conditions upon which the arrangements were based have changed or experience with their application has shown that improvements are possible.

2.6.5 As to co-ordination between an ACC and its associated ATC units, i.e. APP and aerodrome control tower (2.6.2 b) refers), much of what has been said in the previous paragraph also refers, except that this co-ordination normally does not involve two different administrations. However, it is important that in concluding such arrangements they are not influenced by questions of competence or considerations regarding the relative importance of each of the units concerned in relation to the other. This issue is stressed only because past experience in certain areas seems to indicate that, whenever such questions arise, they can seriously affect the efficiency of the arrangements agreed upon and generally take years to correct because of the emotional elements involved.

2.6.6 As regards the internal working arrangements and co-ordination within an ACC (2.6.1 b) and 2.6.2 c) refer), such issues are dealt with in detail in Part IV, Section 2 of the manual. It will therefore be sufficient to state here that internal working arrangements can have a considerable effect, positive as well as negative, on the operation of an ACC in terms of its efficiency and its capacity to handle traffic. Therefore, it is again important that early in the planning stage internal working arrangements for operational personnel be fully incorporated in the planning process and that, wherever possible, simulation trials be conducted, aimed at the determination of the most efficient operational layout of the ACC.

2.6.7 In addition, since the situation in an ACC is subject to frequent changes, mainly due to changes in the amount, density and orientation of traffic flows, it is essential that this matter be kept under review and study so that necessary changes can be effected in good time.

2.6.8 Another aspect relevant to co-ordination involves the situation where an ACC is provided with radar for controlling traffic in part of or throughout its area of responsibility. Normally, the initial control arrangements will be that radar control will be supplementary to the control based on conventional means and that the full integration of radar as a routine means of control will be

effected gradually and only after it has been established that such integration can be done safely. Experience has also shown that, during the period of side-by-side operation of conventional and radar control, increases in the amount of internal co-ordination required generally make it necessary to provide the ACC with air-ground communication channels over and above those required for a fully integrated operation. This side-by-side operation obviously places additional requirements on the available frequency spectrum and can lead to difficulties of an international scale whenever the use of the radio spectrum has already reached critical proportions. It is therefore essential that this stage of the use of radar be kept as short as possible, commensurate with the primary requirement to ensure the continued safety of the service provided and that, upon its completion, the additional voice channel and other requirements be withdrawn so that they again become available to satisfy other justified requirements.

2.7 AIR TRAFFIC ADVISORY SERVICE

2.7.1 As of its inclusion into the relevant ICAO provision, it was intended that air traffic advisory service was to be considered as a *temporary intermediary form of ATS* in order to allow for an orderly and progressive transition from FIS (en-route or around aerodromes) to the provision of ATC. It should therefore be understood that air traffic advisory service cannot and should not constitute an end in itself but should only be instituted to permit control personnel, during a limited period of time, to acquire the necessary experience in the provision of full ATC by allowing them to act as if they were controlling air traffic without assuming the full range of responsibilities which are inherent in its provision.

2.7.2 It is therefore essential that, whenever air traffic advisory service is instituted, it should be clearly explained to users so that no misunderstandings exist as to the quality of service they can expect. It is, however, equally important to request full co-operation in this service so that this transitory stage of development of the ATS can be kept as short as possible. At the same time, it would appear desirable that, from the outset, planners determine a target date (or target dates), in co-operation with the operational personnel concerned, at which time such service will be reviewed with the objective of its upgrading to full ATC.

2.7.3 It should be noted that recently, and in connexion with the problems created by the mixture of IFR and VFR flights around busy aerodromes, some States have insti-

tuted an “air traffic advisory service” to VFR flights which is intended to:

- a) keep such flights separated from IFR flights operating in the same general area;
- b) provide them with advice on the conduct of their flight and on other VFR traffic operating in their vicinity.

Such service is extended to reduce potential risks of collision without the need to impose too restrictive conditions on VFR flights. Should this service become more widespread and thus acknowledged by ICAO, it could change the fundamental concept of the air traffic advisory service.

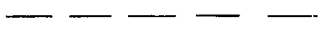

Appendix A

Flight Information Service Combined with other Services

1. In the United States, flight information service (FIS) to flights *not* requiring ATC service is normally provided by flight service stations (FSS). In some cases this service is also provided by aerodrome control towers. FSS accept flight plans, provide pre-flight briefing both as regards MET and AIS and provide normal FIS to aircraft in flight.

2. The meteorological information is not only obtained from current weather reports, forecasts, information on winds aloft, weather maps, etc., as prepared by the meteorological service but is also up-dated by in-flight reports from pilots. Some stations have a telephone connexion to suitably located radar stations, while others located near weather stations provided with such equipment are provided with a repeater display from the weather radar.

3. Other aeronautical information is received through communication connexions to the normal NOTAM distribution system.

4. In many parts of the United States, a limited pre-flight weather briefing can be obtained via a commercial telephone connexion to automatic recording equipment which provides continuously up-dated information. In some parts of the United States, this service has already been further refined to the point where a pilot can dial a number which will connect him with a computer and where, through a series of computer-generated synthetic voice queries and touch-tone telephone replies by the pilot, a more complete weather briefing by synthetic voice is provided. Additionally, the pilot has still the option to call the nearest flight service station or a MET office for additional details, if these are required. However, experience so far has shown that this latter possibility is used only by a small number of pilots.

Appendix B

Contents of the VHF OFIS message

1. INTRODUCTION

1.1 The VHF OFIS message, for use during the en-route phase of the flight, is intended to provide the pilot with the complete range of necessary information about an aerodrome to allow him to make provisional operational decisions about his approach and landing capabilities at that aerodrome. The content of a VHF OFIS message is not as detailed as that in an ATIS message but it should be sufficient to allow pilots to establish general relationship between the aerodrome conditions and the operating capabilities of their aircraft and crew.

1.2 The VHF OFIS message is considered suitable, without variation, both for directed transmissions and for incorporation in broadcasts covering a number of aerodromes. It should be noted that the VHF OFIS broadcast, as well as relieving the load on ATIS, serves to present to the pilot, in one convenient package, the options open to him for continuation of his flight to destination or for diversion to an alternate aerodrome.

1.3 The VHF OFIS message should not include information concerning facilities when it can be reasonably expected that pilots have received that information prior to flight by other means, e.g. NOTAM.

1.4 The contents of a VHF OFIS message for a specific aerodrome may be reduced as deemed necessary when the aerodrome is closed.

2. CONTENTS OF VHF OFIS MESSAGES

VHF OFIS messages should contain the following elements of information in the order listed:

- a) name of aerodrome;
- b) time of observation;
- c) landing runway;
- d) significant runway surface conditions and, if appropriate, braking action;
- e) changes in the operational state of the navigation aids, if appropriate;

- f) holding delay, if appropriate;
- g) surface wind direction and speed; if appropriate, maximum wind speed;
- h) visibility and, when applicable, RVR;
- i) present weather;
- j) clouds below 1 500 m (5 000 ft), or below the highest minimum sector altitude, whichever is greater; cumulonimbus; if the sky is obscured, vertical visibility when available;
- *k) air temperature;
- *l) dew point temperature;
- *m) QNH altimeter setting;
- n) trend-type landing forecast, when available.

*As determined on the basis of regional air navigation agreement.

3. DETAILS ON THE CONTENTS OF EACH ITEM IN THE VHF OFIS MESSAGE

It is emphasized that certain details should, of necessity, be left to the local knowledge and discretion of the originator of the message, bearing in mind the need to adjust the length of the message to the available transmission time. The objective should be to give relevant information which will be applicable for the period during which the message will be transmitted.

3.1 Item 1: Name of aerodrome

The name of the aerodrome should be the official name published in the aeronautical information publication (AIP). When only one aerodrome is associated with a town or island, the name should only be that of the town or island. When the broadcast is made in the English language, the English version of the name, as generally understood, should be used, e.g. AMSTERDAM, MILAN-LINATE; MILAN-MALPENSA.

3.2 Item 2: Time of observation

The time of observation given should be the time in Co-ordinated Universal Time (UTC) included in the

routine report or selected special report (MET report). The other items in the OFIS message, not covered by the MET report, should have the same time of applicability, or as close as is feasible to the time of the MET report. Where the time of observation of operations (OPS) items is significantly different from that of the MET items, the time applicable to each group of items should be stated.

3.3 Item 3: Landing runway

3.3.1 The runway(s) should always be referred to by using the designator established in conformity with Annex 14, 5.2.2.4.

3.3.2 The main runway(s) in use at the time of the observation should be given, e.g. RUNWAY 19; RUNWAY 09 LEFT; RUNWAY 25 LEFT AND 25 RIGHT.

3.3.3 If it is expected that a change in runway is to take place during the period of validity of the broadcast, this change should be included in the item, e.g. RUNWAY 09 EXPECT 24 AFTER 1500.

3.3.4 When the landing runway in use is not a preferential runway, or may be subject to a limiting crosswind, or has degraded approach aids, the non-availability of the preferential runway(s) should be stated, together with the reason and expected duration of this situation, e.g. RUNWAY 34 IN USE; RUNWAY 23 CLOSED SNOW CLEARANCE UNTIL 1930.

3.3.5 When an aerodrome is closed by the aerodrome authority, the reason should be given, e.g. AERODROME CLOSED: SNOW; AERODROME CLOSED: SNOW CLEARANCE; AERODROME CLOSED: EMERGENCY.

3.3.6 When it is possible to estimate the time at which an aerodrome is to be re-opened, then a landing runway should be given if the time until re-opening is less than one hour and it is reasonably certain which runway will then be used. A predicted time should be given, e.g. AERODROME CLOSED SNOW: EXPECT RUNWAY 24 AFTER 1500.

3.4 Item 4: Significant runway surface conditions and, if appropriate, braking action

3.4.1 Significant runway surface conditions affecting the braking action should be briefly described using terms such as the following, e.g.:

(Contaminant) PATCHES	COMPACTED SNOW
(Contaminant) COVERED	DE-ICED
DAMP	SANDED
WET	DRIFTING SAND
FLOODED	RUBBER DEPOSITS
FROZEN RUTS OR RIDGES	

3.4.1.1 The contaminants shall consist of one of the following:

RIME or FROST	DRY SNOW
ICE	WET SNOW
SLUSH	WATER

3.4.2 Where appropriate and feasible the depth of the runway contaminant should be given, measured in millimetres.

3.4.3 If runway available dimensions are less than those published, the length and width of the cleared area on that runway should be given.

3.4.4 The braking action shall consist of the abbreviation "BA" followed by one of the following:

- a) braking action coefficient for each third of the runway and the type of measuring equipment used;
- b) estimated braking action for each third of the runway;
- c) the abbreviation "UNREL" (unreliable).

3.4.4.1 The braking action coefficient shall consist of a six digit group, two digits for each third of the runway, representing the coefficient without the decimal point.

3.4.4.2 The estimated braking action shall consist of a three digit group, one digit for each third of the runway.

Coefficient	Estimate	Description
40 and above	5	good
39 to 36	4	medium to good
35 to 30	3	medium
29 to 26	2	medium to poor
25 and below	1	poor

3.4.4.3 The type of measuring equipment used shall be one of the following:

DBV	Diagonal Braked Vehicle
JBD	James Brake Decelerometer
MUM	Mu-meter
SFT	Friction Tester
SKH	Skiddometer (high pressure tire)
SKL	Skiddometer (low pressure tire)
TAP	Tapley-meter
OTH	Other equipment

3.5 Item 5: Changes in the operational state of the navigation aids, if appropriate

3.5.1 Reports of degradation or unserviceability of facilities should be confined to those facilities upon which approach limitations or procedures directly depend, since at the stage of the flight concerned, the pilot is more interested in knowing whether or not an approach and landing is theoretically possible, vis-à-vis the weather conditions. An instrument landing system (ILS) is the most obvious example of a facility which has a marked effect on approach limitations. When failure of a terminal radar could lead to protracted approach procedures, with consequent effect on fuel margins, it should be given. These reports should normally be restricted to those facilities associated with the approach to the landing runway, unless the degradation or unserviceability (associated with another runway) is the reason for the landing runway being in use.

3.5.2 Facilities which have no effect on approach limitations or procedures should not be reported.

3.5.3 Reports should give a brief description of the degradation or unserviceability, e.g. ILS 14 GLIDE PATH UNRELIABLE; ILS 19 UNSERVICEABLE.

3.5.4 Unserviceability of an ILS and degradation of an operational performance should be given.

3.5.5 If at all possible, an indication of the time at which the unserviceability is expected to be corrected should be given.

3.5.6 A report of restoration of facilities which affect operational limitations should be made immediately upon restoration of the facility in question.

3.6 Item 6: Holding delay, if appropriate

3.6.1 Holding delay for the purpose of VHF OFIS messages is understood to be the total holding time at or immediately prior to the initial approach to the destination

aerodrome, i.e. holding in specified areas over the outer fix(es) and/or over the main navigation aid(s) serving the aerodrome of intended landing, as estimated by ATC.

3.6.2 The information about delays should be based on the actual delays being experienced at the time of the observation and may include an element of forecasting. It may be misleading to give precise delay times; the object must be to give the pilot a broad indication of the average delay so that he may derive a delay expectation for his own flight. The following method is therefore recommended. When the average arrival delay is:

- a) less than 20 minutes, no report should be made;
- b) 20 minutes or more, but less than 45 minutes, the delay should be reported as:
 - 1) DELAY 20 MINUTES; or
 - 2) DELAY 20 MINUTES OR MORE;
- c) 45 minutes or more, the delay should be given as:
 - 1) DELAY 45 MINUTES; or
 - 2) DELAY 45 MINUTES OR MORE.

3.6.3 Where precise delay times are available they may be given, otherwise the method described above should be adhered to.

3.6.4 When available, a trend should be attached to the delay report, indicating whether the delay is increasing or decreasing, e.g. DELAY 45 MINUTES, DECREASING RAPIDLY.

3.7 Item 7: Surface wind direction and speed; if appropriate, maximum wind speed

Guidance on this item should be derived from Annex 3, 4.5. The information should be that contained in the report disseminated beyond the aerodrome (Annex 3, 4.5.5 a) and 4.5.8 refer).

3.8 Item 8: Visibility and, when applicable, runway visual range

Observing and reporting of visibility and runway visual range (RVR) are governed by the relevant ICAO provisions in Annex 3, 4.6 and 4.7. The criteria applicable to reports disseminated beyond the aerodrome should be used as given in 4.7.14. With regard to RVR, only the value representative of the touchdown zone should be given and no indication of location on the runway should be included. When there is more than one runway in use and there are significant differences in runway visual range between those runways, values for more than one runway

should be included in accordance with agreement between the meteorological authorities and the operators concerned and the runways to which the values refer should be indicated in the form “RWY 26 RVR 500 M RWY 20 RVR 800 M” (Annex 3, 4.7.14 refers).

3.9 Item 9: Present weather

Guidance on observing and reporting of present weather is given in Annex 3, 4.8.

3.10 Item 10: Clouds below 1 500 m (5 000 ft), or below the highest minimum sector altitude, whichever is greater; cumulonimbus; if the sky is obscured, vertical visibility when available

Guidance on observing and reporting of cloud is given in Annex 3, 4.9.

3.11 Items 11, 12 and 13: air temperature, dew point temperature and QNH altimeter setting

Annex 3, 4.10 and 4.11 provide guidance on the air temperature, dew point temperature and QNH altimeter setting. It should be noted that in accordance with 4.10.4 and 4.11.5 the above parameters should only be included if required by regional air navigation agreement.

3.12 Item 14: Trend-type landing forecasts, when available

The description and procedures applicable to the preparation of trend-type landing forecasts are indicated in Annex 3, 6.3.4 to 6.3.12. Aerodromes originating this type of forecast are listed in the regional air navigation plan.

Appendix C

Contents of the HF OFIS Message

1. INTRODUCTION

1.1 The HF operational flight information service (OFIS) message, for use during the en-route phase of the flight, is intended to provide the pilot with necessary information about an aerodrome to allow him to make provisional, operational decisions about his approach and landing capabilities at that aerodrome. The contents of an HF OFIS message are not as detailed as that in an ATIS message but should be sufficient enough to allow pilots to establish a general relationship to be established between the aerodrome conditions and the operating capabilities of their aircraft and crew.

1.2 The HF OFIS message is considered suitable, without variation, both for directed transmissions and for incorporation in broadcasts covering a number of aerodromes. It should be noted that the HF OFIS broadcast, as well as relieving the load on ATS, serves to present to the pilot, in one convenient package, the options open to him for continuation of his flight to destination or for a diversion to an alternate aerodrome.

1.3 The HF OFIS message should not include information concerning facilities when it can be reasonably expected that pilots have received that information prior to flight by other means, e.g. NOTAM.

1.4 The contents of an HF OFIS message for a specific aerodrome may be reduced as deemed necessary when the aerodrome is closed.

2. CONTENTS OF HF OFIS MESSAGES

2.1 The contents of HF OFIS messages should be as determined on the basis of regional air navigation agreement. In areas where VHF OFIS broadcasts are not available or are rarely employed, the contents of the HF OFIS broadcast may have to be altered to comprise items listed under VHF OFIS broadcasts.

2.2 Normally HF OFIS messages should contain the following elements of information in the order listed:

2.2.1 *Item a: Information on significant en-route weather phenomena*

Information on significant en-route weather phenomena should be in the form of available SIGMETs as prescribed in Annex 3.

2.2.2 *Item b: Aerodrome information including:*

- a) name of aerodrome;
- b) time of observation;
- c) holding delay, if appropriate;
- d) surface wind direction and speed; if appropriate, maximum wind speed;
- e) visibility and, when applicable, RVR;
- f) present weather;
- g) cloud below 1 500 m (5 000 ft), or below the highest minimum sector altitude, whichever is greater; cumulonimbus; if the sky is obscured, vertical visibility when available;
- h) aerodrome forecast.

3. DETAILS ON THE CONTENTS OF THE HF OFIS MESSAGE

Procedures associated with preparation, format and exchange of SIGMET messages are described in Annex 3, 7.1 and 7.2. These messages should be included in HF OFIS broadcasts if time is available; otherwise, reference should be made to the existence of SIGMET messages. If there is no SIGMET message, the provisions in 11.4.6 of Annex 3, concerning the reporting of "NIL SIGMET" should apply.

3.1 **Item 1: Name of aerodrome**

The name of the aerodrome should be the official name published in the AIP. When only one aerodrome is associated with a town or island, the name should only be that of the town or island. When the broadcast is made in the English language, the English version of the name, as generally understood, should be used, e.g. AMSTERDAM, MILAN-LINATE, MILAN-MALPENSA.

3.2 Item 2: Time of observation

The time of observation given should be the time in UTC included in the routine report or selected special report (MET report). The other items in the OFIS message, not covered by the MET report, should have the same time of applicability, or as close as is feasible to the time of the MET report. Where the time of observation of OPS items is significantly different from that of the MET items, the time applicable to each group of items should be stated.

3.3 Item 3: Holding delay, if appropriate

3.3.1 Holding delay for the purpose of HF OFIS messages is understood to be the total holding time at or immediately prior to the initial approach to the destination aerodrome, i.e. holding in specified areas over the outer fix(es) and/or over the main navigation aid(s) serving the aerodrome of intended landing, as estimated by ATC.

3.3.2 The information about delays should be based on the actual delays being experienced at the time of the observation and may include an element of forecasting. Since it may be misleading to give precise delay times; the object must be to give the pilot a broad indication of the average delay so that he may derive a delay expectation for his own flight. The following method is therefore recommended. When the average arrival delay is:

- a) less than 20 minutes, no report should be made;
- b) 20 minutes or more, but less than 45 minutes, the delay should be reported as:
 - 1) DELAY 20 MINUTES; or
 - 2) DELAY 20 MINUTES OR MORE;
- c) 45 minutes or more, the delay should be given as:
 - 1) DELAY 45 MINUTES; or
 - 2) DELAY 45 MINUTES OR MORE.

3.3.3 Where precise delay times are available they may be given, otherwise the method described above should be adhered to.

3.3.4 When available, a trend should be attached to the delay report, indicating whether the delay is increasing or decreasing, e.g. DELAY 45 MINUTES, DECREASING RAPIDLY.

3.4 Item 4: Surface wind direction and speed; if appropriate, maximum wind speed

Guidance on this item should be derived from Annex 3, 4.5. The information should be that contained in the report disseminated beyond the aerodrome (Annex 3, 4.5.5 a) and 4.5.8 refer).

3.5 Item 5: Visibility and, when applicable, RVR

Observing and reporting of visibility and RVR are governed by the relevant ICAO provisions in Annex 3, 4.6 and 4.7. The criteria applicable to reports disseminated beyond the aerodrome should be used as given in 4.7.14; specifically that with regard to RVR, only the value representative of the touch-down zone should be given and no indication of location on the runway should be included. When there is more than one runway in use and there are significant differences in RVR between those runways, values for more than one runway should be included in accordance with agreement between the meteorological authorities and the operators concerned and the runways to which the values refer should be indicated in the form "RWY 26 RVR 500 M RWY 20 RVR 800 M" (4.7.14 refers).

3.6 Item 6: Present weather

Guidance on observing and reporting of present weather is given in Annex 3, 4.8.

3.7 Item 7: Clouds below 1 500 m (5 000 ft), or below the highest minimum sector altitude, whichever is greater; cumulonimbus; if the sky is obscured, vertical visibility when available

Guidance on observing and reporting of cloud is given in Annex 3, 4.9.

3.8 Item 8: Aerodrome forecast

Annex 3, Chapter 6, 6.2 provides guidance on the preparation and use of aerodrome forecasts.

Appendix D

Contents of the ATIS Message

1. INTRODUCTION

1.1 The automatic terminal information service (ATIS) message is intended to provide the pilot with the complete range of information about an aerodrome necessary to allow him to make a definite decision about his approach and landing or his take-off.

1.2 The ATIS message is transmitted in the form of a broadcast at those aerodromes where, due to traffic density, there is a requirement for a reduction in communication load on the ATS VHF air-ground channels and thus a consequent reduction on the workload of controllers. However, there are times when it is also suitable for controllers to provide for individual direct transmission to pilots when the use of a broadcast is not warranted.

1.3 Where ATIS broadcasting is used, the ATIS message may be combined into one broadcast, serving both arriving and departing traffic or, where required by circumstances, it may be split into one addressed specifically to arriving and one addressed to departing traffic. In the latter case, the contents of the respective ATIS messages need to be adjusted accordingly (see 4).

2. CONTENTS OF THE ATIS MESSAGE

ATIS messages should contain all or part of the following elements of information in the order listed:

- a) name of aerodrome;
- b) designator;
- c) time of observation, if appropriate;
- d) type of approach to be expected;
- e) the runway(s) in use; status of arresting system constituting a potential hazard, if any;
- f) significant runway surface conditions, and if appropriate, braking action;
- g) holding delay, if appropriate;
- h) transition level, if applicable;
- i) other essential operational information, if appropriate;
- j) surface wind direction and speed, including significant variations;

- k) visibility and, when applicable, RVR;
- l) present weather;
- m) cloud below 1 500 m (5 000 ft) or below the highest minimum sector altitude, whichever is greater; cumulonimbus; if the sky is obscured, vertical visibility when available;
- n) air temperature;
- o) dew point temperature;
- p) altimeter setting(s);
- q) any available information on significant meteorological phenomena in the approach, take-off and climb-out areas;
- r) trend-type landing forecast, when available;
- s) specific ATIS instructions.

3. DETAILS OF THE CONTENTS OF EACH ITEM IN THE ATIS MESSAGE

3.1 Item 1: Name of aerodrome

The name of the aerodrome should be the official name published in the AIP. When only one aerodrome is associated with a town or island, the name should only be that of the town or island. When the broadcast is made in the English language, the English version of the name, as generally understood, should be used, e.g. AMSTERDAM, MILAN-LINATE, MILAN-MALPENSA.

3.2 Item 2: Designator

Following the name of the aerodrome each ATIS message should commence with one of the following terms as appropriate, e.g. INFORMATION, ARRIVAL INFORMATION, DEPARTURE INFORMATION; followed by the specific letter of the ICAO radiotelephony spelling alphabet used sequentially, e.g. for combined arrival/departure ATIS — INFORMATION ALPHA; for arrival ATIS — ARRIVAL INFORMATION ALPHA; for departure ATIS — DEPARTURE INFORMATION ALPHA.

3.3 Item 3: Time of observation

The time of observation given should be the time in Co-ordinated Universal Time (UTC) included in the routine report or selected special report (MET report). The other items in the OFIS message, not covered by the MET report, should have the same time of applicability, or as close as is feasible to the time of the MET report. Where the time of observation of operations items is significantly different from that of the MET items, the time applicable to each group of items should be stated.

3.4 Item 4: Type of approach to be expected

Where a number of approach procedures are available to a runway, the one in use is to be advised, e.g. VHF omnidirectional radio range (VOR), distance measuring equipment (DME), APPROACH or ILS APPROACH.

3.5 Item 5: The runway(s) in use, status of arresting system constituting a potential hazard, if any

3.5.1 When different runways are used for landing and take-off, the landing runway(s) should be specified first followed by the significant runway surface conditions, and where appropriate, the braking action. This information should be followed by stating the runway(s) to be used for take-off and significant runway surface conditions, and if appropriate, the braking action.

3.5.2 The runway(s) should always be referred to by using the designator established in conformity with Annex 14, 5.2.2.4.

3.5.3 The runway(s) in use at the time of the observation should be given, e.g. RUNWAY 19; RUNWAY 09 LEFT; RUNWAY 25 LEFT AND 25 RIGHT; ARRIVALS RUNWAY 25 LEFT, DEPARTURES RUNWAY 25 RIGHT.

3.5.4 If it is expected that a change in runway is to take place during the period of validity of the broadcast, this change should be included in the item, e.g. RUNWAY 09 EXPECT 24 AFTER 1500.

3.5.5 When the runway in use is not a preferential runway, or the runway may be subject to a limiting crosswind, or the landing runway has degraded approach aids, the non-availability of the preferential runway(s) should be stated, together with the reason and expected duration of this situation, e.g. RUNWAY 34 IN USE;

RUNWAY 23 CLOSED SNOW CLEARANCE UNTIL 1930.

3.5.6 Where an arresting system constitutes a potential hazard on the runway, information should be provided accordingly.

3.6 Item 6: Significant runway surface conditions

3.6.1 The significant runway surface conditions affecting braking action should be briefly described to both arrival and departure runways, as appropriate, using terms such as the following, e.g.

(Contaminant) PATCHES	COMPACTED SNOW
(Contaminant) COVERED	DE-ICED
DAMP	SANDED
WET	DRIFTING SAND
FLOODED	RUBBER DEPOSITS
FROZEN RUTS OR RIDGES	

3.6.1.1 The contaminants shall consist of one of the following:

RIME or FROST	DRY SNOW
ICE	WET SNOW
SLUSH	WATER

3.6.2 Where appropriate and feasible the depth of the runway contaminant should be given, measured in millimetres.

3.6.3 If runway available dimensions are less than those published the length and width of the cleared area on the runway should be given.

3.6.4 The braking action shall consist of the abbreviation "BA" followed by one of the following:

- braking action coefficient for each third of the runway and the type of measuring equipment used;
- estimated braking action for each third of the runway;
- the abbreviation "UNREL" (unreliable).

3.6.4.1 The braking action coefficient shall consist of a six digit group, two digits for each third of the runway, representing the coefficient without the decimal point.

3.6.4.2 The estimated braking action shall consist of a three digit group, one digit for each third of the runway.

Coefficient	Estimate	Description
40 and above	5	good
39 to 36	4	medium to good
35 to 30	3	medium
29 to 26	2	medium to poor
25 and below	1	poor

3.6.4.3 The type of measuring equipment used shall be one of the following:

DBV	Diagonal Braked Vehicle
JBD	James Brake Decelerometer
MUM	Mu-meter
SFT	Friction Tester
SKH	Skiddometer (high pressure tire)
SKL	Skiddometer (low pressure tire)
TAP	Tapley-meter
OTH	Other equipment

3.7 Item 7: Holding delay

3.7.1 Holding delay for the purpose of ATIS broadcast messages is understood to be the total holding time at or immediately prior to the initial approach to the destination aerodrome, i.e. holding in specified areas over the outer fix(es) and/or over the main navigation aid(s) serving the aerodrome of intended landing, as estimated by ATC.

3.7.2 The information about delays should be based on the actual delays being experienced at the time of the observation and may include an element of forecasting.

3.7.3 The following method is therefore recommended when the arrival delay is:

- a) less than 20 minutes, normally no report should be made except when more precise information is possible;
- b) 20 minutes or more, delay should be reported in 10-minute intervals, e.g. DELAY 20 MINUTES; DELAY 30 MINUTES.

3.7.4 When available, a trend should be attached to the delay report, indicating whether the delay is increasing or decreasing, e.g. DELAY 40 MINUTES, DECREASING RAPIDLY.

3.7.5 Information on precise holding delay should be given by ATC through directed transmission in the form of expected approach time in accordance with procedures as laid down in the PANS-RAC, Part IV, 12.1.

3.8 Item 8: Transition level

If the transition level is variable, or if it differs from the published level, it should be included.

3.9 Item 9: Other essential operational information, if appropriate

Pertinent operational information should be included.

3.10 Item 10: Surface wind direction and speed

Guidance on reporting surface wind direction and speed should be derived from Annex 3, 4.5. The information should be that contained in the reports used at the aerodrome of origination, i.e. 4.5.5 a) and 4.5.8 of Annex 3 are not applicable to ATIS reports.

3.11 Item 11: Visibility and, when applicable, RVR

Guidance on this item is contained in Annex 3, 4.6 and 4.7. The information should be that contained in the reports used at the aerodrome of origin, i.e. the last sentence of 4.6.2 and 4.7.14 of Annex 3 are not applicable.

3.12 Item 12: Present weather

Guidance on observing and reporting of present weather is given in Annex 3, 4.8.

3.13 Item 13: Clouds below 1 500 m (5 000 ft)

Guidance on observing and reporting of cloud is given in Annex 3, 4.9.

3.14 Item 14: Air temperature

The air temperature should be air temperature representative of the runway(s). Relevant guidance material as contained in Annex 3, 4.10.

3.15 Item 15: Dew point temperature

Guidance on observing and reporting dew point is given in Annex 3, 4.10.

3.16 Item 16: Altimeter setting(s)

QNH value should always be given and, if locally agreed, the QFE value may be added.

3.17 Item 17: Any available information on significant meteorological information in the approach, take-off and climb-out areas

3.17.1 Available information on meteorological conditions in the approach, missed approach or climb-out area relating to the location of cumulonimbus or thunderstorm, moderate or severe turbulence, hail, severe line squall, moderate or severe icing, freezing rain, marked mountain waves, sand storm, dust storm, blowing snow, tornado or waterspout, as well as any information on fog dispersal operations in progress should be included.

3.17.2 In addition any information on wind shear along the flight path and on marked temperature inversion should be given.

3.18 Item 18: Trend-type landing forecast

The description and procedures applicable to the preparation of trend-type landing forecasts are indicated in Annex 3, 6.3.4 to 6.3.12. Aerodromes originating this type of forecast are listed in Table MET 1 of the regional air navigation plan.

3.19 Item 19: Specific ATIS instructions

Instructions should be given to the pilot to acknowledge receipt of the ATIS message upon initial contact with the appropriate control agency using the phonetic alphabetic code given in the ATIS broadcast. Special communication instructions may be added.

4. COMPOSITION OF SPECIFIC ATIS MESSAGES

Paragraph 2 specifies the various items to be included in an ATIS message, while 3 gives the details of the contents of each of these items. It is, however, specified that, depending on circumstances, ATIS can be provided either as a combined arrival/departure ATIS message, or that it can be split into an arrival and a departure ATIS message. The following table shows, therefore, which items, as described in 2 and 3, should be included in each of these three possible ATIS messages:

Item	Combined ARR/DEP	ARR only	DEP only
1	X	X	X
2	X	X	X
3	X	X	X
4	X	X	—
5	X	X	X
6	X	X	X
7	X	X	—
8	X	X	—
9	X	X	X
10	X	X	X
11	X	X	X
12	X	X	—
13	X	X	X
14	X	X	X
15	X	X	X
16	X	X	X
17	X	X ¹	X ²
18	X	X	—
19	X	X	X

1. Related to the approach area only.

2. Related to the take-off and climb-out area only.

Appendix E

Traffic Information Broadcasts by Aircraft and Related Operating Procedures

INTRODUCTION

Traffic information broadcasts by aircraft are intended to permit reports and relevant supplementary information of an advisory nature to be transmitted by pilots on a designated VHF radio telephone (RTF) frequency for the information of pilots of other aircraft in the vicinity.

TRAFFIC INFORMATION BROADCASTS BY AIRCRAFT (TIBA)

1. INTRODUCTION AND APPLICABILITY OF BROADCASTS

1.1 TIBAs should be introduced only when necessary and as a temporary measure.

1.2 The broadcast procedures should be applied in designated airspaces where:

- a) there is a need to supplement collision hazard information provided by air traffic services outside controlled airspace; or
- b) there is a temporary disruption of normal air traffic services.

1.3 Such airspaces should be identified by the States responsible for provision of air traffic services within these airspaces, if necessary with the assistance of the appropriate ICAO regional office(s), and duly promulgated in aeronautical information publications or NOTAMs, together with the VHF RTF frequency, the message formats and the procedures to be used. Where, in the case of 1.2 a) above, more than one State is involved, the airspace should be designated on the basis of regional air navigation agreement and promulgated in *Regional Supplementary Procedures* (Doc 7030).

1.4 When establishing a designated airspace, dates for the review of its applicability at intervals not exceeding 12 months should be agreed by the appropriate ATS authority(ies).

2. DETAILS OF BROADCASTS

2.1 VHF RTF frequency to be used

2.1.1 The VHF RTF frequency to be used should be determined and promulgated on a regional basis. However, in the case of temporary disruption occurring in controlled airspace, the States responsible may promulgate, as the VHF RTF frequency to be used within the limits of that airspace, a frequency used normally for the provision of air traffic control service within that airspace.

2.1.2 Where VHF is used for air-ground communications with ATS and an aircraft has only two serviceable VHF sets, one should be tuned to the appropriate ATS frequency and the other to the TIBA frequency.

2.2 Listening watch

2.2.1 A listening watch should be maintained on the TIBA frequency 10 minutes before entering the designated airspace until leaving this airspace. For an aircraft taking off from an aerodrome located within the lateral limits of the designated airspace listening watch should start as soon as appropriate after take-off and be maintained until leaving the airspace.

2.3 Time of broadcasts

2.3.1 A broadcast should be made:

- a) 10 minutes before entering the designated airspace or, for a pilot taking off from an aerodrome located within the lateral limits of the designated airspace, as soon as appropriate after take-off;
- b) 10 minutes prior to crossing a reporting point;
- c) 10 minutes prior to crossing or joining an ATS route;
- d) at 20-minute intervals between distant reporting points;
- e) 2 to 5 minutes, where possible, before a change in flight level;
- f) at the time of a change in flight level; and
- g) at any other time considered necessary by the pilot.

2.4 Forms of broadcast

2.4.1 The broadcasts other than those indicating changes in flight level, i.e., the broadcasts referred to in 2.3.1 a), b), c), d) and g), should be in the following form:

ALL STATIONS (necessary to identify a traffic formation broadcast)
 (call sign)
 FLIGHT LEVEL (number) (or CLIMBING* TO FLIGHT LEVEL (number))
 (direction)
 (ATS route) (or DIRECT FROM (position) TO (position))
 POSITION (position**) AT (time)
 ESTIMATING (next reporting point, or the point of crossing or joining a designated ATS route) AT (time)
 (call sign)
 FLIGHT LEVEL (number)
 (direction)

*For the broadcast referred to in 2.3.1 a) in the case of an aircraft taking off from an aerodrome located within the lateral limits of the designated airspace.

**For broadcasts made when the aircraft is not near an ATS significant point, the position should be given as accurately as possible and in any case to the nearest 30 minutes of latitude and longitude.

Fictitious example:

“ALL STATIONS WINDAR 671 FLIGHT LEVEL 350 NORTHWEST BOUND DIRECT FROM PUNTA SAGA TO PAMPA POSITION 5040 SOUTH 2010 EAST AT 2358 ESTIMATING CROSSING ROUTE LIMA THREE ONE AT 4930 SOUTH 1920 EAST AT 0012 WINDAR 671 FLIGHT LEVEL 350 NORTHWEST BOUND OUT”

2.4.2 Before a change in flight level, the broadcast (referred to in 2.3.1 e)) should be in the following form:

ALL STATIONS
 (call sign)
 (direction)
 (ATS route) (or DIRECT FROM (position) TO (position))
 LEAVING FLIGHT LEVEL (number) FOR FLIGHT LEVEL (number) AT (position and time)

2.4.3 Except as provided in 2.4.4, the broadcast at the time of a change in flight level (referred to in 2.3.1 f)) should be in the following form:

ALL STATIONS
 (call sign)
 (direction)
 (ATS route) (or DIRECT FROM (position) TO (position))
 LEAVING FLIGHT LEVEL (number) NOW FOR FLIGHT LEVEL (number)

followed by:

ALL STATIONS
 (call sign)
 MAINTAINING FLIGHT LEVEL (number)

2.4.4 Broadcasts reporting a temporary flight level change to avoid an imminent collision risk should be in the following form:

ALL STATIONS
 (call sign)
 LEAVING FLIGHT LEVEL (number) NOW FOR FLIGHT LEVEL (number)

followed as soon as practicable by:

ALL STATIONS
 (call sign)
 RETURNING TO FLIGHT LEVEL (number) NOW

2.5 Acknowledgement of the broadcasts

2.5.1 The broadcasts should not be acknowledged unless a potential collision risk is perceived.

3. RELATED OPERATING PROCEDURES

3.1 Changes of cruising level

3.1.1 Cruising level changes should not be made within the designated airspace, unless considered necessary by pilots to avoid traffic conflicts, for weather avoidance or for other valid operational reasons.

3.1.2 When cruising level changes are unavoidable, all available aircraft lighting which would improve the visual detection of the aircraft should be displayed while changing levels.

3.2 Collision avoidance

3.2.1 If, on receipt of a traffic information broadcast from another aircraft, a pilot decides that immediate action is necessary to avoid an imminent collision risk to his aircraft, and this cannot be achieved in accordance with the right-of-way provisions of Annex 2, he should:

- a) unless an alternative manoeuvre appears more appropriate, immediately descend 1 000 ft if above FL 290, or 500 ft if at or below FL 290;

- b) display all available aircraft lighting which would improve the visual detection of the aircraft;
- c) as soon as possible, reply to the broadcast advising action being taken;
- d) notify the action taken on the appropriate ATS frequency; and
- e) as soon as practicable, resume normal flight level, notifying the action on the appropriate ATS frequency.

3.3 Normal position reporting procedures

3.3.1 Normal position reporting procedures should be continued at all times, regardless of any action taken to initiate or acknowledge a traffic information broadcast.

Chapter 3

Airspace Organization

3.1 INTRODUCTION

3.1.1 Ideally, the organization of the airspace over a given area should be arranged so that it corresponds to operational and technical considerations only. This is a concept which, in view of the many divergent and sometimes contradicting demands made on its use can, however, never be achieved other than by approximation of a more or less satisfactory nature. It is therefore believed to be more useful, if a number of principles were listed here which, when judiciously applied, should permit an acceptable compromise to be reached in this field of airspace organization.

3.1.2 In planning the organization of the airspace, the first point to be made is that none of those laying claim to its use should attempt to exploit his advantages because he finds himself momentarily in a position of strength (be it political or numerical) when compared with that of other parties. Experience has shown that, over a longer period, such positions tend to change with the effect that, when they do, others will then exploit their temporary advantages, thus setting the stage for a course of events which, in the long run, is damaging to all parties concerned and to the air traffic services (ATS) system of the States concerned.

3.1.3 The second point, following directly from the first, is that any airspace organization must provide for an equitable sharing of its use by all those having a legitimate interest in it. In this respect, it has been found that, to resort to segregation of the airspace, i.e. its splitting and subsequent systematic allocation to the exclusive use by a specific party, generally results in the least efficient over-all use of the available airspace as it invariably leads to a sterilization of large portions of the airspace for prolonged periods of time. The objective should therefore be to organize the airspace so that it can be used in the most flexible way, through co-ordinated, or better yet, combined use by as many parties as possible. This applies particularly with respect to the two major groups of users, i.e. the civil and military (see also Part I, Section 2, Chapter 1, 1.1.4 and Part II, Section 1, Chapter 2).

3.1.4 A third point to be borne in mind in this respect is that, because of the international character of many aircraft operations, the organization of the airspace over one State can hardly be looked at in isolation but must, by necessity, be seen as an integral part of a much wider system covering, in general, not less than an ICAO region. It is therefore essential that States co-ordinate any modifications to airspace organizations at the required level.

3.2 DESIGNATION AND ESTABLISHMENT OF SPECIFIC PORTIONS OF THE AIRSPACE

3.2.1 The relevant provisions in Annex 11, 2.5 specify that, once it has been decided that ATS are to be provided, the airspace, wherein such services are rendered, should be designated by the following terms:

- a) flight information region (FIR);
- b) control area (CTA);
- c) control zone.

In addition, aerodromes where air traffic control (ATC) is provided, should be designated as controlled aerodromes.

3.2.2 FIRs normally encompass the entire airspace over the territory of a State. Adjacent FIRs should be contiguous and, if possible, be delineated so that operational considerations regarding the route structure encompassed by them take precedence over their alignment along national borders (see also Part I, Section 2, Chapter 1, 1.3). The decision to establish more than one FIR to cover the airspace over a State is, for obvious reasons, not only primarily dependent on the size of the State concerned but also dependent on the air route structure extending over the State, its topography and, last but not least, cost-effectiveness considerations and the need to keep facility management problems of the ATS units providing services in them to manageable proportions.

3.2.3 With regard to the delineation of FIR boundaries over the high seas, these will, in any case, be subject to

regional air navigation agreement and should be based on the existing and expected air route structure as well as on the ability of selected provider States to furnish the required services without undue efforts.

3.2.4 CTAs should be established so that they cover that airspace which will encompass the flight paths of those instrument flight rules (IFR) flights within an FIR to which it is believed necessary to provide ATC. When deciding whether or not ATC should be provided, the following should, among other factors, be taken into account:

- a) the desire of operators of flights concerned to obtain that service;
- b) the types and density of air traffic at any moment or during specific periods and the resulting risk of possible collisions between flights;
- c) the prevailing meteorological conditions;
- d) other relevant factors of a local nature, i.e. the general topography; hospitability of the area overflown, etc.

3.2.5 ATC service may be suspended under the following conditions:

- a) when traffic density and/or complexity along certain routes followed by aircraft decreases below the critical point; or
- b) when traffic density and/or complexity, on which the requirement for ATC is based, is limited to definable periods of time.

3.2.6 CTAs can be formed by:

- a) terminal control areas (TMAs) of sufficient size to contain the controlled traffic around the busier aerodromes;
- b) interconnecting airways of:
 - 1) a lateral extent determined by the accuracy of track-keeping of aircraft operating on them, as well as the navigation means available to aircraft and their capability to exploit them;
 - 2) a vertical extent covering all levels required to be provided with control service; or
- c) area-type control areas within which specific ATS routes have been defined for the purpose of flight planning and which provide for the organization of an orderly traffic flow;
- d) in the case of oceanic airspace, control areas may be achieved by the establishment of one or more route structures serving specific traffic flows; or if the complexity of oceanic ATS routes so warrants, by the establishment of an area type oceanic control area.

3.2.7 Control area arrangements have the advantage that, whenever traffic conditions permit, ATC may authorize specific flights under its control to deviate from the established ATS routes or route structure, normally in order to follow a more direct flight path between specified points along its route, without aircraft leaving controlled airspace and thus losing the benefit of ATC.

3.2.8 In certain areas, it could also be desirable to divide FIRs and CTAs so that an upper and a lower airspace is provided along a vertical plane. When this is done, an FIR and/or CTA in the upper airspace may laterally encompass the areas of more than one lower FIR or CTA. However, the lateral limit of such an upper FIR or CTA should, in any case, coincide with the corresponding peripheral lateral limits of the underlying FIRs or CTAs encompassed by the upper FIR/CTA, in order to retain the necessary compatibility in the transfer of responsibility for aircraft between adjacent ATS units in the lower and in the upper airspace (see Appendix A, Figure A-6).

3.2.9 The reasons for the vertical division of airspace as described above can be two-fold:

- a) either to split the workload of ATS so that the workload imposed on one ATS unit remains within manageable proportions, both as to its area of responsibility and the amount of traffic it is required to handle; or
- b) to apply to air traffic operating in the upper airspace, operating conditions which are different from those applied in the lower airspace and which are motivated by operating parameters which are peculiar to traffic operating in that airspace (e.g. prohibition to operate in accordance with visual flight rules (VFR), use of the area-type control versus the airway type, etc.); or
- c) a combination of a) and b) above.

In any case, if such a vertical split is made, it should be ensured that the plane of division, chosen for the reasons under a) above, is not different from that chosen for the reasons given in b) above because it will complicate procedures for pilots as well as for controllers. Furthermore, the plane of division chosen by one State should be carefully co-ordinated with adjacent States in order to avoid transition and co-ordination difficulties at the transfer points. Whenever possible, such a plane should be established uniformly over the largest possible area and the borderlines between different planes of division, if these must exist, should be placed where they have the least detrimental effect on pilots and ATC.

3.2.10 Further to what has already been said (Part I, Section 2, Chapter 1, 1.5.5 and 1.5.6) with respect to control zones and aerodrome traffic zones, it appears

sufficient to stress once more that control zones should be kept as small as possible, consistent with the need to accommodate the flight paths of controlled IFR flights between the lower limits of a CTA and the aerodrome for which the control zone is established. In addition, their size may also be influenced by the need to permit special VFR operations around the aerodrome in question. As to aerodrome traffic zones, these should only be established where the activities requiring their establishment are of sufficiently frequent duration and involve a reasonably large number of aircraft.

3.2.11 From the nature of the air traffic advisory service, as described in Part I, Section 2, Chapter 2, 2.7, it follows that the establishment of advisory airspace should be governed by what has been said for the establishment of CTAs and control zones as to their extent and configuration. In fact, such airspace should be considered as the precursor of controlled airspace during that period when air traffic advisory service is provided in anticipation of full ATC.

3.3 AIRSPACE RESTRICTIONS AND RESERVATIONS

3.3.1 General

3.3.1.1 Since the demands on the use of airspace are manifold, some of which are not compatible with civil aviation (e.g. rocket firing) and because there exist sensitive areas on the ground which need protection from possible disturbance by overflying aircraft, it is recognized that there will be a need for States to establish airspace restrictions of varying degrees of severity. In addition, there are aerial activities by specific users or user groups which may require the reservation of portions of the airspace for their exclusive use for determined periods of time.

3.3.1.2 Whenever such restrictions and/or reservations have to be imposed, they invariably constitute a limitation to the free and unhampered use of that airspace with the associated restrictive effects on flight operations. It is therefore evident that the scope and duration of restrictions established should be subject to very stringent scrutiny in order to keep undesirable effects to the minimum consistent with the reasons causing their creation. To achieve this, it will be essential to create appropriate methods or organizations, in which all users and providers are adequately represented, for screening requests for airspace restrictions or reservations.

3.3.1.3 Such methods or organizations should:

- a) ensure that the activities leading to the request for the establishment of an airspace restriction or reservation are in fact valid and justify such action;
- b) determine the minimum needs, in terms of space and time and the conditions of use, required to confine the activities so that potential hazards and disruptions to other users of the airspace are minimized or avoided;
- c) keep established airspace restrictions and/or reservations under frequent review in order to determine whether they are still required or may be abandoned when their need has ceased to exist, or whether modification in the light of changed requirements may be necessary.

3.3.1.4 With respect to a) above, one important aspect is the determination of how a request can best be met with the least interference to other users of the airspace. In many cases, experience has shown that requests have led to restrictions of the airspace when in fact the same purpose could have been achieved by an airspace reservation. If appropriate co-ordination had been effected between all parties concerned, granting an airspace reservation versus an airspace restriction would have resulted in significantly less detrimental effects on other users of the airspace in question.

3.3.2 Types of restrictions

3.3.2.1 Airspace restrictions can take the following form:

- a) danger area; or
- b) restricted area; or
- c) prohibited area.

3.3.2.2 According to their definitions, a danger area implies the least degree of restriction, while the prohibited area constitutes its most stringent form. It should also be noted, however, that this definition is applied only with respect to airspace which is situated over the territory of a State. In areas where no sovereign rights are exercised (e.g. over the high seas) *only danger areas* may be established by that body responsible for the activities causing their establishment.

3.3.2.3 The establishment of a danger area by a State over its territory is justified when the activity in that area is of such a nature that the risk involved requires non-participating aircraft to be aware of the risk. Since, in all cases, it is mandatory that the reason causing the establishment of an airspace restriction be given in its publication, it remains then at the discretion of the pilot to decide

whether or not he can face the risk with a reasonable degree of certainty that it will not have serious consequences for his flight.

3.3.2.4 Over the high seas, regardless of the risk involved, only danger areas can be established. Those who initiate danger area restrictions over the high seas are under an increased moral obligation to judge whether establishment of the danger area is unavoidable and if it is, to give full details on the intended activities therein. It would also appear that activities exceeding a certain risk level should not be conducted in such airspace and that other methods of achieving the desired objective, such as temporary airspace reservations, should be applied.

3.3.2.5 Restricted areas are generally established when the risk level involved in the activities conducted within the area is such that it can no longer be left to the discretion of individual pilots whether or not they want to expose themselves to such risk. In many cases the activities within a restricted area are not permanently present, it is therefore of particular importance that the times when these areas are actually required be closely surveyed and monitored.

3.3.2.6 The establishment of prohibited areas should be subject to particularly stringent requirements because the use of that portion of the airspace encompassed by the prohibited area is completely forbidden to aircraft. It has therefore become general practice to establish such areas only to protect important State installations, critical industrial complexes whose damage as a result of an aircraft accident could assume catastrophic proportions (atomic power plants, sensitive chemical complexes) or especially sensitive installations which are essential for the national security.

3.3.3 Airspace reservations

3.3.3.1 It is generally accepted practice that airspace reservations should only be applied during limited periods of time and should be abolished as soon as the activity having caused their establishment ceases. In addition, establishment of airspace reservations is governed much more by ATS considerations than is the case with airspace restrictions. In fact, airspace reservations should be coordinated primarily with the ATS units directly concerned

because they will be in the best position to propose and develop the procedural means required to put the reservation into effect.

3.3.3.2 In general, there exist two types of airspace reservations — namely, those which are established in a fixed relation to defined areas on the surface of the earth and those which are “mobile” because they follow activities which move in relation to the surface. Fixed airspace reservations generally cover specific flying or other events which are restricted to a specific area (military exercises, flying displays, etc.) while mobile airspace reservations are used to cover activities such as aerial refuelling, en-route mass formation flights, etc. For both types of reservations it is, however, essential that, depending on the activities conducted therein, adequate buffer areas be established around the reserved areas in order to ensure that ATS can provide an adequate margin of safety between non-participating aircraft and the activity concerned.

3.3.3.3 While it is recognized that there may exist legitimate reasons for establishment of airspace reservations, experience also seems to indicate that, once established, their existence is maintained long after the conditions having caused their creation have ceased to exist. It is therefore important that such airspaces be critically reviewed by States, especially with regard to maintaining a reasonable balance between the purpose to be achieved by their creation and the appreciable additional workload and interference they impose on flight crews in the conduct of their flight.

3.3.4 Special designated airspace

In a number of cases, States have found it necessary to establish special portions of designated airspace where aircraft, when operating therein, are required to comply with procedures additional to those resulting from normal provision of ATS (mainly special identification and/or reporting procedures). Such areas are designated by a variety of names, i.e. Air Defence Identification Zone (ADIZ) being one of the more common ones, but they all have in common the understanding that non-compliance by aircraft with the imposed provisions generally result in prompt retaliatory action (interception, forced landing, etc.).

Appendix A

Illustrations of Types of Airspace Configurations

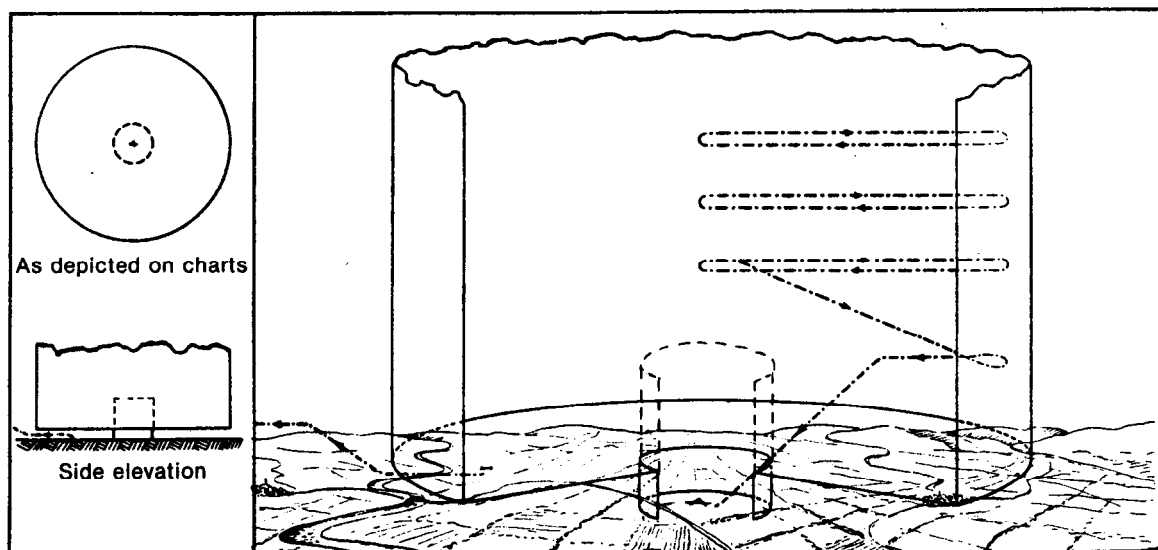

Figure A-1

1. When the provision of ATC service to IFR flights is limited to traffic arriving at and departing from an aerodrome used in instrument meteorological conditions (IMC), a control zone encompassing the flight path of the IFR traffic to be protected must be established. Since a control zone extends upwards from the surface of the earth and the provision of control therein will of necessity entail the imposition of certain restrictions on VFR flights operating within the control zone, it is essential that its lateral extent be kept to the minimum. However, in accordance with Annex 11, 2.7.5.2, the lateral limits of the control zone should not be less than 9.3 km (5 NM) from the centre of the aerodrome concerned, in the directions from which approaches may be made.
2. To keep the lateral limits of a control zone to a minimum, thereby enabling the maximum number of VFR operations to be conducted outside it, the control zone is invariably supplemented by additional controlled airspace normally in the form of a terminal control area (TMA), the lower limit of which, as may be noted in Annex 11, 2.7.3.2, must be established at a height of not less than 200 m (700 ft) above the ground or water.
3. Figure A-1 illustrates a simple combination of a control zone and a TMA which should be used unless problems due to the proximity of other controlled airspaces or obstructions dictate otherwise.
4. Where it appears desirable to increase the airspace within which special VFR flights may be authorized, the control zone may be extended upward so as to protrude into the TMA up to a specified limit.
5. When meteorological conditions do not permit a VFR flight to be conducted in a TMA or control zone, such flight may, within the meteorological conditions prescribed in Annex 2 — *Rules of the Air*, be operated below the TMA or, subject to special ATC authorization into, within or out of the control zone.

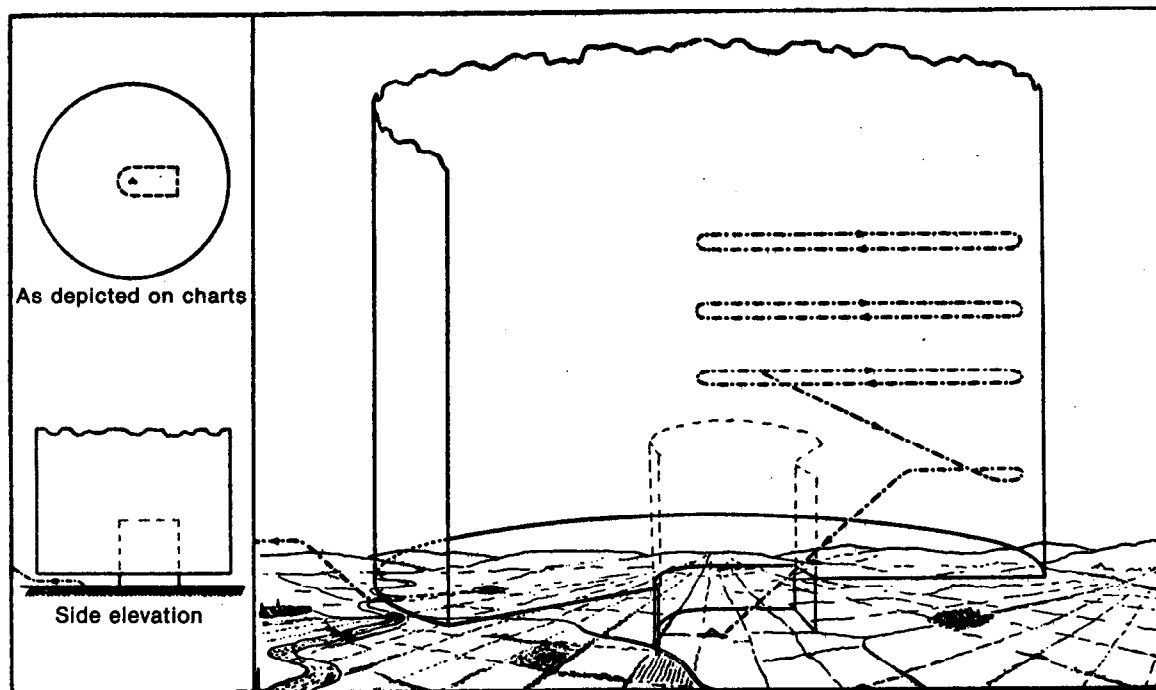

Figure A-2

1. Figure A-2 is similar to Figure A-1 except that the lateral limits of the control zone are not shown circular in shape but are extended to at least 9.3 km (5 NM) only in the direction of approach when circumstances preclude its extension to that distance in all directions.

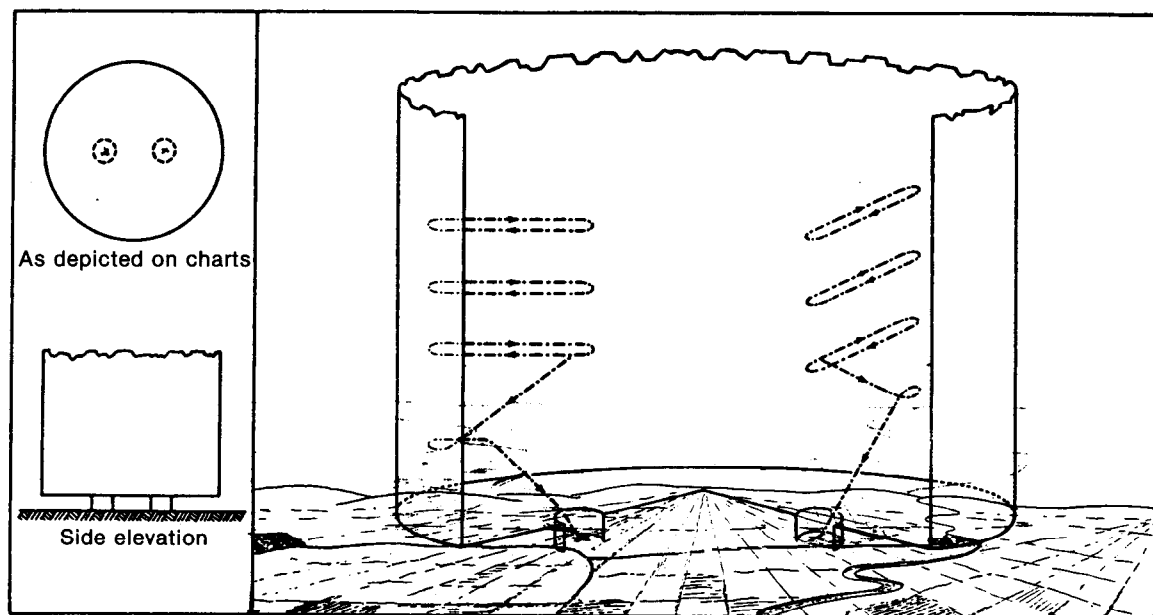

Figure A-3

1. Where two (or more) control zones are located close together and it is operationally undesirable to supplement each with a separate TMA, the control zones should be supplemented by one common TMA.
2. Figure A-3 shows a combination of two control zones and one TMA centred half-way between them. The TMA can, however, take any other shape as long as it encompasses the airspace required by IFR flights to be protected, always bearing in mind that it should also permit VFR operations conducted outside its limits and not bound for aerodromes which it serves.

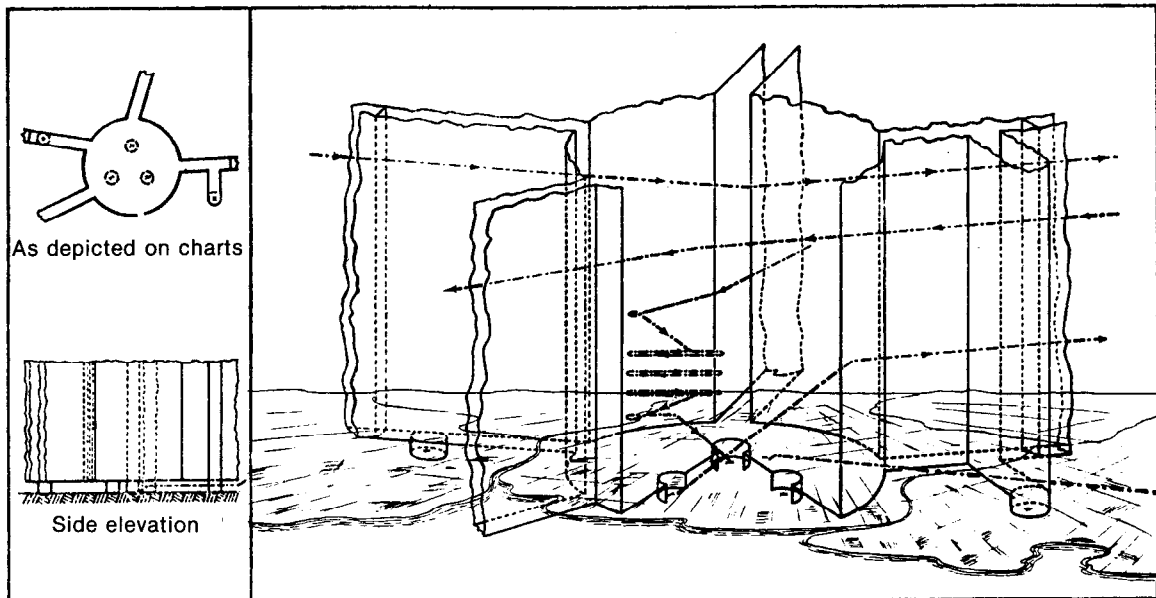

Figure A-4

1. Figure A-4 depicts a typical organization of airspace into control zones and control areas of specific types (i.e. TMAs and airways) to meet the minimum requirements of IFR traffic during en-route, approach and departure phases of flight. As indicated, the TMA together with the airways extending therefrom, forms one homogeneous control area.
2. It is to be noted that whereas the control zones in the centre of the diagram are shown supplemented by a TMA, the control zone at the left extremity of the diagram is shown supplemented by an airway because the establishment of a TMA is not always warranted.

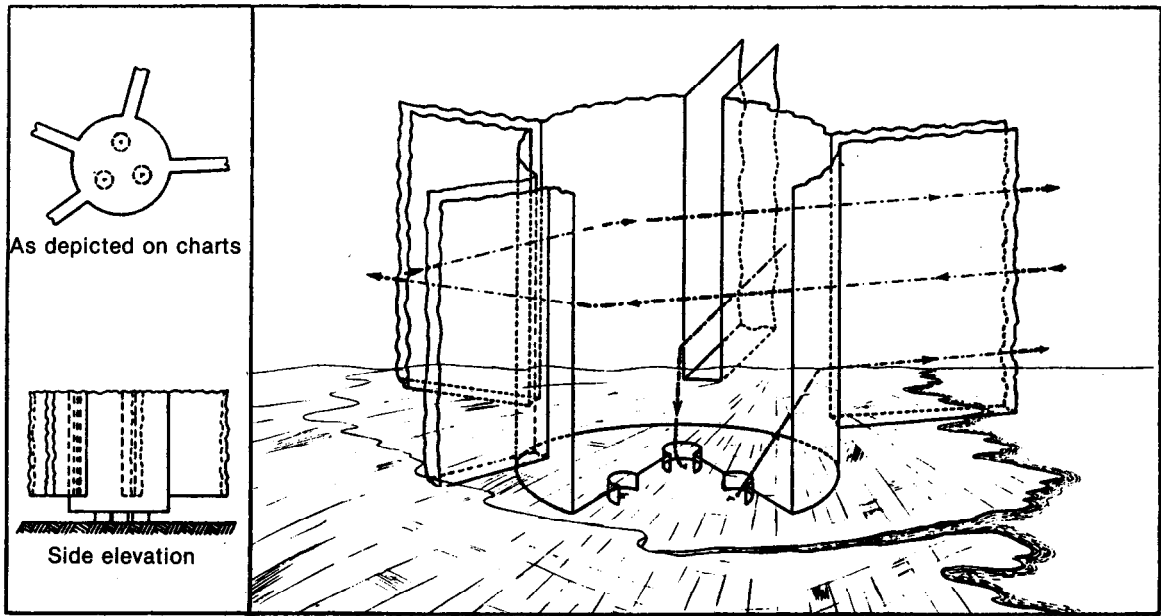

Figure A-5

1. Figure A-5 depicts a similar organization of airspace as Figure A-4, except that the lower limit of the airways has been established at a relatively high level, to that of the TMA, in order to give more freedom for the operation of VFR flight below the airways.

However, in this case it is necessary to complement the airways with TMAs in the vicinity of aerodromes used for IFR operations, in order that the size of the control zones may be kept to the minimum.

Chapter 4

ATS Routes

4.1 INTRODUCTION

4.1.1 Ideally, aircraft want to fly on the most direct route between their points of departure and their destination because the medium in which aircraft operate makes this possible, except when severe weather phenomena are encountered. However, because of the many conflicting demands made on the use of airspace by its many different users and because of environmental and security considerations, it is frequently not possible to fly the most direct route. Therefore it is necessary to find a reasonable compromise between this desirable objective and reality.

4.1.2 A further point is that, as soon as any degree of control is exercised over air traffic aircraft (and this applies to all types), it is inevitable that it must be channelled into a defined pattern whose extent and complexity must not exceed the intellectual and physical capabilities of the person or persons charged with controlling such traffic. Control must be possible with a mental and physical effort, as far as presentation, analysis and resolution of conflicts is concerned, which can be sustained over prolonged periods of time, since otherwise the continuity in control assured by one person is lost. It is therefore essential that the various individual intentions of those participants making up the traffic are presented in such a manner that they can be related to other, possibly conflicting intentions.

4.1.3 In short, large amounts of air traffic are generally only manageable if they follow pre-established patterns which are arranged not only to facilitate the detection of possible conflicting intentions at an early stage, but which also lend themselves to resolution of such conflicts. At the same time, these pre-established patterns must also provide for the retention of the most direct routes for the majority of air traffic, if they are not to conflict with the need for economy and efficiency of flight operations.

4.1.4 Experience gained in areas where large amounts of air traffic are handled has shown that the most satisfactory manner to meet the general considerations mentioned above is by way of an air traffic services (ATS) route network.

4.2 ESTABLISHMENT OF AN ATS ROUTE NETWORK

4.2.1 The establishment of an actual ATS route network follows, in most cases, an approximate pattern outlined below:

- a) operators identify their actual and anticipated requirements for routes between those aerodromes which they use;
- b) the sometimes widely diverging demands of individual operators are then consolidated into a reasonably coherent pattern of route requirements;
- c) these requirements are then measured against other demands made on the airspace traversed by these routes (military areas, avoidance of overflying sensitive installations on the ground, etc.) and alternative proposals for the exact alignment of individual routes are developed;
- d) these alternatives are then presented to and negotiated with the operators concerned until a reasonable compromise is achieved;
- e) in the comparatively few cases where the offers which can be made to operators are found to be unacceptable, it should be agreed that the original requirement should be retained for further consideration by all parties concerned until such time as more favourable circumstances permit an alignment which comes reasonably close to that requested by operators.

4.2.2 Experience has shown that adoption of the method described above has generally produced satisfactory results, especially as regards meeting those demands by operators which could not be initially met.

4.2.3 The establishment of a detailed ATS route network can follow two distinct patterns depending on the composition of the air traffic it is intended to serve. In those cases where national operations constitute the bulk of the traffic which is to be accommodated, States should give priority to satisfying these needs. However, adequate arrangements should be made to meet the needs of international operations through appropriate trunk routes and

development of these trunk routes must be co-ordinated on at least a regional basis. Where international operations constitute the majority of the traffic, establishment of an ATS route network needs to be undertaken from the outset on at least a regional basis.

4.2.4 From this it follows that, to a lesser or greater extent, isolated action by States in developing an ATS route network is only possible with respect to ATS routes serving strictly national purposes since such action will, in most cases, have direct and noticeable effects on the traffic flow beyond the area of responsibility of the State concerned. There is evidence available showing that changes made to ATS routes in one limited area can affect air traffic for a considerable distance and traffic which never even intends to operate into the area where the change was made.

4.2.5 Taking the above into account, it would appear that the detailed establishment or review of individual ATS routes, forming the ATS route network, should proceed along the following lines:

- a) first establish or review the main trunk routes, serving the major traffic flow within a given area as well as those extending beyond that area;
- b) establish or review those routes required to provide access to these trunk routes from and to locations not directly served by them;
- c) establish or review those supplementary routes required to accommodate secondary traffic flows or which are required to alleviate the traffic load on the major trunk routes;
- d) establish or review those routes of a more local nature which are required to satisfy either specific national needs or those of a specific user group (e.g. helicopter routes, visual flight rules (VFR) routes, military low-level routes, night flying, etc.) and determine if these local routes need to be integrated into the over-all route network.

4.2.6 Once the route network has been established or reviewed in accordance with the above, the detailed ATS route network should be reviewed as a whole to evaluate its coherence. Changes to the network should be made only after they have been co-ordinated with all parties concerned.

4.2.7 The majority of the ATS routes so established will be permanently available; however, there will be cases:

- a) when routes are required only for specific periods of the year (seasonal routes) in order to accommodate transit traffic during the holiday season; or

- b) where specific routes can be made available only during weekends because they traverse areas which, during the week, are reserved for other activities; or
- c) where routes whose use depends on special co-ordination procedures can only be effected on an *ad hoc* basis for the specific flights involved and depending on the circumstances as they prevail at that time.

4.2.8 Such non-permanent routes should also be included in the ATS route network, however with a clear indication of the limitations imposed on their use. Such an indication will then serve as a reminder that these routes should be reviewed at frequent intervals with a view to changing their status whenever the use made of them requires.

4.2.9 ATS routes over the high seas should be established only if traffic density warrants a channelling of air traffic in order to ensure its safety and only for such times when traffic density justifies their establishment. In addition, since flight operations over the high seas are more dependent on prevailing meteorological conditions (especially winds aloft) with respect to specific routing, and thus their economy, than is the case for shorter routes over land, it is essential that this be taken into account in the route alignment. Therefore, frequent adjustments should be made, either on a daily basis, as it is now done in the case of the North Atlantic route structure, or at such intervals as are required to take account of significant changes in the operating environment.

4.2.10 The status given to individual ATS routes, either as controlled ATS routes (generally in the form of airways) or as advisory routes or as uncontrolled routes, is primarily determined by the amount and type of traffic which is using the route as well as other relevant factors (see also Part I, Section 2, Chapter 3).

4.2.11 After the alignment and status of the ATS routes have been established or reviewed, it will be necessary to determine the use of flight levels on each of those routes which are to be established as controlled ATS routes. To this extent a series of flight levels are prescribed (normally "ODD" and "EVEN") which should be used in relation to the direction of flight on the route concerned. The principles governing such arrangements of flight levels include the following considerations:

- a) the majority of air traffic operating along a controlled ATS route or portion thereof, should, while in level flight, be permitted to remain at its assigned flight level without a need for changing levels simply because the orientation of the route in relation to compass direction changes;

b) at intersections of more than two controlled ATS routes, the likelihood that aircraft, operating on any of these routes and approaching the intersection, find themselves at the same level is kept to a minimum, thus avoiding the need for systematic control interventions in order to restore adequate separation between them.

4.2.12 Experience has shown that, in the case of more complex ATS route networks (e.g. European (EUR) region) this latter objective can only be achieved if the assignment of flight levels on certain routes is reversed at certain points along the route, depending on the situation at different intersections affecting the route in question. In this case, it is important that a change in flight level be established at a location well away from a flight information region (FIR) or control area (CTA) boundary or a transfer of control point (if different from the boundary) or at such a location where traffic along the route is least dense, thus permitting the change in level without undue difficulties to either the aircraft or ATS.

4.2.13 On ATS routes carrying a particularly high load of traffic, it may be advisable to establish one-way routings for each direction of flight between the points determining the terminals of such routes. In this case consecutive flight levels may be used on each of the two one-way routes, except when this is not feasible for the reasons stated in 4.2.11 b) above.

4.2.14 The world-wide designation of ATS routes is governed, in general, by provisions contained in Annex 11, Appendix 1. There are, however, a number of aspects involved in this matter which need more detailed consideration. These are:

- a) regard for flight planning and description of the route of flight required for air traffic control (ATC) clearances;
- b) avoidance of unnecessary complications in the co-ordination involved in the assignment of designators;
- c) taking into account the effects of the use of automation.

4.2.15 With respect to flight planning and ATC clearances, the system, used to assign designators to individual ATS routes within an ATS route network, should be arranged primarily so that the large number of repetitive air transport operations (scheduled and non-scheduled commercial flights, certain routine military operations) are able to indicate, in their flight planning, the route of flight with the least number of designators. Fewer designators also permit ATC to keep clearances short and concise and to clear such flights with the least amount of effort. In addition, different designators, which in air-ground communications could be mistaken for each other,

should be assigned so that, even when they are misunderstood, the error becomes obvious immediately by the difference in location of their assignment. In this respect account should also be taken of differences in pronunciation by pilots with different mother tongues.

4.2.16 In order to avoid duplication of designators, it will be necessary to co-ordinate their assignment on at least a regional basis. It is essential that the method chosen for doing this is as simple as possible, does not require excessive co-ordination and is done with the assistance of the regional office of ICAO concerned. It must also provide for ample capacity to accommodate future requirements for designators without requiring a change of the system itself.

4.2.17 Finally, the assignment of designators should be made so that changes to individual designators are kept to a minimum. This consideration is particularly important in those cases where ATC units providing service along the routes in question are using automatic ATC equipment, primarily because experience has shown that modifications to the computer programmes introduce considerable delays in bringing the changed designators into effect (see also Part II, Section 2, Chapter 9).

4.3 ESTABLISHMENT OF SIGNIFICANT POINTS

4.3.1 Significant points along ATS routes and/or in terminal control areas (TMAs) are normally established at those geographical locations where an event in the conduct of a flight takes place which is either significant to the pilot or to ATS or to both, i.e. a change in the alignment of an ATS route or of a routing in a TMA, an intersection of the centre lines of two or more ATS routes, a transfer of control point, etc. In many cases such points are also marked by the site of a ground-based radio aid to navigation (see Chapter 5 below) or with reference to navigational guidance derived from one or more such aids (intersection of two radials from different VHF omnidirectional radio ranges (VORs) or a point on a VOR radial determined by its distance from that VOR by means of the associated distance measuring equipment (DME)). In other cases, such points are established by reference to geographical co-ordinates only and navigation to and from these points will be made by reference to area coverage-type navigation aids (e.g. OMEGA) or by the use of self-contained navigation means (e.g. inertial navigation system

(INS)). In this case they are frequently referred to as "way-points".

4.3.2 As already mentioned, significant points can be sub-divided into four types according to the operational purpose they serve. They are:

- a) those points which are of interest to the pilot only in the conduct of his navigation, i.e. a change in the alignment of a route, change-over between successive radio navigation aids, etc.;
- b) those points which are of interest to both the pilot and ATS because they:
 - 1) define the intentions of pilots as to the route of flight to be followed (in flight plans); or
 - 2) permit ATS to provide proper service to aircraft (obtain position reports, begin or terminate service rendered to an aircraft); or
 - 3) allow ATC to define changes to the route of flight when required by the over-all traffic situation (re-clearance of flights as to route and/or level between specified points, etc.);
- c) those points which are of interest to both the pilot and ATS but only for limited periods of time and specific phases of flight. These points normally do not form part of the data exchanged between ATS units and are usually used only to define specific flight paths to be followed when *ad hoc* clearances are issued by ATC (e.g. points along routings in a TMA, points where an aircraft can expect to be cleared to change levels or where a clearance to conduct the flight in a specific manner begins, or ends);
- d) those which are of interest to ATS only such as transfer of communication and/or control points, exit and entry points into specified portions of controlled airspace, etc. Generally, these points are established only for use between two adjacent ATC units. Information regarding the flight progress in relation to these points will be confined to the two units in question.

4.3.3 The designation of such points is covered, in general terms, in Annex 11, Appendix 2. Much of what has already been said above, in 4.2.3.8 to 4.2.3.11, on some of the supplementary aspects regarding the designation of ATS routes also applies to establishment of significant points. In fact, world-wide experience with the administration of designators for significant points not marked by the site of a radio navigation aid (name codes) seems to indicate that establishment of significant points should be reserved for those significant points mentioned in 4.3.2 b) above, while the designation of all other points, mentioned in 4.3.2 a) and c) should be kept to local or, if necessary, regional arrangements. This limitation in application to

cases mentioned in 4.3.2 b) above appears possible in view of the fact that the original requirement stipulated for the uniqueness of such name codes on a world-wide scale no longer seems valid.

4.4 ROUTINGS IN TERMINAL CONTROL AREAS

4.4.1 In accordance with the relevant provisions in Annex 11, 3.7.1.2, standard departure (SID) and standard arrival (STAR) routes may be established, when required, to facilitate:

- a) the maintenance of a safe, orderly and expeditious flow of air traffic;
- b) the description of the route and procedures in ATC clearances.

4.4.2 From this it follows that such routings in TMAs will normally be required only at the busier aerodromes where the initial departure and/or arrival routing may be complex in view of the use made of runways and/or the variable relationship between the departure and arrival patterns used under different meteorological and/or traffic conditions.

4.4.3 Once the requirement for such routes has been determined it should be ensured that their alignment is such that flight along them does not require excessive navigational skill on the part of pilots nor should they put the aircraft into a state which approaches its minimum safe operation with regard to speed and/or changes of direction. Such considerations are essential because, when using these routes, pilots find themselves in a critical phase of their flight and the cockpit workload is already heavy after take-off or when preparing for a landing. Material relating to the establishment of standard departure and arrival routes and associated procedures is given in Appendix A to this chapter.

4.4.4 The need to take into account noise abatement at certain aerodromes has become an important issue. Appropriate SIDs and STARs should be reviewed in the context of special noise abatement procedures and/or manoeuvres to ensure that they are fully integrated and constitute a coherent operational entity serving both purposes. In addition, noise abatement procedures should not jeopardize the safe and efficient conduct of the aircraft flight phase in question.

4.4.5 The question of designation of SIDs and STARs is covered in Annex 11, Appendix 3. However, in selecting designators in accordance with these provisions, care must be taken to ensure that no confusion will arise in their practical use in voice communications because of close

similarities between different designators. It may also be necessary to consider pronunciation problems caused by the fact that pilots with different mother tongues may pronounce designators differently in their voice communications with the ATC unit assigning a SID or STAR.

Appendix A

Material relating to the establishment of standard departure and arrival routes and associated procedures

1. General

1.1 Standard departure and arrival routes should:

- a) segregate traffic operating along different routes, and such traffic from traffic in holding patterns;
- b) provide for adequate terrain clearance (see PANS-OPS (Doc 8168), Volume II);
- c) be compatible with established radiocommunication failure procedures;
- d) take account of noise abatement procedures;
- e) provide for the shortest practical tracks;
- f) provide, to the extent possible, for uninterrupted climb or descent to operationally advantageous levels with a minimum of restrictions;
- g) be compatible with the performance and navigation capabilities of aircraft;
- h) if possible, be designed so as to derive maximum economic and operational benefit from high performance and advanced navigation capabilities of aircraft.

1.2 The routes should involve a minimum of air-ground radiocommunications and reduce as much as possible cockpit and ATC workload.

1.3 Standard departure and arrival routes should normally be completely contained within controlled airspace.

1.4 For routes requiring navigation with reference to ground-based radio navigation facilities, the following should apply:

- a) they should relate to published facilities only;
- b) the number of facilities should be kept to the minimum necessary for navigation along the route and for compliance with the procedure;
- c) they should require navigational reference to no more than two facilities at the same time.

1.5 The routes should normally be designed for use by aircraft operating in accordance with IFR. Separate routes designed for use by controlled flights operating in accordance with VFR may be established.

1.6 The number of standard departure and arrival routes to be established at an aerodrome should be kept to a minimum.

2. Standard departure and arrival routes — instrument

2.1 Standard instrument departure routes should link the aerodrome or a specified runway of the aerodrome with a specified significant point at which the en-route phase of a flight along a designated ATS route can be commenced.

2.2 Standard instrument arrival routes should permit transition from the en-route phase to the approach phase by linking a significant point on an ATS route with a point near the aerodrome from which:

- a) a published standard instrument approach procedure can be commenced; or
- b) the final part of a published instrument approach procedure can be carried out; or
- c) a visual approach to a non-instrument runway can be initiated; or
- d) the aerodrome traffic circuit can be joined.

2.3 Each standard instrument departure and arrival route should be established and published as an integral route. Any deviation of a permanent nature should be published as a separate route.

2.4 Standard instrument departure and arrival routes should be designed so as to permit aircraft to navigate along the routes without radar vectoring. In high density terminal areas, where complex traffic flows prevail due to the number of aerodromes and runways, radar procedures may be used to vector aircraft to or from a significant point on a published standard departure or arrival route, provided that:

a) procedures are published which specify the action to be taken by vectored aircraft in the event of radiocommunication failure, and

b) adequate ATC procedures are established which ensure the safety of air traffic in the event of radar failure.

2.5 The routes should identify the significant points where:

a) a departure route terminates or an arrival route begins;

b) the specified track changes;

c) any level or speed restrictions apply or no longer apply.

2.6 Where the route requires a specified track to be followed, adequate navigational guidance should be provided.

2.7 Significant points of standard instrument departure and arrival routes requiring navigation with reference to ground-based radio navigation facilities, particularly points where a change of track is specified, should, whenever possible, be established at positions marked by the site of a radio navigation facility, preferably a VHF aid. When this is not possible, the significant points should be established at positions defined by:

a) VOR/DME; or

b) VOR/DME and a VOR radial; or

c) intersections of VOR radials.

The use of NDB bearings should be kept to a minimum, and fan markers should not be used.

2.8 Significant points established at positions defined by VOR/DME should relate to a VOR/DME facility defining the track to be flown.

2.9 The radio navigation facility to be used for initial track guidance on a standard instrument departure route should be identifiable in the aircraft prior to take-off.

2.10 Taking into account that the period immediately after take-off is one of high cockpit workload, the first significant point of a standard instrument departure route which requires reference to a radio navigation facility should, if possible, be established at a distance of at least 2 NM from the end of the runway.

2.11 Level restrictions, if any, should be expressed in terms of minimum and/or maximum levels at which significant points are to be crossed.

2.12 The designation of significant points as reporting points (compulsory or on request) should be kept to a minimum.

2.13 Standard instrument departure and arrival routes should be established in consultation with the representatives of the users and other parties concerned.

3. Standard departure and arrival routes — visual

3.1 Visual departure routes should link the aerodrome or a specified runway of the aerodrome with a specified significant point at which the en-route phase of a flight can be commenced.

3.2 Visual arrival routes should link a specified significant point where the en-route phase of a flight is terminated with a point where the aerodrome traffic circuit can be joined.

3.3 Significant points defining visual routes should be established at geographical locations which can be readily identified by visual reference to prominent landmarks. The locations of radio navigation aids may also be used as significant points, if practical.

Chapter 5

Alignment of ATS Routes

5.1 INTRODUCTION

5.1.1 The alignment of air traffic services (ATS) routes and their integration into a coherent ATS route network, as discussed in Chapter 4 of this section, is largely determined by the demands made on the use of airspace by its different users. However, national security, environmental and other considerations also play a part in determining the alignment of ATS routes. There is therefore a need to ensure that routes so established can be followed by aircraft under all conditions and that for this reason, suitable navigational guidance defining the centre lines of each of the established routes needs to be provided.

5.1.2 For areas over land and for comparatively short routes, such navigation guidance should be provided by ground-based, point source navigation aids. ICAO has established a policy that, wherever possible, the aid chosen should be a VHF omni-directional radio range, supplemented by distance measuring equipment (DME) as required. In many cases, due to historical developments, non-directional radio beacons (NDB) are also in use, even though their operational performance offers distinct disadvantages when compared with that of the VHF omni-directional radio range (VOR) or VOR/DME (see Part III, Section 1, Chapters 2 and 3).

5.1.3 Navigational guidance required over the high seas is generally provided from two different sources:

- a) ground-based long-range navigation systems providing an area-type coverage (LORAN-C, OMEGA, etc.);
- b) self-contained navigation aids which are practically independent from externally derived navigation inputs (INS).

While it is unnecessary in this chapter to discuss the use of long-range or self-contained aids for navigation purposes, it will nevertheless be necessary to discuss their role in the establishment and alignment of ATS route network systems over the high seas and the separation upon which such systems are based.

5.1.4 The manner in which navigational guidance is obtained by pilots has one very significant effect on the definition of ATS routes, both over land and over the high seas. It concerns the width and the spacing between parallel, converging or diverging routes. The reason for this concern is that certain allowances must be made in respect of the navigation accuracy of aircraft, be it because of the accuracy inherent in the system or to account for pilot reaction time and/or the response characteristics and capabilities of aircraft to correct action in case of noticed deviations or, last but not least, to compensate for the effects of wind on the flight path of the aircraft.

5.1.5 In the case of point-source aids, it should also be noted that the accuracy of navigation which can be achieved by aircraft in the horizontal plane is directly proportional to their distance from the site of the aid in question, i.e. the greater the distance, the bigger the lateral displacement from the ideal line. It should be noted, however, that when this displacement is expressed in angular terms it is independent of the distance involved. In the case of area-type navigation systems, accuracy can be expressed in constant terms which apply throughout the systems area of use, except in those cases where certain local phenomena (surface and/or electrical conditions in the atmosphere) may influence the performance of the system in specified areas only. As to self-contained navigation systems, accuracy tends to deteriorate as a function of the length of time they are used — a condition which results in a cumulative error that grows fairly regularly until such time as it can be eliminated by updated navigational information obtained from external sources.

5.1.6 A further, relevant point of general concern is, that navigation aids supporting an ATS route network, and especially point-source aids, should be planned on a system-wide basis whereby each aid is used in an optimum manner. Since the ATS route network in many parts of the world requires planning on a larger than national scale (see Part I, Section 2, Chapter 4, 4.2) the same planning applies to the supporting navigation aids if duplication and/or waste of effort are to be avoided.

5.1.7 In addition, the system of navigation aids should provide flight crews with information to enable them to determine their position to maintain their planned or cleared track with the required accuracy and to effect corrections or changes needed to complete the flight.

5.1.8 The system of navigation aids should also meet a level of availability and performance reliability consistent with the requirement for safety and efficiency. In addition, the system should provide for reporting and transfer of control points commensurate with the justified needs of ATS units.

5.1.9 Account should also be taken of the fact that certain aircraft may be able to meet the navigation and ATS needs during their flight by reference to navigation aids other than those specifically provided for this purpose, i.e. INS instead of VOR/DME. This fact should be taken into account, provided the accuracy obtained by such alternative means is compatible with that obtained by using the primary means. Furthermore, within a given zone where specific groups of users have been authorized by the competent authorities to use special aids for navigation (e.g. tactical air navigation aid (TACAN)), the respective ground facilities should, if possible, be located and aligned so as to provide for full compatibility with that obtained from the primary system, especially within controlled airspace.

5.1.10 It should be realized that, because of the various factors (e.g. pilot reaction time, aircraft response time, wind conditions, inherent system performance), the overall degree of navigation accuracy will vary continuously within certain tolerances. Therefore accuracy can be defined only in terms which have been found to be reasonable with regard to both navigation and the area wherein it is practised. It would seem, therefore, that such terms cannot be established other than by practical experience and, once determined for a specific environment, they cannot be indiscriminately used elsewhere. The point which needs to be kept in mind is that navigation is a pragmatic art and that the application of conclusions drawn from it should be dictated more by practical than by hypothetical or theoretical considerations.

5.2 ALIGNMENT OF ATS ROUTES BASED ON VOR

5.2.1 From the above, it follows that, apart from providing adequate track guidance along an ATS route (i.e. that aircraft can operate along the centre line of a route

with reference to navigation signals provided by successive VORs), the main question to be resolved in relation to each route is its lateral dimension, i.e. the airspace which should be provided on either side of the centre line in order to ensure that aircraft do not find themselves in airspace where they are no longer ensured of the protection which they may expect while operating within the established limits of the route. This lateral protection applies particularly in the case of controlled ATS routes where the conditions of operation, and the associated level of protection while flying within the limits of the route, may be significantly different from those which prevail in the surrounding airspace.

5.2.2 It is therefore necessary to establish certain general criteria which should govern the establishment of ATS routes (and more so controlled ATS routes) and which should represent a consensus between providers (normally States through their ATS) and users. Experience, in areas where highly developed ATS route networks have been in existence for a long time, indicates that the following criteria are valid when considering alignment of ATS routes based on VOR:

- a) the planning of ATS routes should be done so that aircraft can, in 95 per cent of all occasions, remain within a specified lateral distance from the centre line of a VOR-defined ATS route:
 - 1) the most realistic method of determining this probability in relation to a navigation system based on VOR is the assessment of the total system error. The total system error of a VOR in the lateral plan is normally assumed to be ± 5 degrees;
 - 2) where, due to exceptional circumstances, it may be required to use a higher value than ± 5 degrees, the lateral limits of the affected ATS route or the permissible deviation from the intended flight track should be adjusted accordingly;

Note.— Annex 10, Volume I, Part I, Attachment C provides additional guidance.
- b) where it is planned to use values less than ± 5 degrees, in respect of specific ATS routes, it should be agreed between the States and the operators concerned that the lesser values can be demonstrated in routine operations. The use of such values also presupposes that the performance of the ground aid concerned, and the related airborne equipment, are subject to appropriate calibration and continued monitoring;
- c) the presentation of the ATS routes on maps and charts should be so that the use of such charts does not present undue difficulties or require an excessive amount of interpretation in practical operations.

5.2.3 The lateral width of an ATS route may vary depending on the distance between successive VORs used to provide track guidance (see Appendix A, 1 to this chapter). However, experience in those areas of the world where air traffic is dense has shown that, for the vast majority of cases, it is satisfactory to select one uniform value for the determination of the width of ATS routes. This value is ± 5 NM from the centre line, as defined by track guidance derived from successive VORs, which also meets the criterion mentioned in 5.2.2 c) above. A more sophisticated method of determining protection values for VOR-defined ATS routes is shown in Appendix A and has, as a rule, been reserved for application in those exceptional cases where either:

- a) airspace is at a premium because of conflicting demands and utmost economy in its use is therefore required; or
- b) the distance between successive VORs on an ATS route is excessive (Appendix A, 1 refers).

5.2.4 With regard to the spacing of parallel ATS routes defined by VORs (Appendix A, 2 refers) it is particularly important to keep in mind what has been said in 5.1.10 above regarding the need to remain practical and to take decisions only once all factors and assumptions having a bearing on this complex problem have been verified in routine operations.

5.2.5 A summary of the various considerations, relevant to the deployment of VOR and DME, in an ATS route network is shown in Appendix B. The general specifications regarding the publication of ATS routes and relevant supporting aids are shown in the *Aeronautical Information Services Manual* (Doc 8126). Specific guid-

ance regarding the promulgation of the nominal centre lines of VOR-defined ATS routes is shown in Appendix C.

5.3 ALIGNMENT OF ATS ROUTES OVER THE HIGH SEAS

5.3.1 As indicated in 5.1.3 above, ground-based, point-source navigation aids are normally not used over the high seas. This fact is due not only to the fact that such aids are not capable of providing coverage over long distances or where they do, they do not provide the required degree of accuracy, but mainly because these aids are not suitable for providing the area-type coverage required to define the variable tracks needed in such areas to keep operations economical (see Chapter 4, 4.2.9).

5.3.2 Because ATS routes over the high seas have to be kept flexible, their establishment is even more dictated by the need to ensure that the protected airspace on either side of the routes is such that the required safety level against risks of collision between aircraft is guaranteed (see Part II, Section 2, Chapters 3 and 4). In addition, responsibility for the provision of air navigation services over the high seas is normally shared between a number of States and generally based on regional air navigation agreements. In most of the cases involving smaller oceanic areas, i.e. the Mediterranean Sea, the North Sea, the Baltic Sea and the Black Sea, the methods used to establish an ATS route network over land areas based on VORs are applied because the length of the over-water portions of the ATS routes concerned are not excessive.

Appendix A

Protection Values for VOR-Defined ATS Routes

1. DETERMINATION OF PROTECTED AIRSPACE ALONG ATS ROUTES DEFINED BY VORs

Note 1.— The material of this section has not been derived by means of the conflict-risk/target level of safety method.

Note 2.— The word “containment” as used in this section is intended to indicate that the protected airspace provided will contain the traffic for 95 per cent of the total flying time (i.e. accumulated over all aircraft) for which the traffic operates along the route in question. Where, for example 95 per cent containment is provided, it is implicit that for 5 per cent of the total flying time traffic will be outside the protected airspace. It is not possible to quantify the maximum distance which such traffic is likely to deviate beyond the protected airspace.

1.1 For VOR-defined routes where radar is not used to assist aircraft in remaining within the protected airspace, the following guidance is provided. However, when the lateral deviations of aircraft are being controlled with the aid of radar monitoring, the size of the protected airspace required may be reduced, as indicated by practical experience gained in the airspace under consideration.

1.2 As a minimum, protection against activity in airspace adjacent to the routes should provide 95 per cent containment.

1.3 The work described in ICAO Circular 120 indicates that a VOR system performance based on the probability of 95 per cent containment would require the following protected airspace around the centre line of the route to allow for possible deviations:

- VOR routes with 93 km (50 NM) or less between VORs: ± 7.4 km (4 NM)
- VOR routes with up to 278 km (150 NM) between VORs: ± 7.4 km (4 NM) up to 46 km (25 NM) from the VOR then expanding protected airspace up to ± 11.1 km (6 NM) at 139 km (75 NM) from the VOR.

1.4 If the appropriate ATS authority considers that a better protection is required, e.g. because of the proximity of prohibited, restricted or danger areas, climb or descent paths of military aircraft, etc., it may decide that a higher level of containment should be provided. For delineating the protected airspace the following values should then be used:

- for segments with 93 km (50 NM) or less between VORs, use the values in line A of the table below
- for segments with more than 93 km (50 NM) and less than 278 km (150 NM) between the VORs use the values given in line A of the table up to 46 km (25 NM), then expand linearly to the value given in line B at 139 km (75 NM) from the VOR.

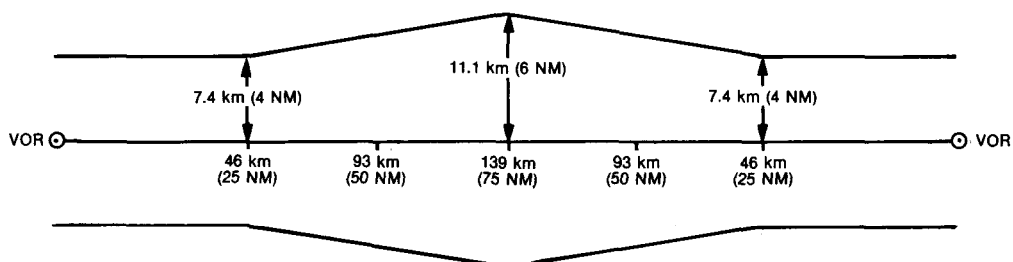

Figure 1

	Percentage containment					
	95	96	97	98	99	99.5
A (km)	±7.4	±7.4	±8.3	±9.3	±10.2	±11.1
(NM)	±4	±4	±4.5	±5	±5.5	±6
B (km)	±11.1	±11.1	±12.0	±12.0	±13.0	±15.7
(NM)	±6	±6	±6.5	±6.5	±7	±8.5

For example, the protected area for a route of 222 km (120 NM) between VORs and for which 99.5 per cent containment is required should have the shape as shown in Figure 2.

1.5 If two segments of a VOR-defined ATS route intersect at an angle of more than 25 degrees, additional protected airspace should be provided on the outside of the turn. This additional space is to act as a buffer for increased lateral displacement of aircraft, observed in practice, during changes of direction exceeding 25 degrees. The amount of airspace added varies with the angle of intersection. The greater the angle, the greater the additional airspace to be used.

Note.— It may be necessary, particularly in the case of sharp turns, to provide additional protected airspace on the inside of the turn, in order to contain aircraft which start their turn at a significant distance before the VOR.

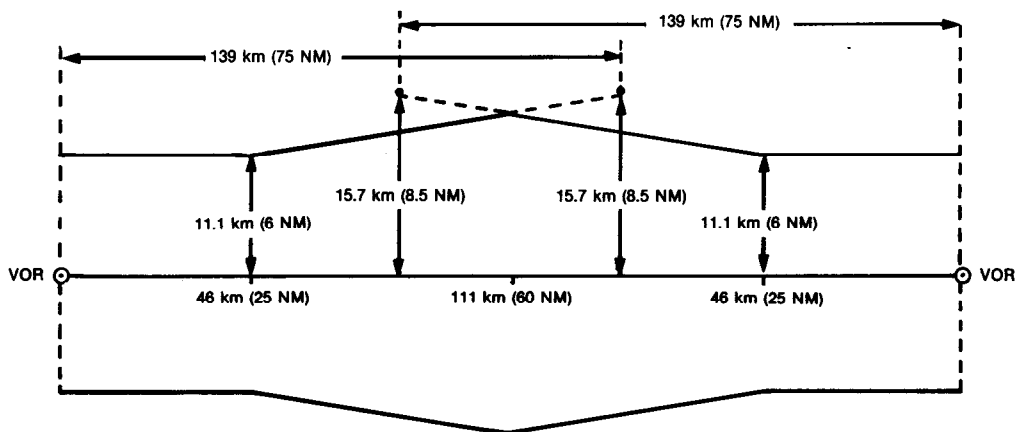

Figure 2

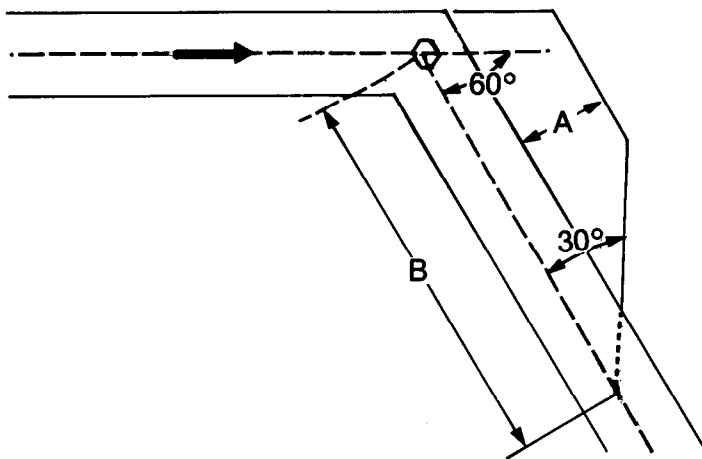

Figure 3

1.6 The following examples have been synthesized from the practices of two States which use templates to facilitate the diagramming of airspace for planning purposes. Design of the turning area templates took into account factors such as aircraft speed, bank angle in turns, probable wind velocity, position errors, pilot delays and an intercept angle of at least 30 degrees to achieve the new track, and provides at least 95 per cent containment.

1.7 A template was used to establish the additional airspace required to contain aircraft executing turns of 30, 45, 60, 75 and 90 degrees. The simplified figures below represent the outer limits of this airspace with the fairing curves removed to allow easy construction. In each case, the additional airspace is shown for aircraft flying in the direction of the large arrow. Where routes are used in both directions, the same additional airspace should be provided on the other outside boundary.

1.8 Figure 3 illustrates the application of two segments intersecting at a VOR, at an angle of 60 degrees.

1.9 Figure 4 illustrates the application for two segments meeting at a VOR intersection at an angle of 60 degrees beyond the point where boundary splay is required in order to comply with 1.3 and Figure 1.

1.10 The following table outlines the distances to be used in sample cases when providing additional protected

airspace for route segments at and below FL 450, intersecting at a VOR or meeting at a VOR intersection not more than 139 km (75 NM) from each VOR.

Note. — Refer to Figures 3 and 4.

<i>Angle of intersection</i>	30°	45°	60°	75°	90°
<i>VOR</i>					
*Distance "A" (km)	5	9	13	17	21
(NM)	3	5	7	9	11
*Distance "B" (km)	46	62	73	86	92
(NM)	25	34	40	46	50
<i>Intersection</i>					
*Distance "A" (km)	7	11	17	23	29
(NM)	4	6	9	13	16
*Distance "B" (km)	66	76	88	103	111
(NM)	36	41	48	56	60

* Distances are rounded up to the next whole kilometre/nautical mile.

Note. — For behaviour of aircraft at turns, see ICAO Circular 120, 4.4.

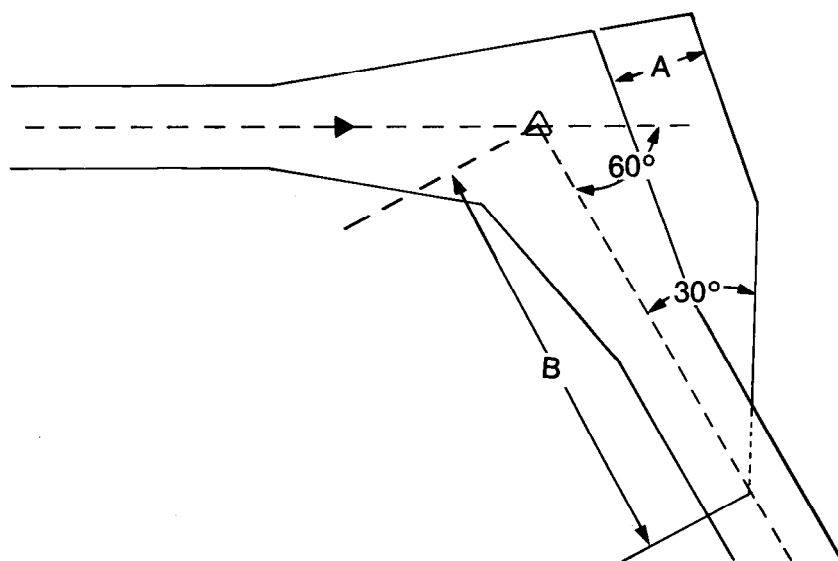

Figure 4

1.11 Measured data for routes longer than 278 km (150 NM) between VORs are not yet available. To determine protected airspace beyond 139 km (75 NM) from the VOR, the use of an angular value of the order of 5 degrees as representing the probable system performance would appear satisfactory. Figure 5 illustrates this application.

2. SPACING OF PARALLEL ROUTES DEFINED BY VORs

Note.— The material of this section has been derived from measured data using the conflict-risk/target level of safety method.

2.1 The collision risk calculation, performed with the data of the European study* indicates that, in the type of environment investigated, the distance between route centre lines (S in Figure 6) for distances between VORs of 278 km (150 NM) or less should normally be a minimum of:

- a) 33.3 km (18 NM) for parallel routes where the aircraft on the routes fly in opposite directions; and
- b) 30.6 km (16.5 NM) for parallel routes where the aircraft on the two routes fly in the same direction.

Note.— Two route segments are considered parallel when:

- they have about the same orientation, i.e. the angular difference does not exceed 10 degrees;
- they are not intersecting, i.e. another form of separation must exist at a defined distance from the intersection;

* The guidance material in this Appendix results from comprehensive studies, carried out in Europe in 1972 and the United States in 1978, which were in general agreement. Details of the European studies are contained in ICAO Circular 120 — *Methodology for the Derivation of Separation Minima Applied to the Spacing Between Parallel Tracks in ATS Route Structures.*

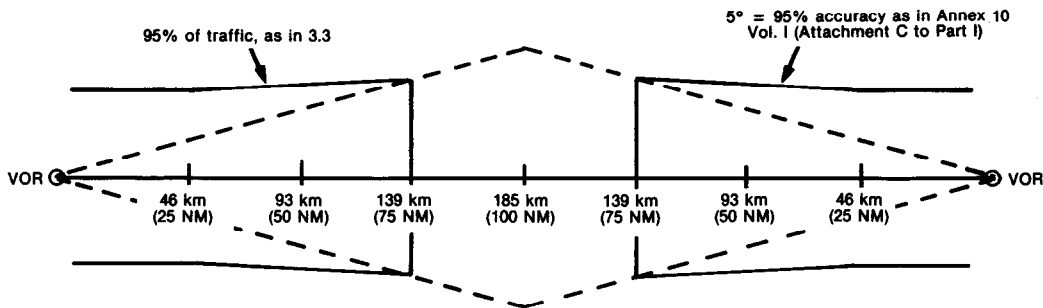

Figure 5

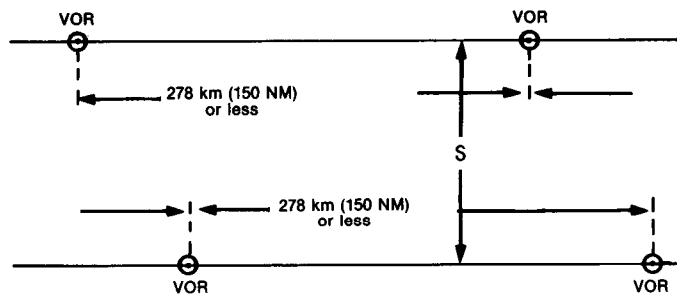

Figure 6

— traffic on each route is independent of traffic on the other route, i.e. it does not lead to restrictions on the other route.

2.2 This spacing of parallel routes assumes:

- a) aircraft may either during climb or descent or during level flight be at the same flight levels on the two routes;
- b) traffic densities of 25 000 to 50 000 flights per busy two-month period;
- c) VOR transmissions which are regularly flight checked in accordance with ICAO Doc 8071 — *Manual on Testing of Radio Navigation Aids* and have been found to be satisfactory in accordance with the procedures in that document for navigational purposes on the defined routes; and
- d) no real-time radar monitoring or control of the lateral deviations is exercised.

2.3 Preliminary work indicates that, in the circumstances described in a) to c) below, it may be possible to reduce the minimum distance between routes. However, the figures given have not been precisely calculated and in each case a detailed study of the particular circumstances is essential:

- a) if the aircraft on adjacent routes are not assigned the same flight levels, the distance between the routes may be reduced; the magnitude of the reduction will depend on the vertical separation between aircraft on the adjacent tracks and on the percentage of climbing and descending traffic, but is not likely to be more than 5.6 km (3 NM);
- b) if the traffic characteristics differ significantly from those contained in ICAO Circular 120, the minima contained in 2.1 may require adjustment. For example, for traffic densities of about 10 000 flights per busy two-month period a reduction of 900 to 1 850 m (0.5 to 1.0 NM) may be possible;
- c) the relative locations of the VORs defining the two tracks and the distance between the VORs will have an effect on the spacing, but this has not been quantified.

2.4 Application of radar monitoring and control of the lateral deviations of the aircraft may have a large effect on the minimum allowable distance between routes. Studies on the effect of radar monitoring indicate that:

— further work is necessary before a fully satisfactory mathematical model can be developed;

— any reduction of separation is closely related to:

- traffic (volume, characteristics);
- radar coverage and processing, availability of an automatic alarm;
- monitoring continuity;
- sector work-load; and
- radiotelephony quality.

According to these studies and taking into account the experience some States have accumulated over many years with parallel route systems under continuous radar control, it can be expected that a reduction to the order of 15 to 18.5 km (8 to 10 NM), but most probably not less than 13 km (7 NM), may be possible as long as radar monitoring work-load is not increased substantially by that reduction. Actual operations of such systems using reduced lateral spacing have shown that:

— it is very important to define and publish change-over points (see also 4);

— large turns should be avoided when possible; and

— where large turns cannot be avoided, required turn profiles should be defined for turns larger than 20 degrees.

Even where the probability of total radar failure is very small, procedures to cover that case should be considered.

3. SPACING OF ADJACENT VOR-DEFINED ROUTES THAT ARE NOT PARALLEL

Note 1.— The material of this section is intended to provide guidance for situations where non-intersecting VOR-defined routes are adjacent and have an angular difference exceeding 10 degrees.

Note 2.— The material of this section has not been derived by means of the conflict-risk/target level of safety method.

3.1 For adjacent non-intersecting VOR-defined routes that are not parallel, the conflict-risk/target level of safety method is not, at its present state of development, fully appropriate. For this reason use should be made of the material in 1.

3.2 The protected airspace between such routes should not be less than that which will provide, without overlap, the 99.5 per cent containment values given in the table in 1.4 (see example in Figure 7).

3.3 Where there is an angular difference of more than 25 degrees between route segments, additional protected airspace, as indicated in 1.5 to 1.10, should be provided.

4. CHANGE-OVER POINTS FOR VORs

4.1 When considering the establishment of points for change-over from one VOR to another for primary navigational guidance on VOR-defined ATS routes, States should bear in mind that:

- a) the establishment of change-over points should be made on the basis of performance of the VOR stations concerned, including an evaluation of the interference protection criteria. The process should be verified by flight checking (see Doc 8071, Volume I, Chapter 2);
- b) where frequency protection is critical, flight inspection should be undertaken at the highest altitudes to which the facility is protected.

4.2 Nothing in 4.1 should be interpreted as placing a restriction on the service ranges of VOR installations meeting the specifications in Annex 10, Volume I, Part I, 3.3.

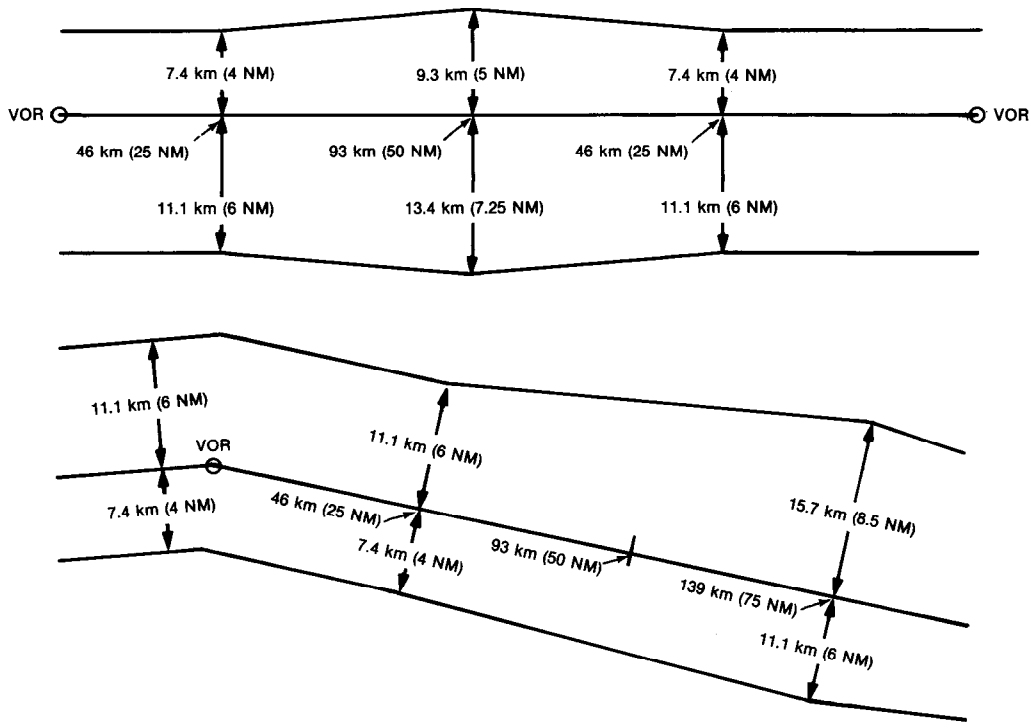

Figure 7

Appendix B

Criteria for the Deployment of VOR and DME

Note.— The material contained in this appendix is derived from satisfactory experience gained in the European (EUR) region.

1. EXPLANATION OF TERMS

In the deployment of radio navigation aids and related matters, the terms listed below are used with the following meaning:

a) *designated operational range or height*

The range or height to which an aid is needed operationally in order to provide a particular service and within which the facility is afforded frequency protection.

Note 1.— The designated value for range or height is determined in accordance with the criteria for the deployment of the aid in question.

Note 2.— The designated value for range or height forms the basis for the technical planning of aids.

b) *designated operational coverage*

The term designated operational coverage is used to refer to the combination of the designated operational range and the designated operational height (e.g. 200 NM/FL 500).

2. CRITERIA

2.1 Compatibility of different navigation systems

2.1.1 *Number 1 — Combination of several requirements:* Whenever possible, requirements (either civil, military or both) for en-route and/or terminal navigation guidance covering the same general area should be combined so that they can be met by the least number of individual facilities.

2.1.2 *Number 2 — Differences between international and national requirements for the same facility:* Where a specific VORTAC or VOR/DME is serving both international and national (civil and/or military) requirements

which are not identical as far as designated operational range and/or height are concerned, the higher of each of the respective values constitutes the combined requirement.

2.2 Over-all system use accuracy of VOR and DME

2.2.1 *Number 3 — Over-all system use accuracy:*

a) for VORs an over-all system use accuracy of $\pm 5^\circ$ should normally be used for planning purposes (see also the relevant paragraph in Annex 10, Volume I, Attachment C);

Note.— In specific cases improved accuracies are being obtained and are used for the alignment of the specific ATS routes.

b) for DMEs, co-located with an associated VOR in accordance with the applicable provisions of ICAO Annex 10, Volume I, Part I, the system use accuracy to be used for planning purposes regarding the configuration of ATS routes and related questions of separation should be that given in the relevant paragraph in Volume I, Part I of Annex 10.

2.3 Deployment of VORs

2.3.1 *Number 4 — Track guidance:* VORs should be deployed along ATS routes forming part of the agreed ATS route network and should be used to define the centre lines of such routes so as to ensure smooth transition of navigational guidance at the change-over point from one VOR to the next.

2.3.2 *Number 5 — Spacing between VORs:* Successive VORs providing track guidance along a given ATS route should be spaced at the maximum distance consistent with:

- a) the required track keeping accuracy;
- b) the lowest level at which navigational guidance along the route in question is required. In those cases where the VORs concerned serve ATS routes both in the upper as well as in the lower airspace, the requirements of the latter will dictate the spacing between the aids concerned.

Note 1.— With respect to 2.3.2 a), criterion number 9 is particularly relevant.

Note 2.— The requirement in 2.3.2 b) results from the quasi-optical propagation characteristics of VOR signals.

Note 3.— With regard to 2.3.2 b), VORs provided for use in the lower airspace only should not be frequency protected for utilization in the upper airspace.

2.4 Determination of designated operational range and height for VORs and DMEs

2.4.1 Number 6 — Designated operational range requirements: The designated operational range for individual VORs along specific route segments should, for planning purposes, extend up to half the segment length in question plus 10 per cent of that distance or 10 NM, whichever is greater. However, when successive facilities along a given en-route segment are spaced by a distance of 60 NM or less, each VOR should have a designated operational range covering the entire segment in question.

Note.— In those cases where special requirements for minimum operational range of adjacent VORs may be necessary, significant savings of frequency utilization may be achieved if the change-over from one VOR to the next is at the mid-point between the two VORs. This arrangement should be permissible provided total coverage of the route segment concerned is maintained (see criterion number 10).

2.4.2 Number 7 — Designated operational height requirement: In planning navigation coverage of VORs, the designated operational height should be determined by the highest level at which the aid concerned is planned to be used.

Note.— See also Note 3 to criterion number 5 (2.3.2 b) above).

2.4.3 Number 8 — Specifications of designated operational range for individual aids for frequency planning purposes: For frequency planning purposes the designated operational range of a specific VOR and/or DME should normally be expressed in one omnidirectional value, corresponding to the highest value of any segment length established for the aid in question. “Keyholing” may be applied whenever there are significant differences in

designated operational range for different sectors of the circular area of coverage of an individual facility.

Note.— The designated operational range and height should be expressed, for practical reasons, in the following units:

Range (in NM): 25, 40, 60, 80, 100, 150, 200.

Height (in terms of flight levels): 100, 250, 500.

2.5 Provision of navigational guidance

2.5.1 Number 9 — Changes of direction on routes: If other methods of determining the position of points where changes in the direction of ATS routes occur are not practicable, VORs should be deployed at these points.

2.5.2 Number 10 — Change-over points: Change-over points from one VOR to another on ATS routes should normally be established at the mid-point between the two aids. Where the change-over point is not at the mid-point between two aids or at the intersection of two VOR radials, its position should be specifically indicated on radio navigation charts. In such cases, the distance to the two VORs concerned should be indicated.

2.6 Deployment of DMEs co-located with VORs

2.6.1 Number 11 — Coverage requirements for DMEs: A DME, co-located with a VOR should operate to the limits of the designated operational coverage of its associated VOR.

2.6.2 Number 12 — Marking of “landfall” points: VORs situated at the end of long ATS route segments, along which navigation guidance provided by short-range station-referenced aids is limited (e.g. landfall points), should be provided with a co-located DME when a requirement for an increase in accuracy of navigation makes this essential.

2.6.3 Number 13 — Updating of airborne navigation systems: Where it is required to update airborne navigation equipment, appropriate VOR/DMEs provided for other reasons should be designated for this purpose.

— — — — —

Appendix C

Promulgation of Nominal Centre Lines of VOR-Defined Routes

1. DEFINITIONS

The nominal centre line of a VOR-defined route is an intended geographic track. It is composed of segments, each of which approximates a great circle track. The identification of each segment will contain the following elements:

- a) a specific VOR;
- b) the radial of that VOR which coincides, or nearly coincides, with the geographic track;
- c) the distance(s) from the VOR included in the segment.

2. PROMULGATION OF THE CENTRE LINE

2.1 The VOR radial published by the appropriate authority should normally be the value corresponding to the magnetic direction of the minor arc of the great circle containing the route segment from the VOR. A different

radial should be published where it can be established that a better average alignment or better coincidence at the change-over point is obtained (see Figures 1 to 3).

2.2 Application of this procedure will facilitate navigation close to the nominal centre line between VORs defining a route segment:

- a) even where systematic errors persist despite technical adjustments to the VOR;
- b) at high latitudes where convergence of meridians becomes significant in navigation;
- c) at or near the magnetic poles where isogonals are affected by magnetic anomalies.

2.3 The precise alignment of VOR radials may not always be known, due to the lack of flight testing capability, and may vary with time, due, for example, to periodical technical adjustments to VORs, switch-over to standby transmitters and meteorological effects. The published radial should, however, be the best approximation to the average direction of the radial over a period of time which is consistent with routine amendment of charts and aeronautical information publications.

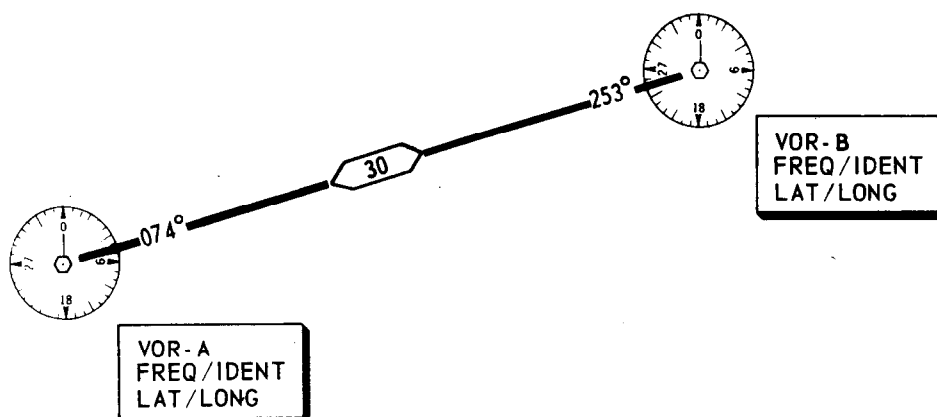

Figure 1. Standard charting of VOR route segment

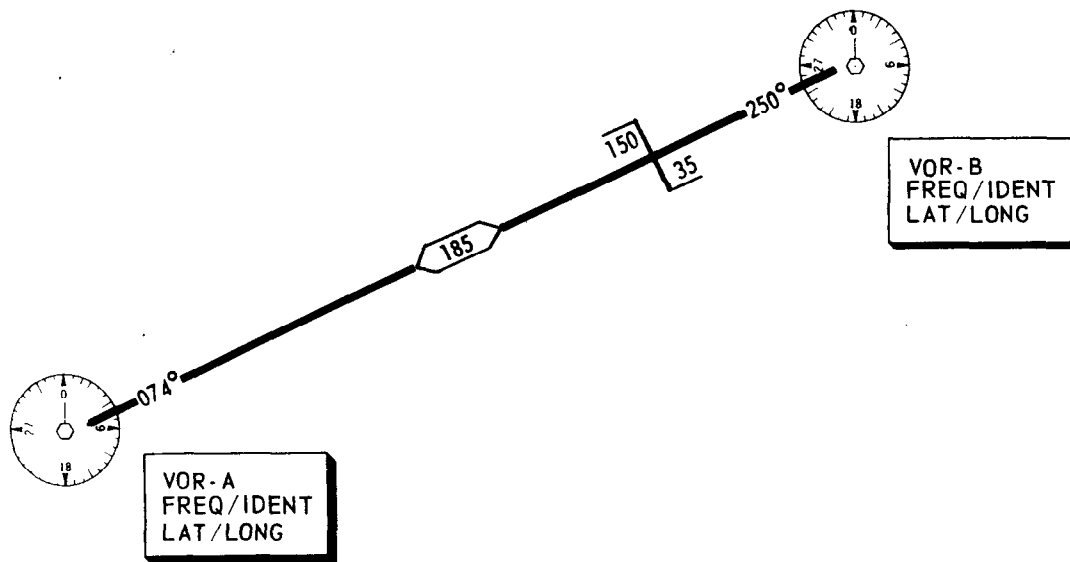

Figure 2. Charting of VOR route segment with off-centre change-over point

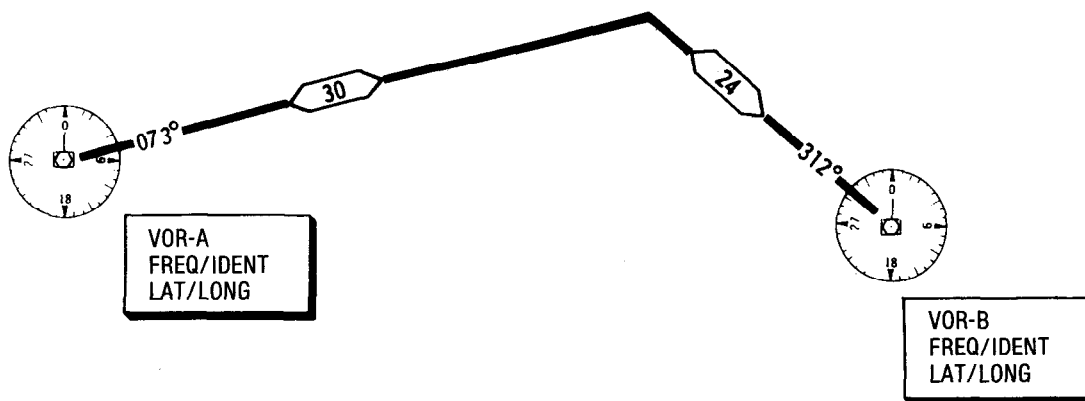

Figure 3. Charting of VOR route segment with dog-leg

Chapter 6

Area Navigation

6.1 INTRODUCTION

6.1.1 The increase in sophistication of airborne navigation equipment, both as regards that using information derived from ground-based aids as well as that operating in a self-contained mode inertial navigation systems (INS), was believed to make it feasible that older forms of navigation, i.e. operating from navigation aid to navigation aid along routes which were more or less permanently established, could advantageously be replaced or complemented by one whereby aircraft could plan and operate along the most direct route between their point of departure and their destination. This concept is known as area navigation (RNAV).

6.1.2 Apart from the economic advantages to operators, RNAV was also expected to permit providers considerable economy in the provision of radio aids to navigation because under the concept of area navigation it would no longer be necessary to provide such aids at each significant point and/or aerodrome if that point was located within the area of coverage of another existing aid. The economic aspect to operators was made even more desirable after 1973, when general developments in the energy field and their consequences on the economy made fuel conservation a much more important topic in the conduct of flight operations.

6.1.3 It was for this reason that RNAV received growing attention especially on the part of operators engaged in commercial air transport operations. Studies conducted by a number of States and practical experience acquired in cases where the area navigation concept is being applied have shown, however, that the widespread application of flights along random routes will require very careful consideration and that much preparatory work, both by providers and users, is required before area navigation can be expected to become a general substitute for the present method of operation along established air traffic services (ATS) routes (see Chapter 5).

6.1.4 In reviewing the application of area navigation in a given environment, it was found that two aspects assumed

the dominant role. One concerned the question of the horizontal separation minimum which needed to be applied between the flight paths of aircraft operating along random routes; the second aspect concerned the control methods which had to be applied to such aircraft.

6.1.5 Horizontal separation minima are primarily dependent on the accuracy of navigation which can be expected from aircraft operating in this mode, i.e. it must be assumed that each aircraft will meet agreed values of accuracy when air traffic control (ATC) determines the separation minima to be applied to each pair of aircraft. To achieve uniform navigation accuracies it is practically impossible to avoid establishing some type of minimum navigation performance specification expressed in terms of equipment fit (generally VHF omnidirectional radio range (VOR)/distance measuring equipment (DME) combined with a navigation computer on board the aircraft, or INS). Experience has shown that, in an environment where an appreciable portion of the air traffic is composed of international flights, achieving uniform navigation accuracies is difficult because operators views vary as to the manner in which the accuracy required can be met, both as regards the type of equipment and methods to be used as well as the need for back-up reliability.

6.1.6 When area navigation along random routes is applied, the most outstanding problem facing ATC is the presentation of the different routes planned by individual flights in such a manner that it becomes immediately apparent when and where individual aircraft will become essential traffic in relation to each other. This problem applies especially in view of the fact that this presentation may change frequently with the insertion of new flights into a given traffic situation. A further problem associated with area navigation along random routes is that co-ordination between adjacent ATC units becomes difficult because, in such cases, transfer of control points will change continuously, unless application of area navigation is restricted to within one control area at a time; a situation which, in most cases, would negate the advantages operators expect to derive from its use. The assumption that these problems can be resolved by the availability of radar

and/or automation may be correct; however, so far practical results have not been confirmed on a sufficiently large scale.

6.1.7 It would therefore appear, at least for the time being, that the use of the area navigation concept will be confined to selected portions of the airspace and/or specific groups of users which are prepared to meet a mutually agreed upon degree of accuracy in navigation while operating in the portions of airspace defined for that purpose. A further expansion appears possible by using area navigation in areas of high traffic density in order to establish parallel ATS routes without the need for the provision of additional navigation aids to relieve airspace congestion in areas where airspace is at a premium. Establishment of parallel ATS routes presupposes, however, that the increased accuracy in navigation can be met continuously and in a reliable manner by all aircraft engaged in routine operations in such an environment.

6.2 USE OF AREA NAVIGATION

6.2.1 As previously indicated, the use of RNAV in a given area, and the user's ability to comply with the necessary conditions, must be based on:

- a) firm agreements between the provider authority and all potential users that they will meet, on a continuous basis, the requirements for navigation accuracy upon which the application of RNAV is based;

- b) provisions which specify, in detail, the procedures to be used for aircraft in transition between an established ATS route network and an RNAV area. These provisions must also cover cases of temporary loss of the RNAV capability by aircraft operating in an RNAV area;
- c) provisions which ensure a continued monitoring of the navigation performance in the RNAV area in order to ensure that the conditions upon which RNAV is based are met;
- d) provisions which envisage a suspension of RNAV and a reversal to other forms of operation in case a general deterioration of the situation is noted. These provisions should also cover the case of the restoration of RNAV whenever the causes, having led to its suspension, have been eliminated;
- e) provisions regarding the full or partial immediate suspension of the use of RNAV whenever essential facilities upon which RNAV is based are temporarily out of service. These provisions should include the establishment of a list of such facilities and of the effects their withdrawal from service (either individually or in any combination) is likely to have on the use of RNAV.

6.2.2 It will also be necessary to publish full details on the use of RNAV, especially with regard to the role of responsibility pilots and operators will have in assuming its application, in order to stress the fact that RNAV is a collective effort by both the ground services and flight crews concerned.

Chapter 7

Requirements for Terminal Facilities

7.1 INTRODUCTION

7.1.1 As air traffic tends to concentrate in the area around aerodromes, especially those serving major population centres where the demand for air transportation is highest, it is essential that such areas be provided with adequate facilities in order to be able to accommodate this traffic. If adequate facilities are not provided, the repercussions of traffic accumulating in such areas will be felt not only by those aircraft constituting such traffic, but will also spread to the flow of air traffic bound for other locations. At some very busy aerodromes experience has already shown that such repercussions can spread over very large areas and affect traffic for a considerable distance away.

7.1.2 In discussing the various aspects involved in establishing requirements for terminal facilities it is not intended to describe in detail the various aids and their use in forming part of the terminal facilities. However, it is intended to mention only those points which concern ATS directly and the need for these points to be taken into account in ATS planning.

7.2 TERMINAL VORs AND OTHER AIDS

7.2.1 Whenever traffic density and/or complexity requires that a terminal control area (TMA) be established around one or more aerodromes with the associated routing patterns for departing and arriving traffic (e.g. standard instrument departure procedures (SIDs) and standard terminal arrival routes (STARs)), it is generally necessary to establish a number of exit/entry points at the edges of the TMA — at least with respect to those ATS routes which carry the bulk of the air traffic in that TMA. Exit/entry points can be achieved in a number of ways, i.e. by reference to a VHF omni-directional radio range (VOR) radial and a distance along the radial measured by the collocated distance measuring equipment (DME); provision of a locator or an NDB, depending on the coverage

required. The operational need for additional, special navigation aids to establishment of exit/entry points should be reviewed critically so that a proliferation of aids serving a limited use only can be avoided where possible.

7.2.2 The need for the establishment of SIDs and STARs should also be very critically examined because experience has shown that, once established, controllers tend to use these procedures as convenient substitutes for the application of diligent control techniques. Such practices may require aircraft to fly unnecessary and unjustified complex patterns with the resultant undesirable economic consequences. However, where SIDs and STARs establishment is justified, it should be ensured that they can be flown with reference to navigational guidance alone because if their use requires extensive and prolonged radar vectoring from the ground it will have adverse consequences on the workload of controllers and on their capacity to handle air traffic in general.

7.3 CRITICAL WEATHER OPERATIONS

7.3.1 Initially, instrument approach procedures were developed only for those occasions when, because of meteorological conditions, it was not possible to conduct a complete approach and landing in accordance with visual flight rules (VFR). Depending on the type of air traffic operating at a specific aerodrome, this fact still holds true.

7.3.2 Where instrument approach procedures are established, the appropriate State authorities (not the air traffic services (ATS)) establish, for each instrument approach procedure, specific minimum values of height of cloud base and visibility which must be respected when using the related approach procedure. In some cases, however, States leave it to operators to ensure compliance with published minima (or higher values as determined by the operator) on the understanding that pilots are entitled to conduct an approach on a "look-see" basis and discontinue the approach when it cannot be completed. In other cases, States refuse pilots this privilege and take it upon

themselves to enforce compliance with the minima by refusing clearance for approach and landing when the minimum values of height of cloud base and/or visibility do not prevail.

7.3.3 In any case, the question of specific minimum approach values has to be determined between the operator and services other than the ATS. ATS should not be required to assume enforcement responsibilities in this respect. Nevertheless, ATS plays an important role in this matter because of timely information provided to pilots in critical situations enabling them to arrive at the operationally correct decision (see Part I, Section 2, Chapter 2, 2.2.9 on OFIS, and 2.2.10 on ATIS and Part I, Section 2, Chapter 10, 10.3 on ATS).

7.3.4 With the advent of faster and heavier turbo-jet aircraft to air transport, it was found that these aircraft required guidance along their approach regardless of prevailing weather conditions. As a consequence, at aerodromes used by such aircraft, an ILS was required to provide for at least the main landing direction used in critical weather conditions, even if the prevailing meteorological conditions alone would not have justified the provision of such equipment.

7.3.5 In recent years, much international effort has been invested in the development of an improved instrument landing system which is intended to overcome certain shortcomings of today's ILS as regards navigational guidance provided to aircraft on approach, i.e. more flexible flight path, continuous distance information from touchdown, better technical performance in critical terrain locations, etc. The new system is known as the micro-wave landing system (MLS). The progressive replacement of ILS with MLS can be expected to have significant beneficial effect on the handling of air traffic by ATS. This fact is due mainly to the greater flexibility which MLS permits in the sequencing of arriving air traffic. With MLS, for instance, it will no longer be necessary for ATS to require all aircraft to go to a common point to start their approach to land; thus permitting a more expeditious flow of arriving traffic.

7.3.6 With the increased importance of air transport as a routine means of travel, its regularity also gained in importance. It was for this reason that efforts have been made to develop equipment and associated procedures which would ensure that, even under adverse meteorological conditions, a flight could be conducted as planned, i.e. even the minima prescribed for take-off and landing could be lowered to a point where weather was no longer a determining factor in whether or not a flight could be started or would arrive in time at its destination as planned. Work in this field has been conducted under the heading of

“All Weather Operations” and has now resulted in a programme which envisages a step-by-step method of lowering the prescribed landing minima in phase with the provision of suitable ground equipment at selected aerodromes and related measures by operators regarding airborne equipment and flight crew proficiency.

7.3.7 The various steps envisaged in the all-weather operations programme are referred to as categories of operation (CAT). Categories have been numbered from I to III. It should be noted, however, that while each of these categories prescribes specific technical performance characteristics of the ground equipment used for their conduct, these characteristics taken in isolation do not constitute a basis for the application of the related category of operation, e.g. an ILS may meet the technical performance required for CAT II operations without it ever being used for such operations. The decision to conduct a specific category of operation at a specific aerodrome depends exclusively on the operators in consultation with the authorities concerned. Apart from relevant operational technical considerations, cost-effectiveness considerations play a very large part in the decision-making process. More detailed information on the technical and operational aspects of this subject is contained in Part II, Section 5, Chapter 2 of this manual as well as in ICAO Doc 9365 — *Manual of All-Weather Operations*.

7.3.8 There are a number of other aspects of categories of operations which are of direct concern to ATS and which need to be taken into consideration in work in this field. These are:

- a) contributions expected from ATS during the conduct of all-weather operations;
- b) arrangements required during the extended transition period of application of one category of operations to the next, i.e. transition from CAT I to CAT II operations;
- c) arrangements required to maintain pilots' proficiency in the conduct of such operations.

7.3.9 With respect to contributions expected from ATS, one essential point is that ATC ensures that the area on the aerodrome required to be protected from intrusion in order to ensure the proper functioning of the ground equipment, i.e. the “critical area”, is kept clear during the period when approaches are in progress. In addition, air traffic control (ATC) should ensure that any information, essential for the pilot's decision to continue an approach, is brought to his attention in a clear and concise manner without delay, i.e. latest meteorological information, including runway visual range (RVR), wind shear, etc., changes in the operating status of essential components of the ground

equipment, etc. In meeting requirements for essential information, due account should also be taken of the fact that passing an excess amount of irrelevant information, as well as transmitting information at a moment when the pilot's attention is concentrated on critical manoeuvres, can have serious detrimental effects on the safe conduct of the approach by appreciably increasing the stress on pilots. It is therefore essential that ATS procedures for all-weather operations be clearly understood between operators and the ATC unit concerned and that ATC personnel be thoroughly trained in this respect, taking into account relevant local factors which may have a bearing on this matter.

7.3.10 For the reasons explained in 7.3.7 above, it can be expected that the introduction of specific categories of operation at specific aerodromes will be done progressively and that it may take a considerable time before such categories are fully used by the majority of aircraft operating into that aerodrome (see 7.3.8 b)). Situations will therefore arise where, under a given set of circumstances, some of the arriving aircraft may be able to conduct an approach to land while others cannot, but where their arrival sequence is independent of their respective capabilities. It will therefore be necessary to make arrangements which will permit suitably equipped and qualified aircraft to conduct their approach in a sequence different from the "first come — first served" sequence normally applied by ATC. In making such arrangements it should be clearly understood that they do not contravene the principle of providing service on a non-discriminatory basis, but that the opportunity to land offered to those aircraft which are able to do so safely will also benefit the others because it assists in easing the general traffic load normally experienced under such conditions (see also Part II, Section 5, Chapter 2, 2.5.3).

7.3.11 As mentioned in 7.3.8 c) above, the conduct of CAT II and III operations, in particular, requires that pilots retain their proficiency in conducting such operations. This requirement presupposes that the pilots have the opportunity to practice such approaches at frequent intervals. It will therefore be necessary for operators to arrange for practice approaches at those aerodromes where the conduct of the appropriate category of operation is possible. If such practice approaches are conducted during a period where traffic is frequently heavier than usual, i.e. the holiday season, it could have undesirable effects on the flow of other air traffic. It therefore appears advisable that ATC units at the aerodromes concerned develop, in co-ordination with operators concerned, programmes for the conduct of such practice approaches, and specify not only the times when such approaches can best be fitted in with other traffic using the aerodrome, but also ensure that

equal opportunity is afforded to all operators confronted with this problem (see also Part II, Section 5, Chapter 2, 2.5.4).

7.4 SURVEILLANCE OF GROUND MOVEMENTS

Note.— See also Part II, Section 5, Chapter 4.

7.4.1 The need for adequate surveillance of ground movements is particularly important at aerodromes where low ground visibility occurs rather frequently and where the layout of the movement area is complex. Complex movement areas are mainly found at large busy aerodromes, which are in most cases geographically situated so that winds do not occur in a prevailing direction (e.g. near seashores or large bodies of water or in flat regions). The result of this condition is that runways are provided in different directions, thus creating a complex network of taxiways and resulting taxi routes to get aircraft to and from the runway in use. A further complicating factor is the traffic density at such aerodromes. The more aircraft and associated ground vehicles that are simultaneously moving on the aerodrome, the greater the likelihood of conflicts between them.

7.4.2 From the above, it is evident that there are three main factors which govern the need for surveillance of ground movements:

- a) the frequency of occurrence of critical ground visibility conditions;
- b) the traffic density, including that of ground vehicles;
- c) the complexity of the aerodrome lay-out.

7.4.2.1 A further point which needs to be taken into account is the necessary arrangements between ATS and other agencies regarding the division of responsibility for the provision of services to aircraft and other traffic on the movement area (see also Part I, Section 2, Chapter 2, 2.4).

7.4.3 The means to effect surveillance of ground movements can range from very simple arrangements at smaller aerodromes with comparatively light traffic density and non-critical visibility conditions to very complex systems at large and busy aerodromes where critical visibility conditions frequently occur. Because of the many choices which are available and because local conditions at specific aerodromes play a major role in the determination of the most adequate solution, it is not possible to offer a standardized solution to this question, except that procedural arrangements and publications should not deviate

from agreed basic principles as far as phraseology and/or use of standardized symbols in publications (especially on maps and/or diagrams) are concerned.

7.4.4 Amongst the many technical and operational considerations involved in planning surveillance of ground movements are three aspects especially needed to be kept in mind. These are:

a) the need to keep arrangements for pilots as simple and straightforward as possible and free of any possible ambiguities as to action expected of aircraft moving on

the ground. Simplicity of procedures is preferable to utmost efficiency if the latter can only be achieved by complex and complicated procedures;

b) the need to keep cost-effectiveness in mind, especially when considering the provision of complex electronic aids;

c) the need to ensure that, from the start, planning is done with the active participation of airport authorities, operators of aircraft and those constituting other traffic on the movement area (operators of bus services for passengers, freight vehicles, the fire fighting services, catering services, etc.) so that their legitimate requirements will receive due consideration.

Chapter 8

Requirements for Communications

8.1 INTRODUCTION

8.1.1 Communications are a vital part of the provision of air traffic services (ATS) and their timely and dependable availability have a most significant bearing on the quality of the service provided by ATS. It is therefore essential that communication requirements form an integral part of any ATS planning, especially in view of the fact that their provision is frequently dependent on co-ordinated efforts by other than the air navigation services (i.e. the general telecommunication services). This co-ordinated effort not only applies to the availability of required communication links but also with respect to their quality of performance reliability and the time required for their restoration to full service in case of breakdowns. Appropriate arrangements covering these aspects should therefore be concluded between the air navigation planners and other parties concerned. These arrangements should also cover the long-range aspects of planning communications where new or greater demands are expected or required at a future date in order to meet the technical needs of more sophisticated ATS equipment, i.e. data links, high-speed transmission circuits, etc.

8.1.2 In formulating communication requirements care should be taken to clearly state the operational requirements without indicating the manner in which that requirement is to be technically satisfied. However, it is also important that technical limitations are not used as an excuse to degrade the stated operational requirements. Experience has shown that any ambiguities regarding respective responsibilities between those charged with the formulation of operational requirements and those charged with technical realization can have very detrimental consequences on the facilities concerned, resulting in even more detrimental effects on the operation of ATS.

8.2 FIXED SERVICE COMMUNICATIONS

8.2.1 The basic provisions regarding requirements for fixed service communications by different ATS units are

contained in Annex 11. They are therefore not repeated in this manual. However, there are a number of additional aspects which merit consideration. These are:

- a) the consolidation of different communications requirements into one technical means;
- b) the frequency of breakdowns and the time required for repair or replacement of individual circuits;
- c) the quality of the communications;
- d) the arrangements for terminal fixed communication links.

8.2.2 With respect to consolidated communications requirements (8.2.1 a) above), modern communications technology makes it now feasible to use one technical carrier, on a time-sharing basis, to satisfy a number of aeronautical communication requirements. A typical example of this approach is the common ICAO data interchange network (CIDIN) which is designed to accommodate not only ATS requirements for data interchange but also the exchange of meteorological and aeronautical information service data between interested services as well as other data transmission now carried by the aeronautical fixed telecommunication network (AFTN). In this case, it is of the utmost importance that the operational requirements for the exchange of ATS data by normal or high-speed teletype transmission and/or by direct data exchange between air traffic control (ATC) computers be specified as precisely as possible. This applies to both the amount of data to be exchanged and the acceptable time limits, as well as the reliability and integrity of such exchanges. In addition, it is necessary to decide whether direct voice communications between ATS units are to be incorporated into such a common carrier system (which is technically feasible) or whether voice communications should be met by a different carrier. In the latter case, present trends are directed more towards keeping voice communications separate from the common carrier system (AFTN) because of their vital importance to the immediate resolution of critical situations, should these occur, and as a back up in case the common carrier is temporarily out of service.

8.2.3 Since ATS fixed communication links are normally not under the full control of the air navigation services

(from terminal to terminal), it is important to keep a continuous check on the frequency of their breakdowns and the time required to restore these communications to full service (8.2.1 b) refers). In many cases it has been found that the authorities responsible for general telecommunications, providing fixed ATS communications circuits, are not, a priori, prepared to accord these circuits the special status required for communications involved with the safeguarding of human lives, especially provisions regarding priority maintenance and repair. In addition, alternative physical routings of potential back-up circuits are also not, in all cases, envisaged. It is therefore essential that communications breakdowns and time required for restoration be kept under close review and that, where necessary, appropriate arrangements for corrective action are made.

8.2.4 With regard to the quality of communications (8.2.1 c) above), much of what has been said in the previous paragraph also applies to voice communication circuits. Arrangements have been concluded whereby in some cases, switching through an intermediary terminal has been agreed upon as a means to satisfy a requirement for a connexion between two ATC units, both of which are connected to the intermediate third unit. This arrangement is done whenever operational and economic conditions permit. Experience has also shown that, if such an arrangement is not co-ordinated with the technical providers of the circuits concerned, it can lead to difficulties because the technical performance of the circuits in question (especially voice amplification) may not be sufficient to accommodate the additional use. Consequently, when through-switching is used, the speech quality may be insufficient to allow for reasonably acceptable communications. It has also been found that the cost charges for through-circuits are calculated differently than if they were only used between two ATS units. It is therefore important that such arrangements are clearly indicated in the technical specifications for fixed communication circuits and the agreements concluded between users and the providing agency are adequate.

8.2.5 In certain cases, it could also be advantageous if, for traffic flow planning purposes, a number of ATC units (primarily area control centres (ACCs)) in a given area were provided with the possibility of using interconnecting voice circuits in a conference-type arrangement to deal with critical ATC situations. Early identification of the technical pre-requisites for such arrangements is very important and should be done in good time so that necessary preparatory measures can be taken by all technical providers concerned.

8.2.6 ATC units frequently find the terminals for different communications circuits, and especially voice circuits, are installed independent of each other with the result that controllers are required to use four or five different telephones during any one given period of time. This arrangement is operationally unsatisfactory and should be avoided. All such terminals should be incorporated into one single communications keyboard or selector panel, permitting the operation of each of the circuits from one terminal. Co-ordination with the technical providers is required because, in some cases, the differing technical specifications involved do not always permit such a grouping of different circuits into one panel.

8.3 AIR-GROUND COMMUNICATIONS

8.3.1 ATS air-ground communications should be designed so that they require the least number of frequency changes for aircraft-in-flight, compatible with the provision of the required service. They should also provide for the minimum amount of co-ordination between ATS units. Basic elements for the determination of the need for air-ground communication channels are given in Appendix A.

8.3.2 Uniform values of designated operational range and height of very high frequency (VHF) air-ground communication channels used for specific ATS functions should be in accordance with the table shown in Appendix B. Deviations from these values at specific locations or for specific functions should be made only in those cases where adequate operational justification for such a deviation is provided by the ATS unit concerned.

8.3.3 In order to achieve optimum economy in the common use of international and national ATS air-ground radio communications frequency spectrum (VHF), the criteria outlined in Appendix B should be applied uniformly to all facilities using VHF air-ground communications regardless of who is operating them.

8.3.4 Since the use of frequencies for national VHF air-ground communication requirements has a bearing on international frequency assignment planning, States should:

- a) normally base their national requirements on the values shown in Appendix B regarding designated operational range and height;
- b) provide ICAO with as much information as possible in advance of planned national requirements;

c) submit those national requirements which are expected to cause operational and/or technical difficulties by their implementation to any appropriate ICAO body so that the available frequency spectrum can be shared on a commonly agreed basis and in accordance with uniform criteria.

8.3.5 In addition, VHF installations serving national purposes and sharing the frequency band for international requirements should fully meet the appropriate specifications for their technical performance contained in Annex 10, Volume I, Part I, both as regards ground and airborne equipment.

8.3.6 The progressive reduction of air-ground communications can also have an effect on the number of channels needed by ATC units (especially ACCs). It is for this reason that considerations regarding this subject have been included in Appendix C to this chapter. These considerations are based on experience gained by States in the European (EUR) region.

8.3.7 It is now accepted practice that ATS requirements for air-ground communication channels serving international purposes are included in the air navigation plan for a specific region. In those ICAO regions where the use of frequencies for national air-ground communication requirements has a bearing on international frequency assignment planning, the Regional Office concerned also issues a table containing all requirements for both international and national assignments. This table provides a means for conducting a reasonable planning exercise regarding both the operational need for channels and their technical provision in terms of specific frequencies. Therefore at regional meetings, or on any other occasion where this subject is dealt with, it will be sufficient if States present only those international requirements which are new or which need to be changed in comparison with what is already in the plan. In those cases of frequency assignment planning where national requirements need to be taken into account such presentations should also cover national requirements. The presentation of detailed statements by States of new or changed requirements for air-ground communications for air traffic services and explanation of a sample form used for this purpose are shown in Appendix D to this chapter.

8.4 RECORDING AND RETENTION OF ATS DATA

8.4.1 ATS data is a significant source of information in the reconstitution of incidents and/or accidents concerning

aircraft. It is essential that information on the traffic situation at any given moment, as well as records indicating who was performing which function within an ATC unit, be kept in their original state as long as there is a reasonable possibility that such information may be required.

8.4.2 Written records (flight progress strips, ATS messages, duty logs, etc.) should be retained for a minimum of 90 days and should only be destroyed thereafter if no specific need for further retention has come to light. When the need for such data has become apparent destruction of the material should only be done after specific authorization has been granted by the appropriate authority.

8.4.3 In addition, written records should always be made in an indelible manner. Erasures should not be permitted. Recorded data should be corrected by striking out the information in such a manner that it remains legible and recording the correct data in a convenient place near the information that has been struck out (see also Part II, Section 3, Chapter 4).

8.4.4 Voice recordings of air-ground or telephone communications should be retained for a minimum of 30 days, again with the proviso that those for which a need for further retention has been made known shall be destroyed only after special authorization to do so has been received.

8.4.5 Both written records and voice recordings that require retention should also have appropriate arrangements made regarding their storage so as to prevent such data from being tampered with. The storage of voice recordings requires particular attention because, without such safeguards, unintentional or intentional exposure to electromagnetic radiations may occur.

8.4.6 Whenever voice recordings are used as evidence in the investigation or legal proceedings regarding incidents or accidents, it should be kept in mind that such recordings, while factually correct, will not always convey the entire environment in which the information was received at the time of its recording. Voice recordings may therefore give an erroneous impression of the situation; a fact which must be taken into account when interpreting voice recordings.

8.4.7 Based on a recommendation of the Accident Prevention and Investigation Divisional Meeting in September 1979 (Doc 9280), it is now a Recommended Practice that, where radar is being used by ATC, the information so obtained should be recorded in order to assist in the investigation of accidents and/or incidents and in search and rescue cases. In addition, it was felt that such recordings could also be of use in the evaluation of the ATC and/or radar system and serve as a training aid.

8.4.8 When using such recordings in investigations, it should, however, be kept in mind that what has been said in 8.4.6 above with respect to the relative value of voice recordings applies even more so to radar recordings. Recordings based on data as provided by the radar antenna may have little resemblance to what the controller concerned saw on his display at the time of the incident in question because the controller may have used the off-centring device or limited the range on his display to suit his particular needs. To be conclusive, it would be necessary to record the presentation on each display used for control purposes. Furthermore, experience seems to show that, in order to be able to make a reasonable reconstitution of a given situation from recorded radar data, it is necessary to provide for synchronous integration of the related voice recordings and, where automatic data processing equipment is used, of records kept by such equipment. Such a requirement could result in an elaborate installation whose initial and current costs need to be considered in relation to the likely benefits which may be

derived from its use. These costs would also have to be assessed in relation to pressing requirements of ATC for other facilities or equipment in order to ensure that proper priorities are given to the acquisition of such a facility.

8.4.9 One point which plays a significant part in the assessment of recorded radar data is the role that the recorded data are expected to have in the investigation of incidents and/or accidents. Such an assessment depends on local factors such as coverage of radar equipment, types and density of traffic observed by the radar in question, likely frequency of occurrence of situations where recorded radar data may be of use, etc.

8.4.10 Recorded radar data may be of use in the evaluation of the ATC system or the performance of the radar equipment, or they may be used for training purposes. However, these possibilities, taken in isolation, will not justify the need for radar data recording.

— — — — —

Appendix A

Basic Elements for the Determination of the Need for ATS Air-Ground Communication Channels and their Economic Use

1. DETERMINATION OF THE NEED FOR ATS AIR-GROUND COMMUNICATION CHANNELS

1.1 Description of terms used

In describing the basic elements involved in the determination of the need for ATS air-ground communication channels, the following terms are used:

- a) *ATS radio control position.* That part of an ATS unit performing a specific ATS function requiring the direct and unrestricted access to a VHF air-ground communication channel.

Note.— At present, this requirement is met by assigning a discrete channel for each ATS radio control position.

- b) *Sector.* A defined portion of the airspace within which ATS are provided by one or more ATS radio control positions.

Note.— Normally a sector is part of a control area and/or an FIR/UIR. It can also be a defined area around major aerodromes wherein specific approach control functions are performed.

1.2 Factors to be taken into account

1.2.1 When determining the need for ATS radio control positions, the following factors are taken into account:

- a) the amount of air traffic;
- b) the configuration of the airspace;
- c) the method of control used;
- d) effects on the over-all communications workload resulting from the systematic reduction of air-ground communications and/or the use of “silent control”;

Note.— “Silent control” is a method whereby ATC individually advises aircraft when to make the next report, based on their route of flight and the existing traffic situation.

- e) special national requirements;
- f) the average capability of the control personnel.

1.2.2 The amount of traffic should be expressed in the following manner:

- a) the number of movements of air traffic handled by an ATS unit or part thereof during a given period of time (*traffic load*);
- b) the traffic load handled during a specified seven-day period (*weekly traffic load*);
- c) the traffic load handled during that clock hour in the period chosen in accordance with 1.2.2 b) above during which the highest number of movements occurs (*peak traffic load*);
- d) the traffic load at the busiest instant within the peak hour as defined in 1.2.2 c) above (*maximum instantaneous traffic load*).

Note.— The values referred to in 1.2.2 b), c) and d) above should also include traffic handled by the relevant ATS radio control position on UHF, if a channel in this frequency band is provided.

1.2.3 Expressing the amount of traffic in the above-described manner and terms will make it possible to compare data obtained (for assessment purposes) with those provided by traffic forecasting groups in those areas where such groups function. If comparisons are required for other areas, the methods of data collection on air traffic movements used by States should be taken into account.

1.2.4 The configuration of the airspace should be broken down into and should take account of:

- a) number of ATS routes served;
- b) number of intersections of ATS routes;
- c) number of major terminal areas and total number of aerodromes (including military) in the area;
- d) proportions of aircraft in level flight and in climb or descent;
- e) airspeeds and levels used by groups of aircraft constituting a significant portion of the total traffic.

1.2.5 When assessing the method of control used, it is necessary to differentiate between the following methods:

- a) procedural control;
- b) procedural control supplemented by the use of varying degrees of primary radar control;
- c) radar control based on the use of primary radar;
- d) radar control based on the use of secondary surveillance radar (SSR) with Mode C;
- e) use of automatic equipment by the ATS radio control position;
- f) use of automatic data exchange between ATS units.

1.3 Effects resulting from the reduction in air-ground communications

While it may be difficult to quantify the effects achieved from the systematic reduction of air-ground communications or the application of the "silent control" concept, it will nevertheless be useful if reasonable allowances are made for this factor in the assessment of the need for ATS radio control positions, especially in those cases where the possibility of combining two or more ATS functions into one single ATS radio control position is being considered. Appendix C presents some considerations regarding reductions of air-ground communications in specified areas and along selected ATS routes.

1.4 Special national requirements

1.4.1 As special national requirements, by virtue of their nature, vary from State to State, no generally applicable method of assessment can be developed. It is, however, noted that methods to accommodate identical national requirements also vary considerably from State to State, some of them requiring a minimum of effort on the part of ATS, others resulting in considerable workload.

1.4.2 Special national requirements for ATS communication should therefore be reviewed on the national level but should draw on experience obtained by other States so that the most efficient method of satisfying a specific national requirement is selected by the State concerned.

1.5 Average capability of the control personnel

The average capability of control personnel has the largest single influence on the problem under consideration. However, since it is, to a very large extent, determined by administrative, organizational and social considerations, which vary considerably from State to State, it will therefore escape uniform assessment for a long time. In addition, subjective judgement enters into this question to an appreciable extent.

2. ECONOMY IN THE USE OF ATS AIR-GROUND COMMUNICATION CHANNELS

2.1 Arrangements for ATS VHF air-ground communications should be reviewed periodically and, where necessary, corrective measures taken, especially with regard to:

- a) the combination of more than one ATS function into one ATS radio control position;
- b) the elimination of discrete channel requirements for the provision of direction-finding services;
- c) the elimination of multiple discrete channel requirements for precision approach radar (PAR) purposes;
- d) the misuse of emergency frequency 121.5 MHz.

2.2 Stated requirements for VHF air-ground communication channels serving aerodrome control and approach functions should be reviewed as a matter of routine in the light of traffic developments with a view to reducing them to the minimum, commensurate with the safe and efficient performance of the services in question. Channel requirements thus eliminated should be notified to ICAO so that if necessary the regional plan concerned can be amended and frequencies concerned re-assigned for other, justified purposes.

2.3 When a requirement for two air-ground communication channels covering the same area has been established, i.e. one for the provision of procedural control, the other for radar control, such a requirement should be reviewed with a view to the earliest possible combination of the two ATS functions. Any such combination of functions and release of a communication channel should be notified immediately to ICAO.

2.4 Taking account of the increase in general aviation and non-scheduled commercial operations, it will be permissible to assign more than one air-ground communication channel for flight information service (FIS) functions within a flight information region (FIR) in the lower airspace. However, this should be justified by appropriate traffic data provided by the State requesting such an assignment.

2.5 The provision of supplementary services such as limited FIS on channels reserved for aerodrome control tower functions or their use for general purpose communications should only be permissible to the extent that the performance of such supplementary services does not result in the need for additional channels.

Appendix B

Table of Uniform Values of Designated Operational Range and Height of VHF Air-Ground Communication Channels for Specific ATS Functions

AIR-GROUND COMMUNICATIONS FOR	SYMBOL	SERVICE (Note 1)		REMARKS
		RANGE NM (Note 2)	HEIGHT FL	
1	2	3	4	5
Aerodrome control, including D/F service	T	25	40	*Unless difference values determined by requirements of arriving aircraft
Precision approach radar	PR	25	40	
Automatic terminal information service (ATIS)	AT	60*	200*	
Approach control (low) including radar control and/or D/F service	(APP) L	25	100	
Approach control (intermediate) including radar control and/or D/F service	(APP) I	40	150	
Approach control (high) including radar control and/or D/F service	(APP) H	50	250	
Area control service (lower airspace) including radar control	(ACC) L	Within specified area	250	
Flight information service (lower airspace)	F	Within FIR	250	
Area control service (upper airspace) including radar control	(ACC) U	Within specified area	450	

Note 1.— The figures for service range and height in columns 3 and 4 may be altered in accordance with regional air navigation agreement. However, experience in complex areas has shown that the values indicated here are satisfactory to meet the most demanding situations.

Note 2.— Cases where a significant deviation from circular coverage is possible shall be specified.

Note 3.— The requirements for coverage of VHF channels used for the broadcast of OFIS messages are determined by regional air navigation agreement.

— — — — —

Appendix C

The Reduction of Air-Ground Communications

1. INTRODUCTION

Considerations regarding the reduction of air-ground communications reflects results of trials conducted by EUROCONTROL 1977, in co-operation with the International Air Transport Association (IATA), aimed at a reduction in radiotelephony in specified areas and along selected ATS routes.

2. CONSIDERATIONS

The following considerations should be taken into account in the reduction of air-ground radiotelephony communications between pilots and ATS units:

a) the development of procedures for the reduction of air-ground radiotelephony communications in a specified area requires close co-operation between ground services and the users and should, in any case, include practising controllers. Such co-operation should not only be maintained during the planning stage, but

should also continue throughout the initial period of introduction of such procedures to ensure the rapid detection and correction of initial difficulties;

b) reduction of air-ground radiotelephony communications can comprise all or any of the following measures:

1) the systematic elimination of as many compulsory position reports as possible or their transformation into on-request position reports only;

2) the reduction of the content of position reports still required;

3) the reduction of the content of the initial call made by an aircraft when establishing contact with a new ATS unit or sector;

c) in any case, the need for an initial call when entering the area of an ATS unit and a ground-initiated call to an aircraft prior to its leaving that area are considered to be a minimum requirement for air-ground communications;

d) procedures used in order to obtain a reduction of air-ground communications in specific areas should be as uniform as possible throughout the region;

e) measures taken in order to reduce air-ground communications should be published with an advance notice of at least *two AIRAC cycles*.

— — — — —

Appendix D

Presentation of Detailed Statements by States of New or Changed ATS Requirements for Air-Ground Communication Channels

SAMPLE FORM:		Information submitted by State: _____							
		Sheet No: _____							
FUNCTION TO BE SERVED		Number of channels	SERVICE		Frequency	STATUS OF FREQUENCY		Remarks	Remarks by frequency assignment planners
Unit in charge (for symbols see Appendix B)	Description of function		Range	Height		INT. or NAT.	Imple- ment- ation		
1	2	3	4	5	6	7	8	9	10

- Column 1 — Self-explanatory.
- Column 2 — Use symbols as appropriate and as shown in column 2 of Appendix B.
- Column 3 — Self-explanatory.
- Column 4 — For TWR and APP only insert information if by regional agreement the requirement is in excess of or less than that specified in Appendix B. For ACC and FIC the area of use of each frequency (i.e. a sector) is best referred to by a number and the area itself should be shown on a chart depicting the area in question in sufficient detail for frequency planning purposes.
- Column 5 — Insert information only if a specific requirement is different from that established by regional agreement.
- Column 6 — Insert the existing assignments, if they have already been made work of frequency assignment planners so that existing assignments of frequencies are respected to the maximum extent possible.
- Column 7 — Indicate whether the assignment is required to satisfy international (INT) or national (NAT) requirements.
- Column 8 — Indicate whether the frequency shown in Column 7 is already in operation (x) or when it is expected that existing or new assignments will be put into operation by year (1985).
- Column 9 — Insert any information which may assist in assessing the planners.
- Column 10 — Reserved for remarks by the frequency assignment planners to indicate that specific requirements cannot be met in technical terms as requested and to propose appropriate alternative.

Chapter 9

Advanced ATS Systems

9.1 INTRODUCTION

9.1.1 Apart from adequate and reliable ground-ground and air-ground communications, an air traffic control (ATC) unit applying conventional control methods has comparatively few requirements for additional means and equipment. Experience has shown that if controllers received adequate training and the social and working conditions are reasonably satisfactory, an ATC unit will be able to handle appreciable amounts of air traffic before it will be necessary to introduce advanced air traffic services (ATS) systems.

9.1.2 While sophisticated equipment will, as a general rule, assist in resolving a particularly pressing problem (primarily capacity limitations), it is also likely that its use will create a number of new problems which, while probably of a less urgent nature, will nevertheless require resolution before the full benefit of the new equipment can be obtained. It has also been found that the introduction of such new equipment does not immediately reduce manpower requirements. In many cases, cost savings on the manpower side, when compared with the increase in air traffic, can only be made once the equipment is used close to its full inherent capacity.

9.1.3 The actual introduction and use of advanced ATS equipment generally requires considerable lead times because of budgetary requirements, administrative arrangements or delays in equipment delivery and/or installation by the supplier. These factors must be weighed against the fact that general progress in the technical field moves quickly and, as a result, advanced ATS equipment is likely to be outdated much earlier than is the case with simpler types of equipment. It must therefore be ensured that new equipment has growth potential to accommodate new steps in technology or the addition of new functions to existing tasks.

9.1.4 The decision to acquire advanced ATS equipment requires careful consideration of all aspects involved, including, where appropriate, detailed review at locations and operating conditions comparable to those where it is intended to be used. Such appraisals will help ensure that

the anticipated benefits will be achieved with a high degree of probability. It may, at times, be advisable to visit locations where such comparable equipment is in operation.

9.1.5 Some of the equipment discussed in this chapter also requires a number of associated actions which, while not directly related to its operation, are nevertheless indispensable if the equipment is to be brought into use in a timely manner (see Part III, Section 1, Chapter 1). The procurement and use of advanced equipment cannot be decided lightly; it requires the development of a complicated and well-programmed multi-disciplinary approach if delays are to be avoided.

9.2 PRIMARY SURVEILLANCE RADAR

9.2.1 The major reason for the provision of primary surveillance radar (PSR) at a specific location is that traffic density and/or complexity has reached a point where, with the application of conventional non-radar control methods only, it is inevitable that aircraft will encounter unacceptable ATC delays. However, since the installation of radar generally presents one of the larger investments and because its recurrent costs are also far from negligible, it is necessary to ascertain that traffic situations which exceed the capacity achievable with conventional control methods are likely to occur reasonably frequently in order to obtain a positive cost-effectiveness equation, once the radar has been installed.

9.2.2 Experience has shown that, with comparatively few exceptions, the decision to provide radar at a given location is based on much more complex considerations than traffic density and/or complexity versus ATC capacity alone. Topography, prevailing weather conditions, civil-military co-ordination arrangements, national security considerations, as well as considerations of an international nature (e.g. gaps in radar coverage in adjacent countries adversely affecting the flow of air traffic over a wide area) can be significant factors in deciding that radar is justified at a

specific location. In the latter case, to obtain full benefits it is especially important that the location of such a radar should not be decided in isolation by the State concerned, but be made the subject of close co-ordination with neighbouring States. Particular points in question are:

- a) the overlap in coverage provided by adjacent radar stations to ensure continuity of radar control between adjacent ATC units;
- b) requirements for uniform performance so that compatible methods of radar control, including agreed separation minima, can be applied between such units.

9.2.3 Due to the inevitable interrelationship between operational desirability and technical limitations (e.g. range versus resolution between targets operating in close proximity to each other and renewal rate of radar data), each radar will most likely be a compromise between what ATC would like to have and what the equipment is capable of furnishing. Therefore, early in the planning process, it will be necessary to establish clear-cut priorities as regards the expected operational performance of the radar so that, once the final choice of the equipment has to be made, it is possible to choose between the essential and the desirable elements of its performance.

9.2.4 The standardization of civil radars, desirable as it may be, must be seen against the fact that, in those States where an electronics industry of sizeable proportions exist, the procurement of such equipment constitutes a very important economic factor. As a consequence, the choice of radar equipment may be dictated by other than technical and operational considerations.

9.2.5 The planning for the provision of radar should always start with the determination of the operational requirements, followed by transformation of these requirements into technical specifications. The ultimate choice of the equipment may, however, also have to take account of other, non-technical, aspects. No hard and fast general rules can be formulated regarding the acquisition of radar equipment. Each case must be considered on its own merits and on the understanding that each party concerned (ATC, the technical services and those responsible for financing and procurement) is given full opportunity to express its views and that the views receive equal and adequate consideration.

9.2.6 The provision of radar in a State is (see Part II, Section 3, Chapter 2) generally done on a progressive basis. It is therefore important that the first installation of such equipment should be seen within an over-all plan which will grow as more radars are provided. Such a plan should form a coherent system of radar coverage throughout the air-

space where such coverage may eventually be required. If this is not done, costly redundancies and/or duplications of equipment might result. In border areas planning will require close co-ordination with neighbouring States so as to avoid costly and unnecessary overlaps of coverage. In some cases, where digitized transmission of radar data from the radar site is used, it may be possible to arrange for sharing of the radar by ATC units located in adjacent States. Such co-ordination may also result in re-delegation of control responsibility, once full radar coverage in the border area is provided (see Annex 11, 2.7).

9.3 SECONDARY SURVEILLANCE RADAR

9.3.1 All of what has been said above with respect to PSR, also applies to secondary surveillance radar (SSR). When fully developed, SSR is a sophisticated and complex co-operative system requiring aircraft to be capable of playing their technical and operational role in the SSR environment (see also Part II, Section 3, Chapter 2).

9.3.2 The decision to use SSR for the provision of ATS requires close co-operation between States and operators concerned if full benefits are to be derived. As to the co-operation with operators, it is evident that, as long as the majority of aircraft operating in the area where SSR is to be applied are not equipped with transponders capable of responding in the manner in which SSR is intended to be used (e.g. 4096 code capability in Mode A/3 plus Mode C), the operational advantage to ATC is substantially reduced. The decision to make the carriage of suitable transponders a mandatory condition for operation in the airspace concerned can have significant and far reaching technical and operational consequences on at least some of the operators concerned.

9.3.3 It will therefore be essential that, when planning for the use of SSR, all aspects of the operation should be taken into account. Operators concerned should be integrated into the planning process from its start, especially as regards:

- a) the manner in which SSR is to be used and the consequent requirements for airborne transponders;
- b) the establishment of realistic target dates for starting the use of SSR in the area concerned;
- c) the related target dates for the mandatory carriage of suitable transponders by all aircraft intending to operate in its area of use, taking due account of lead times required by operators to procure and install such equipment aboard their aircraft;

- d) the development of temporary exemption procedures for those aircraft for which the target date under c) cannot be met and for which a retro-fit is uneconomical because the aircraft useful service life will expire shortly after such a date;
- e) the development of special contingency procedures covering the action to be taken in case of temporary failure of transponders aboard aircraft. Such procedures should not only cover the immediate action to be taken but also the conditions under which aircraft return to their home base in reasonably satisfactory conditions (including flight through airspace where SSR is mandatory, if required) before necessary repairs are made;
- f) the development of procedures regarding the use of SSR alone without the associated PSR.

9.3.4 Co-operation with neighbouring States should not only cover the question of siting and coverage overlap, as already discussed in 9.2.6 above, but also needs to cover mode and frequency co-ordination and the method of code assignment to be used to ensure that the workload on pilots and ATC is kept within reasonable limits.

9.3.5 A further point which needs careful consideration in the planning of SSR is its growth potential both as regards coverage as well as technical sophistication. As described in Part II, Section 3, Chapter 2, SSR equipment can range from comparatively simple ground facilities to very complex arrangements, especially when it is integrated into an automatic ATC system to provide composite synthetic displays with alphanumeric data presentation for individual flights. To avoid expensive replacements of equipment each time a step towards increased sophistication is made, it is necessary to envisage such steps when the basic SSR equipment is procured so that it will be suitable for future expansion.

9.3.6 In those ATC units where SSR has already reached a high degree of development, it has been found that changes to the airspace configuration (ATS routes, routings in terminal control areas (TMAs), reporting points) and/or its designation are more difficult to effect when these configurations are part of the built-in programme of ground equipment. Experience in the European (EUR) region has shown that a change of the system of designation of significant points (i.e. the introduction of name-codes) required postponement for an appreciable period of time because the re-programming of electronically generated video displays and also of the associated flight data processors of the automated equipment required much more time than originally assumed. It would therefore appear that, when considering the use of SSR, airspace configuration changes are scheduled so that appropriate

lead times are provided in order to effect the necessary changes to the software.

9.3.7 Not all aircraft are provided with SSR capability. As a result, it has been considered that the use of SSR without an associated primary radar should be confined to those exceptional cases where it can be ensured that it will not result in unacceptable risks.

9.3.8 As the use of SSR expands and takes account of developments in other fields aimed at the segregation of air traffic according to types of operation (see Part II, Section 4, Chapter 2), it may be possible to arrive at situations where all the traffic, operating within a defined portion of the airspace, i.e. at higher altitudes, will be SSR equipped. If such conditions are created and transponder reliability has reached a point where failures are rare, it may be feasible to rely on SSR without primary radar. Such an arrangement would present a very appreciable economy in the investments required.

9.3.9 It would appear advisable, therefore, to consider the use of SSR alone whenever radar is to be provided in additional portions of the airspace, or in those portions where it is already provided and where primary radar equipment will need replacement. This arrangement would, however, require that information on severe weather phenomena be provided from other sources and superimposed on controllers' displays or shown on a separate display near the controller so that required weather avoidance advice can be given to aircraft.

9.4 AUTOMATION IN ATC

Because of the particularly close interrelationship between the operational requirements and the technical performance resulting from automated equipment, both aspects have been treated together in Part II, Section 3, Chapter 3. However, a number of basic considerations regarding the use of such automated equipment by ATC remain to be discussed.

9.5 FUTURE DEVELOPMENTS

9.5.1 Much has been written about future development in ATC, making the point that ATC cannot and should not be seen in isolation, neither within the field of air navigation, nor in the field of air transport in general. Events since the energy crisis of 1973 have shown that the

previous, nearly unrelated, side-by-side developments of air navigation and air transport are past history and that the economic and technical aspects of civil aviation will have to be treated as an inseparable entity (e.g. user charges versus technical developments in air navigation or fuel economy versus the organization of the traffic flow).

9.5.2 It can be expected therefore that, in the future, technical developments such as requirements for new or additional navigation aids, sophistication of the ATC system by the provision of complex radar and automation equipment, will be measured more severely against the likely economic benefits derived from them rather than what has been the case in the past. More emphasis is likely to be placed on improving available capacities through better procedural arrangements and voluntary co-operation between operators and administrations rather than on the provision of expensive equipment and related manpower which may, in some cases, be required for only comparatively short time periods of peak traffic.

9.5.3 Calculations made in one State (France) have shown that the improvements, required to increase the capacity of the ATC system to a point where it would be able to cope with 99 per cent of the projected demands imposed on its system, would nearly double its annual costs. However, because of the large seasonal and weekly

variations in traffic density in the area in question, the increased capacity thus provided over the existing capacity would only be required 2 to 3 per cent of the total time the ATS system was in operation in the course of a year. The question of the level of capacity to which an ATC system should operate will require more detailed discussion in order that a common policy be established which may serve both States and operators.

9.5.4 In the air navigation field it appears that, within the foreseeable future, a similar process to that already experienced in aircraft development will take place, i.e. that not everything which is technically possible is operationally feasible. However, taking into account the immense variations between States and/or regions in stages of development of the air navigation system in general, the above should not serve as an excuse for not providing those services and facilities which will satisfy those operational requirements which are normally established and agreed upon at regional air navigation meetings of ICAO.

9.5.5 Equipment referred to in this chapter cover the following:

- a) primary surveillance radar;
 - b) secondary surveillance radar;
 - c) electronic data processing equipment (EDP).
-

Chapter 10

Information From Other Sources

10.1 INTRODUCTION

10.1.1 As air traffic services (ATS) is normally the ground service which is in most frequent contact with aircraft, it has been charged with the responsibility of providing pilots with information which, while essential for the safe and efficient conduct of a flight, is not always originated by ATS. ATS depends on certain information derived from other sources; information which is required to permit controllers to assess situations and adjust their actions accordingly. ATS may also serve as the intermediary to obtain information from pilots on actual operating conditions required to complete and/or correct information available to the ground services concerned.

10.1.2 Services most concerned with providing additional information are:

- a) the meteorological service (MET);
- b) the aeronautical information service (AIS);
- c) the aerodrome operating agencies;
- d) the communication services (COM) as regards both the aeronautical mobile service and that dealing with the operation of radio navigation aids.

10.1.3 It will be necessary to conclude arrangements for information with each of the services mentioned above. These arrangements should outline all aspects of co-operation between ATS and the services involved, including responsibility regarding the type of information required, its periodic updating and renewal in case of sudden and significant changes and the format in which the information is to be provided. In the case of renewing information, it is also important that both ATS and the co-operating service concerned are reasonably familiar with each others' operation in order to have a clear understanding of the other duties each of the services is required to perform. This understanding applies particularly to ATS whose primary duties are to provide the required service to aircraft in flight and which, for this reason, must take priority over any other tasks.

10.1.4 Many local factors such as the location of the services in relation to each other, the type and amount of facilities involved, respective responsibilities and reporting lines, etc. are involved in the organization of this collaboration. It is therefore not possible to establish firm, uniform provisions in this field other than to ensure that the information exchange must work with least delay or administrative complications and without friction. It would appear that mutual respect for the other's task can best be fostered by frequent contacts between the personnel directly concerned and close familiarity with their work.

10.2 EXCHANGE OF INFORMATION WITH THE METEOROLOGICAL SERVICE (MET)

10.2.1 The provisions regarding meteorological information required by the different ATS (aerodrome control tower, approach control (APP), area control centre (ACC), flight information centre (FIC)) are contained in Annex 11, Chapter 7. ICAO Doc 9377 — *Manual on Co-ordination between Air Traffic Services and Aeronautical Meteorological Services* also provides pertinent information. However, there are a number of detailed aspects which need consideration in the development of appropriate co-operative arrangements. In the case of relations between a TWR and/or an APP with the local MET service, it is particularly important that provisions regarding assistance to aircraft encountering severe weather phenomena (thunderstorms, hail, etc.), be developed. Such provisions should cover:

- a) the occasions when such data will be required;
- b) the sources from which data on such phenomena will be derived (MET weather radar, ATC radar, pilots' reports);
- c) the manner in which such data will be presented to ATS;
- d) the conditions which will require update or cancellation of previously provided data.

10.2.1.1 Such data as described above should be used by ATS to provide aircraft with information on severe weather sufficiently in advance and should offer routings which will keep aircraft away from areas where the weather persists.

10.2.2 Where necessary because of local conditions, arrangements should also be made between TWRs and APPs and the local MET services which ensure that critical changes in the MET situation (e.g. icing conditions, etc.), which have occurred between the time of the MET briefing of a pilot and his actual departure, are brought to the pilot's attention by the TWR or ACC before take-off so that these changes can be taken into account by the pilot concerned.

10.2.3 As regards the co-operation between ACCs or FICs and the appropriate MET service, the main problem appears to be ensuring that the MET information is provided in meaningful terms and adjusted to the traffic situation with which ACCs and FICs are confronted, i.e. that the information is of interest to both the ACC/FIC and to aircraft because the aircraft are likely to be exposed to the reported conditions. To achieve this, some States have placed MET personnel in ACCs/FICs so they are directly aware of the actual traffic situation and working conditions and can co-ordinate their contributions in the most effective manner. This co-ordination and appreciation also applies whenever the MET services require MET information from aircraft in flight. In other States, other arrangements have been found to also give satisfactory results (intercom lines between MET and ATS, closed circuits, television, etc.). In any case the type and amount of MET information provided should be determined by the needs of operators and pilots and by ATS as far as the information affects the provision of ATS and not by administrative considerations of the MET services only.

10.3 EXCHANGE OF INFORMATION WITH THE AERONAUTICAL INFORMATION SERVICE (AIS)

10.3.1 ATS units must be kept fully informed about the air navigation situation in their own area of responsibility and also in adjacent areas to the extent that such information may have an influence on the flow of air traffic of concern to them (e.g. status of radio navigation aids, military exercises, etc.). It is therefore essential that designated aeronautical information services (AIS) units provide the associated ATS units with the latest infor-

mation available to them. In addition, as regards TWRs and APPs, arrangements should be made which cover those cases where new information has come to hand between the time of pilot briefing by AIS and his departure, which could affect the conduct of his flight in a significant manner and which, therefore, needs to be brought immediately to his attention.

10.3.2 A further point which needs co-operative efforts concerns the manner in which changes to the ATS system requiring NOTAM action should be notified to the AIS unit concerned for the issue of an appropriate NOTAM. Points in question in this respect are:

- a) the contents of the NOTAM;
- b) its expected period of validity;
- c) its editorial arrangement, including the use of the NOTAM code to the maximum extent possible.

10.3.3 Arrangements should also cover the manner in which AIS will participate in the development of material which eventually results in changes to an aeronautical information publication of longer validity (e.g. changes to routings, re-sectorization of ACCs, etc.). To give AIS sufficient lead time in the editorial preparation of the material (e.g. new charts, revised texts) ATS material should be provided well ahead of its date of application (e.g. compliance with the agreed AIRAC cycle).

10.3.4 Appropriate agreements between ATS and AIS units should cover:

- a) the area of interest for which AIS data are required by the ATS unit concerned;
- b) the type of information which is required, especially as regards other areas for which the ATS unit is not directly responsible;
- c) the manner in which such information is to be provided to ATS;
- d) those cases where AIS should notify an aerodrome control tower or APP of a specific change which needs to be brought to the attention of pilots about to take off;
- e) the manner in which ATS will notify AIS on matters which require the issue of a NOTAM or other aeronautical information publication;
- f) the manner in which AIS is to participate in work of ATS which will eventually result in changes requiring the issue of an aeronautical information publication (NOTAM, amendment to the aeronautical information publication (AIP) or Aeronautical Information Circular (AIC)).

10.4 INFORMATION FROM AERODROME OPERATORS

10.4.1 Aerodrome control towers and APPs should be kept currently informed about the status of the aerodromes for which they are providing services. In cases where the ATS and the aerodrome services are provided by the same authority, only appropriate inter-service arrangements are required. However, when the airport authority is a semi-autonomous or completely independent authority, it will be necessary to reach very clear-cut arrangements regarding co-operation and respective responsibilities of ATS and the airport operator. These arrangements should not only cover the exchange of information regarding the status of services and facilities at the aerodrome in question but should also include information on planned or actual maintenance and/or construction work on the air side of the aerodrome, including details of temporary obstructions resulting from such work and affecting the provision of ATS. Such provisions should also cover the manner in which aerodrome services should comply with specific ATS requirements. More obvious cases in question are restoration of faulty visual aids to service, instructions to the fire fighting services when aircraft require their assistance, and other situations such as standby locations for landings under difficult conditions, provision of emergency aid for passengers in a critical situation, special security measures in case of unlawful interference, etc.

10.4.2 Where appropriate, such arrangements should also cover the prompt reporting of runway conditions when water, slush, snow or ice are present and their removal by the speediest means in a manner which interferes least with the actual and/or expected traffic flow.

10.4.3 ACCs and FICs require more general information on the operating status of aerodromes within their area of responsibility. This information should normally be provided to them by the local AIS unit, if one exists at the aerodrome concerned. However, in the case of uncontrolled aerodromes special arrangements will have to be concluded between the ACC/FIC and the aerodrome operators concerned, ensuring the provision and updating of such information in the most suitable manner.

10.4.4 It would also be normal to deal here with the question of visual aids for departure and approach because these aids are in many cases installed and maintained by the aerodrome operator. However, since they are complementary to the non-visual aids serving the same purpose, requirements for information are discussed in 10.5.4 below.

10.5 EXCHANGE OF INFORMATION WITH THE COMMUNICATIONS SERVICES (COM) FIXED AND MOBILE COMMUNICATIONS

10.5.1 ATS units should be kept currently informed about the status of ground-ground communication circuits used by them for ATS purposes. This applies particularly to voice circuits between adjacent ATS units. In case of failure of any of these circuits, the ATS unit should be kept informed by the COM service of the expected time of restoration to full service of the faulty circuit and of alternative means which may be used in the meantime to compensate for the temporary loss of the circuit in question.

10.5.2 Since air-ground communication channels normally come under the complete control of the civil aviation authority, it should be ensured that, apart from timely information on their status, their restoration to full service is given top priority to keep repercussions on the operation of the ATS system as small as possible. Restoration priority also applies to the full or partial failure of recording equipment, used to record telephone and/or radio voice communications.

10.5.3 ACCs and FICs must be provided with current information on the operating status of radio navigation aids used during the en-route phase of flight and in TMAs. Such information is essential to confirm that flights are able to conduct their flight as planned or cleared, except in those cases where individual aircraft encounter failure of their own equipment. It is therefore necessary to provide ACCs/FICs with appropriate control indicators to permit controllers to verify the operating status of the aids with which they are directly concerned. This can be done in a number of ways: one central indicator board showing the over-all situation; individual indicators related to sectors, etc. The arrangement chosen for a particular unit will depend very much on its layout and the working arrangements used. Whatever the arrangement, it must be ensured that such information is readily available, reflects the current situation and is presented so that it is easy to interpret.

10.5.4 As to radio navigation aids and visual aids used for approach and departure, the requirements for immediate and current information are particularly stringent. Detailed specifications regarding this matter have been developed and are contained in Appendix A. Indicators showing the status of these aids should be arranged so that controllers can see with one glance the current status of all the aids serving for approach or departure.

Appendix A

Provision of Information to ATS Units in Respect of Visual and Non-Visual Aids

1. Air traffic controllers and pilots have stringent requirements regarding up-to-date information on the operational status of those non-visual and visual aids which are essential to the departure, approach and landing phases of flight at a given location. The stringency assumes particular significance during weather conditions requiring the conduct of Category II and III approaches. Consequently, it is essential that air traffic controllers be provided with information on any failure of such aids or any degradation of their operational status on a timely basis. The timeliness required for the provision of this information will vary according to the service provided by the ATS unit involved and the use made of the aid(s) involved.
 - 1) the non-visual aids which define those procedures;
 - 2) the operational status of non-visual aids used for initial and intermediate phases of instrument approach procedures for the aerodrome(s) for which it has responsibility;
 - 3) the operational status of visual and non-visual aids used for the final approach and landing phases of instrument approach procedures for the aerodrome(s) for which it has responsibility;
 - 4) the operational status of visual and non-visual aids used for initial track guidance at and immediately following take-off, and those navigation aids used for turning points for instrument departure procedures.
2. The ATS unit will need to be provided an indication of failure or malfunction in a readily intelligible form and without delay. Displays in ATS units should preferably be by remoted indicators rather than by actual monitors. Additionally, the indicators should be located at the ATS working position(s) where the information is needed. The alerting device should give a visual indication to the controller accompanied by an aural alarm of sufficient duration to attract his attention. It is important that the indications reflect the operational status of the aid rather than merely whether or not electrical power is reaching the particular installation.
 - b) An aerodrome control tower requires information on the operational status of visual and non-visual aids used for approach, landing and take-off at the aerodrome with which it is concerned.
 - c) An area control centre which provides clearances to aircraft executing instrument approach procedures and/or instrument departure procedures at aerodromes for which there is no other established ATC unit providing approach control service requires information on the operational status of visual and non-visual aids used for approach, landing, take-off and initial climb at such aerodromes.
 - d) A flight information centre requires information on the operational status of visual and non-visual aids used for approach, landing and take-off at aerodromes within its areas of responsibility for which there is no established ATC unit providing approach control service.
3. The following principles provide general guidance regarding the provision of information to ATS units in respect to visual and non-visual aids:
 - a) An approach control service which employs standard instrument arrival procedures requires information on:
 4. The application of the above principles is shown in the following table.

**Table 1.— Application of the provision of information to
ATS units in respect of visual and non-visual aids**

Principle	Specific phase of operation	Visual and non-visual aid(s) the status of which is important to the ATS unit	Required by which ATS unit	Optimum time requirement
1	2	3	4	5
At locations where approach control service is provided by an approach control office				
A	Inbound on a standard (instrument) arrival procedure	Those VORs and any other NAVAIDs on which the procedure is based	APP	Not more than 2 minutes
B	Initial and intermediate phases of approach	The NAVAID(s) and any secondary aids upon which these phases of the approach are based	APP	Not more than 2 minutes
C	Final approach and landing following an instrument approach	Those aids used for the final approach and landing phases of the approach procedures in use	APP, and TWR if appropriate	Without delay (see note)
D	Take-off and initial climb phases of instrument departure procedure	Those aids used for the runway and departure procedure in use	TWR and/or APP, as appropriate	Without delay (see note)
At locations where approach control service is provided by an area control centre				
E	Approach, landing and take-off	The existing aids of those described in this column for Principles B, C and D	TWR	Same time requirement as listed above for the pertinent principles concerned
F	Approach, landing, take-off and initial climb	The existing aids of those described in this column for Principles B, C and D	ACC (at those locations where there is no TWR)	Not more than 2 minutes
At locations where approach control service is not provided				
G	All phases	All such existing aids	FIC	Not more than 5 minutes

Note.— Reporting requirements to ATS units are specified in Annex 10 for non-visual navigation aids and in Annex 14 for visual aids.

AIR TRAFFIC SERVICES PLANNING MANUAL

PART II

**METHODS OF APPLICATION EMPLOYED BY
AIR TRAFFIC SERVICES**

AIR TRAFFIC SERVICES PLANNING MANUAL

PART II

SECTION 1. AIRSPACE AND TRAFFIC MANAGEMENT

SECTION 1

AIRSPACE AND TRAFFIC MANAGEMENT

Contents

	<i>Page</i>		<i>Page</i>
Chapter 1. Air Traffic Flow Management and Flow Control.....	II-1-1-1	Chapter 2. Co-ordination.....	II-1-2-1
1.1 Introduction	II-1-1-1	2.1 Introduction	II-1-2-1
1.2 Air traffic management (ATM).....	II-1-1-1	2.2 Co-ordination with the military	II-1-2-1
1.2.1 General	II-1-1-1	2.3 Co-ordination with neighbouring States	II-1-2-3
1.2.2 Air traffic services (ATS)	II-1-1-2	2.4 Co-ordination with civil agencies and user organizations	II-1-2-4
1.2.3 Airspace management (ASM).....	II-1-1-2	Appendix A. Civil/military co-ordination of air traffic services in the United States	II-1-2-5
1.2.4 Air traffic flow management (ATFM)	II-1-1-2	Appendix B. Sample letter of agreement between States and ATS authorities	II-1-2-7
1.2.5 Measures to increase ATC capacity	II-1-1-5	Chapter 3. ATS Incident Reporting	II-1-3-1
1.3 Contingency planning	II-1-1-6	3.1 Introduction	II-1-3-1
1.3.1 Introduction	II-1-1-6	3.2 Reporting procedure	II-1-3-1
1.3.2 Status of contingency plans	II-1-1-6	3.2.1 General	II-1-3-1
1.3.3 Responsibility for developing, promulgating and implementing contingency plans	II-1-1-6	3.2.2 Reporting by pilots	II-1-3-2
1.3.4 Preparatory action	II-1-1-7	3.2.3 Reporting by ATS	II-1-3-2
1.3.5 Co-ordination	II-1-1-7	3.3 Investigation and documentation	II-1-3-2
1.3.6 Development, promulgation and application of contingency plans	II-1-1-8	3.4 Analysis of ATS incidents	II-1-3-3
Appendix A. Application of automation in air traffic flow management	II-1-1-9	3.5 Release of information	II-1-3-4
Appendix B. Examples of typical messages for the control of air traffic flow	II-1-1-11	Appendix A. Air traffic incident report form	II-1-3-5
Appendix C. Techniques for ATC sector/position capacity estimation	II-1-1-12	Chapter 4. ATS Evaluation	II-1-4-1
		4.1 Introduction	II-1-4-1
		4.2 Purpose and scope of evaluation	II-1-4-1
		4.3 Conduct of evaluation	II-1-4-1
		4.4 Documentation	II-1-4-2

Chapter 1

Air Traffic Flow Management and Flow Control

1.1 INTRODUCTION

1.1.1 The objective of air traffic flow management (ATFM) service is to ensure an optimum flow of air traffic to or through areas during times when demand exceeds, or is expected to exceed, available capacity of the air traffic control (ATC) system. The term ATFM is used to embrace any activity concerned with the organization and handling of the flow of air traffic in such a way that, while ensuring the safe, orderly and expeditious flight of individual aircraft, the totality of the traffic handled at any given point or in any given area is compatible with the capacity of the air traffic control system. The term ATC capacity reflects the ability of the ATC system or any of its sub-systems or operating positions to provide service to aircraft during normal activities, and is expressed in numbers of aircraft entering a specified portion of the airspace in a given period of time. The maximum peak capacity which may be achieved for short periods may be appreciably higher than the sustainable capacity. ATFM supports ATC in meeting its main objectives of preventing collisions between aircraft, expediting and maintaining an orderly flow of air traffic, as well as of achieving the most efficient utilization of available airspace and airport capacity. To be effective, an ATFM service must have continuous co-operation and co-ordination with participating ATC units and the various airspace users.

1.1.2 In their planning and management of airspace, States should aim to promote flight safety, provide sufficient capacity to meet normal traffic demands, ensure maximum utilization of airspace, ensure compatibility with international developments, and balance the legitimate, but sometimes conflicting, requirements of all users. Airspace management (ASM) should be aimed at the most effective exploitation of the airspace in accordance with the requirements of the various airspace users. In some cases of conflicting requirements, segregation of airspace in general may be the only feasible air traffic management solution. However, in order to make maximum use of airspace, more civil/military co-ordination must be achieved, with airspace being shared, either simultaneously or on a time-share basis, taking into account the different levels of aircraft equipage and the various ATC components.

1.1.3 The most efficient utilization of available airspace and airport capacity can be achieved only if all relevant elements of the air traffic system had been considered during the planning stage, applying a systems approach. The flow of traffic is hampered by bottlenecks in the system; a constraint anywhere in the system will contribute to capacity limitations. For that reason, neither the airport system nor the air navigation system should be considered separately in planning system improvements.

1.1.4 Present-day airspace utilization is not seen as being "optimal" and/or "flexible" in the broadest sense because of the existing discrepancy between ATC capacity and users' demands, particularly during peak traffic periods. The inflexibility often associated with the present fixed route structure prevents the most efficient use of the airspace and the most economical conduct of flight operations. Shortcomings in communications, navigation and surveillance (CNS) systems, as well as the lack of harmonized system developments, are also identified as contributing factors to the current system shortcomings. The limited level of co-operative planning has led to, *inter alia*, duplication of facilities across national boundaries, limited sharing of radar data, significant variations in the application of separation minima, cumbersome ATC co-ordination procedures and the application of different cruising level systems. These shortcomings may result in delays or re-routing of the traffic, adversely affecting the regularity and economy of flights. In order to accommodate the growth of air traffic, an appropriate plan for air traffic management (ATM) should be established, aimed at optimizing the airspace utilization as well as maintaining an orderly flow of the air traffic.

1.2 AIR TRAFFIC MANAGEMENT (ATM)

1.2.1 General

1.2.1.1 The Special Committee on Future Air Navigation Systems (FANS) described ATM as consisting of a ground part and an air part, both of which are needed to ensure the safe and efficient movement of aircraft during all phases

of operation. The execution of ATM calls for a close integration of the ground part and the air part through well-defined procedures (FANS(II)/1 (yellow cover report), 6.3 refers).

1.2.1.2 The general objective of ATM, as described by FANS, is to enable aircraft operators to meet their planned times of departure and arrival and adhere to their preferred flight profiles with minimum constraints and without compromising agreed levels of safety.

1.2.1.3 The airborne part of ATM, according to FANS, consists of the functional capability which interacts with the ground part to attain the general objectives of ATM. The ground part of ATM comprises the functions of air traffic services (ATS), airspace management (ASM) and air traffic flow management (ATFM). The air traffic services are the primary components of ATM.

1.2.2 Air traffic services (ATS)

1.2.2.1 *Air traffic control (ATC)*. The main objectives of the air traffic control service are to prevent collisions between aircraft and between aircraft and obstructions in the manoeuvring area and to expedite and maintain an orderly flow of air traffic. These objectives can be achieved by applying separation between aircraft and by issuing clearances to individual flights as close as possible to their stated intentions, taking into account the actual state of airspace utilization and within the general framework of measures for the control of air traffic flow when applicable.

1.2.2.2 *Flight information service (FIS)*. The objective of the flight information service is to provide advice and information useful for the safe and efficient conduct of flights.

1.2.2.3 *Alerting service*. The purpose of the alerting service is to notify appropriate organizations regarding aircraft in need of search and rescue aid and assist such organizations as required.

1.2.3 Airspace management (ASM)

1.2.3.1 The objective of ASM is to maximize, within a given airspace structure, the utilization of available airspace by dynamic time-sharing and, at times, segregation of airspace among various categories of users based on short-term needs. Close co-operation between the appropriate authorities on expected and actual utilization of the temporary reserved airspace should result in

information being readily available to all parties concerned, i.e. commercial air transport, military operational air traffic and general aviation. ASM is also an adjunct to ATC, as is ATFM.

1.2.3.2 In order to accomplish the above-mentioned ASM objective, the following functions are necessary:

- a) collection and evaluation of all requests which require temporary airspace allocation;
- b) planning and allocation of the required airspace to the users concerned where segregation is necessary;
- c) activation or de-activation of such airspace within adequately narrow time tolerances, in close co-operation with ATC units and civil or military units concerned. The additional route mileage flown by civil aircraft to avoid airspace exclusively reserved for military activities indicates a need for more effective civil/military co-ordination. The dimensions, positioning, requirements and use of reserved airspace, danger areas and restricted areas should remain under close scrutiny, and a more efficient utilization of airspace encouraged by minimizing the hours of such activities. The usage of military training areas should also be considered. Every effort should be taken to open up such areas to civil operations whenever operational circumstances permit; and
- d) dissemination of detailed information, both in advance and in real time, to all parties concerned.

1.2.3.3 Information on the status of airspace should be available to the ATFM service.

1.2.4 Air traffic flow management (ATFM)

1.2.4.1 As indicated in 1.1.1 above, ATFM service is established to support ATC in ensuring an optimum flow of air traffic to, from, through or within defined areas during times when demand exceeds, or is expected to exceed, the available capacity of the ATC system, including relevant aerodromes. ATFM should be developed as necessary to ensure this optimum flow.

1.2.4.2 An optimum flow of air traffic is not always possible due to various constraining factors, such as conflicting users' requirements, air navigation system limitations and unexpected weather conditions. In this connexion, alleviating measures, such as control of air traffic flow, will need to be considered, particularly when the ATC system can no longer fully cope with the volume of air traffic. Such measures frequently result in delays of flights prior to departure, in-flight holdings, use of uneconomic flight levels, re-routing and diversions,

disruptions of flight schedule, economic and fuel penalties for aircraft operators, congestion on aerodromes or in terminal buildings and passenger dissatisfaction.

1.2.4.3 It should be noted that the control of air traffic flow is specified in Annex 11, 3.7.4, as follows:

“When it becomes apparent to an air traffic control unit that traffic additional to that already accepted cannot be accommodated within a given period of time at a particular location or in a particular area, or can only be accommodated at a given rate, that unit shall advise other air traffic control units and operators known or believed to be concerned and pilots-in-command of aircraft destined to that location or area that additional flights are likely to be subjected to excessive delay, or, if applicable, that specified restrictions are to be applied to any additional traffic for a specified period of time for the purpose of avoiding excessive delay to aircraft in flight.”

1.2.4.4 The main causes of the air traffic congestion are:

- a) accumulation of air traffic during specific periods of the year and also during certain times of the week and hours of the day, due to holiday patterns and travel habits of the public;
- b) differences in the capacities of the various ATC systems or parts of these systems affected by traffic accumulations;
- c) insufficient advance notice (to ATC units) of likely traffic demands which may cause overloading of the system at certain points, in certain areas, and/or during specific time periods; and
- d) lack of proven techniques and procedures to restore, in critical situations, a reasonable balance between traffic demand and available ATC capacity by means acceptable to aircraft operators both from an operational and from an economic point of view.

1.2.4.5 The accumulation of air traffic may be due to the fact that operators adapt their services to their customers' demand and that the choice of routes and flight levels is limited, due to the need to share the airspace with other users, especially the military. In addition, operators may have to cope with restrictions imposed on them for environmental reasons, i.e. night curfews at aerodromes, noise abatement procedures, etc., which tend to concentrate the traffic in a narrow period of time.

1.2.4.6 The traffic handling capacities of ATC systems may be inadequate as a result of insufficient staffing of existing facilities, in terms of either the number of personnel or their qualifications. Inefficient ATC

procedures may also limit ATC capacity, e.g. inadequate liaison and/or lack of letters of agreement between States, especially those relating to transfer of control of aircraft between adjacent States. Furthermore, lack of ATC equipment such as primary and secondary surveillance radar and electronic data processing equipment may cause difficulties in coping with the growth of air traffic.

1.2.4.7 Measures to control the flow of air traffic will need to be taken in certain cases to ensure a reasonable balance between the air traffic demand and the ability of the air traffic services to accommodate that demand. However, it should be emphasized that these measures are restrictive in nature and should be kept to the minimum and, whenever possible, be applied selectively so as to affect only that part of the over-all air traffic which causes the problem. The term “selectively” should not permit the use of any discriminatory practices by the ATC unit concerned. Any distinction between different parts of the air traffic should be based exclusively on categories such as arriving or departing air traffic or overflights, without any consideration of the type of flights (civil, military, scheduled, non-scheduled, etc.). When flow control measures are necessary for certain areas, they should be applied only for the period when expected air traffic demand will exceed the capacity in those areas. Flow control measures should be established and co-ordinated in such a way that they will not cumulatively interact with each other on the same flights.

1.2.4.8 In the context of ATFM, the following types of flights should be granted exemption from flow control measures:

- a) flights in a state of emergency, including flights subjected to unlawful interference;
- b) flights operating for humanitarian reasons;
- c) medical flights specifically declared by medical authorities;
- d) flights on search and rescue missions;
- e) flights with “Head of State” status*; and
- f) other flights as specifically required by State authorities*.

1.2.4.9 In co-operating with ATC and aircraft/aerodrome operators to balance traffic demand and the capability of ATC to safely accommodate that demand, the ATFM service should permit full exploitation of ATC capacity, maximum flexibility in the use of the route structure to

* There may be occasions when, due to the number of priority aircraft involved (for example, meetings of Heads of States), it will be necessary to issue delays to such aircraft to ensure that safe handling capacity figures are not exceeded.

secure minimum delay for all flights and orderly distribution of traffic flows, while giving appropriate consideration to operators' requirements. Furthermore, advance information on overload situations should be provided to ATC and aircraft/aerodrome operators, and relevant air traffic statistics should be generated in order to promptly identify the bottlenecks in the system. It should be emphasized at this point that the successful implementation of ATFM and flow control will depend on the effectiveness of the communication and co-operation established among national ATS authorities, aircraft operators, controllers and military authorities.

1.2.4.10 The ATFM service should fulfil the following basic strategic and tactical functions:

- a) collection and collation of data on the air navigation infrastructure and on the capacities of the ATC system and selected aerodromes within the "ATFM area", including runway, taxiway and gates capacities. This embraces those areas in which traffic flow problems are likely to be encountered;
- b) collection and analysis of data for all planned controlled flight operations into, out of, within and through the ATFM area;
- c) determination of a coherent picture of expected traffic demand, including anticipated *ad hoc* traffic, comparison with available capacity and identification of areas and time periods of expected critical traffic loadings;
- d) co-ordination with the appropriate ATS authorities in order to make every possible attempt to increase the available ATC capacity where required. In some particular situations it could be advantageous for national and local scheduling committees to be established, with representatives from national ATS, airport authorities, national and international operators. Such committees can make significant contributions when developing strategies to reduce the impact of peak demand periods; and
- e) where ATC capacity shortfalls cannot be eliminated, determination and implementation in good time of suitable tactical measures co-ordinated throughout the ATFM area as necessary and with aircraft/aerodrome operators concerned.

1.2.4.11 Whenever measures to control the flow of air traffic have to be applied in the form of delays, they should, if possible, be applied by ATC to aircraft on the ground rather than to aircraft in flight. Whenever application of such measures in the form of delays to airborne aircraft becomes unavoidable, the flights concerned should be informed as soon as possible. Whenever en-route holding becomes necessary, the aircraft concerned should be held as

closely as practicable to the entry point of the area causing the restrictions.

1.2.4.12 The introduction of flow control measures requires that the air traffic system capacity be accurately determined and an assessment made of the level of traffic demand above which the traffic flow will require regulation. Having determined this level, ATFM should provide the area control centre (ACC) serving a terminal area with information on an hour-to-hour basis (and to the best accuracy possible) regarding the planned times of arrival and departure of all aircraft during each period (15 or 30 minutes) when peak traffic conditions may be expected. Preferably, such predictions should be prepared three hours or more in advance and reviewed and revised periodically thereafter. Since such predictions require information on many aircraft that have not yet taken off or are otherwise not known to the ACC, special arrangements must be made by the ATFM to obtain this information from adjacent ACCs, the operators and/or other sources such as repetitive flight plans. Predicting the capacity of the system starts from a knowledge of capacity available under optimum operating conditions. It is then necessary to make allowance for adverse weather conditions, runway configurations at destination and the effect of forecast wind shift, runway unserviceability, inoperative en-route navigation and/or landing aids or any other factor which could adversely affect flight regularity. This information is then assessed by the ATFM service, in close co-operation with ATC, so as to arrive at a probable capacity figure for the system at any given time.

1.2.4.13 Measures to regulate demand may take several forms. In simpler systems, ACCs exercising flow control to surrounding area control centres disseminate notices requesting that affected aircraft be spaced at prescribed intervals, e.g. one every ten minutes. Spacing of aircraft for flow control purposes should not be mixed with separation, but rather should be based on an "acceptance rate", i.e. the number of aircraft accepted in a given period of time. This method of applying flow control is used by a number of ACCs without computer assistance. An improved and more sophisticated form of regulation of arrivals is possible with automated ATC systems, in which the controller is provided with computer assistance in the sequencing and spacing of aircraft in the terminal area. In this case, calculation of the delays which are caused by the sequencing and spacing operation can be transformed into clearances requiring aircraft to operate at reduced speed while still en route to the terminal area. Operation at reduced speed will enable aircraft concerned to absorb at least some of the delay while still en route. Reduced power settings may also be attractive to operators because of the consequent fuel savings. It should be noted, however, that

reduced speed en route can frequently increase congestion in the en route segment and lead to increased sector complexity because of the incompatibility of speeds at the same flight level.

1.2.4.14 It should be noted that new technology in exploiting automation by means of aircraft situation display (ASD) is currently being used by the United States Federal Aviation Administration (FAA) to handle ATFM for both strategic and tactical purposes. A description of this implementation is contained in Appendix A.

1.2.4.15 Well before the application of flow control restrictions, predictions of the expected demand should be used to inform operators and pilots of anticipated delays. This advice should be widely disseminated, either by aeronautical fixed telecommunication network (AFTN) or voice circuits, alerting the aircraft/aerodrome operators to such delays, as well as to any diversions which may be required. Such notices can often reduce or even postpone the need for flow control restrictions. Appendix B outlines examples of typical messages for the control of air traffic flow.

1.2.4.16 Air traffic flow management cannot be restricted to the area of one State because of its far-reaching effects on the flow of air traffic elsewhere. Optimum flow of air traffic could be best achieved through an integrated central air traffic flow management service using internationally agreed procedures with a view to maintaining, in continuous co-operation with associated ATC units and operators, a balance between a traffic demand and the capability of ATC to accommodate that demand. Detailed information covering the objectives, organization and operation of centralized ATFM organization (CTMO) is contained in the Air Navigation Plan — European Region (Doc 7754, Part V — ATM) and the European ATFM Handbook, Provisional Edition, 1991 (ICAO EUR Doc 003).

1.2.5 Measures to increase ATC capacity

1.2.5.1 It will become apparent that the ATC system is approaching saturation when high traffic density prevails, accompanied by continuing and more frequent delays or disruptions of service which become increasingly difficult to resolve. Relief from the problem can be obtained by:

- a) taking all reasonable steps to fully exploit the existing capacity of the air navigation system;
- b) developing plans to increase the capacity of the ATC system where required, particularly in the terminal airspace, so as to be able to meet the forecast traffic demand of the users. Such plans should take account of

the need for effective SIDs and STARs, development of segregated VFR and IFR routes, assessment of impact of noise abatement procedures and curfew windows, development of procedures to accommodate emergency situations, etc.;

- c) negotiating letters of agreement between adjacent States to ensure the development of proper procedures for co-ordination and transfer of control. In this context, efforts should be made where possible and practicable to design sectorization independently of artificial boundaries, such as existing borders;
- d) developing procedures between units to improve flow management to make maximum use of the available ATC capacity;
- e) ensuring that new measures to be adopted are introduced with minimum delay and preferably simultaneously by adjacent units;
- f) designing ATC procedures for handling arriving aircraft in order to provide the best exploitation of available runways and landing capacity. This should be achieved in conjunction with the users' requirements for optimum descent and direct path; and
- g) achieving efficient arrival/departure operations through improved runway/taxiway design, such as the provision of parallel taxiways and high-speed runway exits.

1.2.5.2 A necessary capacity assessment should be made by methods yielding realistic results which should be expressed in terms which make capacity values comparable. These should preferably be stated as the number of aircraft which may enter a given volume of airspace within a given period of time. Appendix C contains a summary of techniques for ATC sector/position capacity estimation which focuses on the tasks carried out by the air traffic controller. The workload of the controller is estimated by summing the time spent on individual tasks.

1.2.5.3 The air traffic demand to be accommodated by the air navigation system should be described in such terms that it can be directly compared with the capacity of that system or its affected components. A detailed traffic forecast regarding major traffic flows in a particular flight information region (FIR) or area composed of several FIRs should be prepared. Such forecasts should be used to determine the development of airspace and flow management as far ahead as possible and for a period of at least five years and in such a form that it can be used by all concerned with the planning of the air navigation system. They should indicate both average traffic demand and peak values, as well as seasonal, weekly or diurnal changes in future traffic demand. States should continuously review the capacity of their ATC system in order to ensure that it can be adjusted to accommodate forecast traffic demands.

1.3 CONTINGENCY PLANNING

1.3.1 Introduction

1.3.1.1 Guidelines for contingency measures for application in the event of disruptions of air traffic services and related supporting services have been approved by the Council in response to Assembly Resolution A23-12 following a study by the Air Navigation Commission and consultation with States and international organizations concerned, as required by the Resolution. Their purpose is to assist in providing for the safe and orderly flow of international air traffic in the event of disruptions of air traffic services and related supporting services and in preserving the availability of major world air routes within the air transportation system in such circumstances.

1.3.1.2 The guidelines have been developed in recognition of the fact that circumstances before and during events causing disruptions of services to international civil aviation, vary widely and that contingency measures, including access to designated aerodromes for humanitarian reasons, in response to specific events and circumstances must be adapted to these circumstances. They set forth the allocation of responsibility among States and ICAO for the conduct of contingency planning and the measures to be taken into consideration in developing, applying and terminating the application of such plans.

1.3.1.3 The guidelines are based on experience which has shown, *inter alia*, that the effects of disruption of services in particular airspaces are likely to significantly affect the services in adjacent airspaces, thereby creating a requirement for international co-ordination — hence the role of ICAO in the field of contingency planning and co-ordination of such plans, as defined by the guidelines. They also reflect the experience that ICAO's role in contingency planning must be global and not limited to airspaces over the high seas and areas of undetermined sovereignty, if the availability of major world air routes within the air transportation system is to be preserved. Finally, they further reflect the fact that international organizations concerned such as the International Air Transport Association (IATA) and the International Federation of Airline Pilots' Associations (IFALPA) are valuable advisors on the practicability of over-all plans and elements of such plans.

1.3.2 Status of contingency plans

Contingency plans are intended to provide alternative facilities and services to those provided for in the regional

air navigation plan when those facilities and services are temporarily not available. Contingency arrangements are therefore temporary in nature, remain in effect only until the services and facilities of the plan are re-activated and, accordingly, do not constitute amendments to the regional plan requiring processing in accordance with the "Procedure for the Amendment of Approved Regional Plans".

1.3.3 Responsibility for developing, promulgating and implementing contingency plans

1.3.3.1 The State(s) responsible for providing air traffic services and related supporting services in particular portions of airspace is (are) also responsible, in the event of disruption or potential disruption of these services, for instituting measures to ensure the safety of international civil aviation operations and, where possible for making provisions for alternative facilities and services. To that end the State(s) shall develop, promulgate and implement appropriate contingency plans. Such plans shall be developed in consultation with other States concerned and with ICAO, as appropriate, whenever the effects of the service disruption(s) are likely to affect the services in adjacent airspaces.

1.3.3.2 The responsibility for appropriate contingency action in respect of airspace over the high seas continues to rest with the State(s) normally responsible for providing the services until, and unless, that responsibility is temporarily reassigned by ICAO to (an)other State(s).

1.3.3.3 Similarly, the responsibility for appropriate contingency action in respect of airspace where the responsibility for providing the services has been delegated by another State, continues to rest with the State providing the services until, and unless, the delegating State terminates temporarily the delegation. Upon termination, the delegating State assumes responsibility for appropriate contingency action.

1.3.3.4 ICAO will assume the responsibility for initiating and co-ordinating appropriate contingency action in the event of disruption of air traffic services and related supporting services affecting international civil aviation operations provided by a State wherein, for some reason, the authorities cannot adequately discharge the responsibility referred to in 1.3.3.1 above. In such circumstances, ICAO will work in co-ordination with States responsible for airspaces adjacent to that affected by the disruption and in close consultation with international organizations concerned. ICAO will assume the same responsibility at the request of States.

1.3.4 Preparatory action

1.3.4.1 Time is essential in contingency planning if hazards to air navigation are to be reasonably prevented. Timely introduction of contingency arrangements requires decisive initiative and action, which again presupposes that contingency plans have, as far as practicable, been completed and agreed among the parties concerned before the occurrence of the event requiring contingency action, including the manner and timing of promulgating such arrangements.

1.3.4.2 For the reasons given in 1.3.4.1 States should take preparatory action, as appropriate, for facilitating timely introduction of contingency arrangements. Such preparatory action should include:

- a) preparation of general contingency plans for introduction in respect of generally foreseeable events such as industrial action or labour unrest affecting the provision of air traffic services and/or supporting services. In recognition of the fact that the world aviation community is not party to such disputes, States providing services in airspace over the high seas or of undetermined sovereignty should take appropriate action to ensure that normal air traffic services will be provided to international civil aviation operations in non-sovereign airspace. For the same reason, States providing air traffic services in their own airspace or, by delegation, in the airspace of (an)other State(s) should take appropriate action to ensure that normal air traffic services will be provided to international civil operations concerned, which do not involve landing or take-off in the State(s) affected by industrial action;
- b) monitoring of any developments which might lead to events requiring contingency arrangements to be developed and applied. States should consider designating persons/administrative units to undertake such monitoring and, when necessary, to initiate effective follow-up action;
- c) designation/establishment of a central agency which, in the event of disruption of air traffic services and introduction of contingency arrangements, would be able to provide during the 24 hours of the day, up-to-date information on the situation and associated contingency measures until the system has returned to normal. A co-ordinating team should be designated within or in association with such a central agency for the purpose of co-ordinating activities during the disruption.

1.3.4.3 ICAO will be available for monitoring developments which might lead to events requiring contingency arrangements to be developed and applied. During the

emergence of a potential crisis a co-ordinating team will be established in the Regional Office(s) concerned and at ICAO Headquarters in Montreal and arrangements will be made for competent staff to be available or reachable throughout the 24 hours of the day. The tasks of these teams will be to monitor continuously information from all suitable sources, arrange for the constant supply of relevant information received by the State AIS service at the location of the Regional Office and Headquarters, liaise with international organizations concerned and their regional organizations, as appropriate, and exchange up-to-date information with States directly concerned and States which are potential participants in contingency arrangements. Upon analysis of all available data, authority will be obtained for initiating the action required in the circumstances.

1.3.5 Co-ordination

1.3.5.1 A contingency plan must be acceptable to providers and users of contingency services alike, i.e. in terms of the ability of the providers to discharge the functions assigned to them and in terms of safety of operations and traffic handling capacity provided by the plan in the circumstances.

1.3.5.2 Accordingly, States which anticipate disruption of air traffic services and/or related supporting services, should advise as early as practicable, the ICAO Representative accredited to them and other States whose services might be affected. Such advice should include information on associated contingency measures or a request for assistance in formulating contingency plans.

1.3.5.3 Detailed co-ordination requirements should be determined by States and/or ICAO, as appropriate, keeping the above in mind. In the case of contingency arrangements not appreciably affecting airspace users or service provided outside the airspace of the (single) State involved, co-ordination requirements are naturally few or non-existent. Such cases are believed to be few.

1.3.5.4 In the case of multi-State venture, detailed co-ordination leading to formal agreement of the emerging contingency plan should be undertaken with each State which is to participate. Such detailed co-ordination should also be undertaken with those States whose services will be significantly affected, for example by re-routing of traffic, and with international organizations concerned who provide invaluable operational insight and experience.

1.3.5.5 Whenever necessary to ensure orderly transition to contingency arrangements, the co-ordination referred to

in this Section should include agreement on a detailed, common NOTAM text to be promulgated at a time to be notified by a special agreed message.

1.3.6 Development, promulgation and application of contingency plans

1.3.6.1 Development of a sound contingency plan is dependent upon circumstances, including the availability or not for use by international civil aviation operations, of the airspace where services have been disrupted. Sovereign airspace can be used only on the initiative of or with the agreement or consent of the authorities of the State concerned regarding such use. Otherwise, the contingency arrangements must involve bypassing the airspace, and should be developed by adjacent States or by ICAO in co-operation with such adjacent States. In the case of airspace over the high seas or of undetermined sovereignty, development of the contingency plan might, depending upon circumstances, including the degree of erosion of the alternative services offered, involve temporary re-assignment by ICAO of the responsibility for providing air traffic services in the airspace concerned.

1.3.6.2 Development of a contingency plan presupposes as much information as possible on current and alternative routes, navigational capability of aircraft and availability or partial availability of navigational guidance from ground based aids, communications capability of adjacent air traffic services units, volume and types of aircraft to be accommodated and the actual status of the air traffic services, communications, meteorological and aeronautical information services. Following are the main elements to be considered for contingency planning depending upon circumstances:

- a) re-routing of traffic to avoid the whole or part of the airspace concerned, normally involving establishment of additional routes with associated conditions for their use;
- b) establishment of a simplified route network through the airspace concerned, if it is available, together with a flight level allocation scheme to ensure lateral and vertical separation and a procedure for adjacent area control centres to establish longitudinal separation at entry point and to maintain such separation through the airspace;

- c) re-assignment of responsibility for providing air traffic services in airspace over the high seas or in delegated airspace;
- d) provision and operation of adequate air-ground communications, AFTN and ATS direct speech links, including reassignment to adjacent States of the responsibility for providing meteorological information and information on navigation aids;
- e) special arrangements for making, collecting and disseminating in-flight and post-flight reports from aircraft;
- f) a requirement for aircraft to maintain continuous listening watch on a specified pilot-pilot VHF frequency in specified areas where air-ground communications are uncertain or non-existent and to broadcast, preferably in English, position information and estimates on that frequency, including start and completion of climb and descent;
- g) a requirement for all aircraft in specified areas to display navigation and anti-collision lights at all times;
- h) a requirement and procedures for aircraft to maintain their own longitudinal separation from preceding aircraft at the same cruising level;
- i) a requirement for climbing and descending well to the right of the centre line of specifically identified routes;
- j) establishment of arrangements for controlled access to the contingency area to prevent overloading of the contingency system;
- k) a requirement for all operations in the contingency area to be conducted in accordance with IFR, including allocation of IFR flight levels from the Table of Cruising Levels in Appendix 3 of Annex 2 of ATS routes in the area.

1.3.6.3 Notification by NOTAM to users of air navigation services of anticipated or actual disruption of air traffic services and/or related supporting services shall be dispatched as early as practicable. The NOTAM shall include the associated contingency arrangements. In the case of foreseeable disruption, the advance notice shall in any case not be less than 48 hours.

1.3.6.4 Notification by NOTAM of discontinuance of contingency measures and re-activation of the services set forth in the regional air navigation plan shall be dispatched as early as required to ensure an orderly transfer from contingency conditions to normal conditions.

Appendix A

Application of Automation in Air Traffic Flow Management

1. BACKGROUND

The United States Federal Aviation Administration (FAA) has introduced an enhanced traffic management system (ETMS) which is uniquely serving the nation-wide needs of the FAA traffic management system. The Transportation System Centre (TSC) of the Department of Transportation developed the system which exploited state-of-the-art technology and pioneered automation concepts. An essential part of the ETMS is an innovative aircraft situation display (ASD) which depicts current aircraft positions of all en-route aircraft under instrument flight rules (IFR) being controlled by the existing twenty air route traffic control centres (ARTCCs). The ASD has a highly valued capability for graphically displaying current aircraft positions on a national scale, superimposed on maps on geographical boundaries and national airspace system (NAS) facilities. The ASD was installed in the FAA central flow control facility (CFCF), now designated air traffic system command centre (ATSCC), in 1987; in the Los Angeles, Chicago and New York ARTCCs in 1988; followed by the remainder of the twenty ARTCCs and selected terminal radar approach control (TRACON) facilities. The second ETMS phase adds the monitor and alert (MA) function, which provides the capability for projecting traffic demands for all airports, sectors and fixes of interest in the continental United States, and automatically alerts traffic managers of predicted congestion. The third phase of the ETMS development includes automated demand resolutions (ADR), offering alternative solutions to predicted problems. The traffic managers will be able to optionally select from among these alternatives to resolve airport and en-route congestion and delay problems. The fourth phase of development includes substantial expert system components to evaluate the alternative resolutions generated from the third phase function and recommend the best solution for the air traffic managers' approval. The fifth and final phase of the ETMS involves the addition of the necessary automation support for future traffic management needs.

2. DESCRIPTION AND OBJECTIVE OF AIRCRAFT SITUATION DISPLAY (ASD)

2.1 The main objective of ASD is to enable the ATSCC to manage the flow of air traffic throughout the United States national airspace system for both strategic and tactical purposes. The ASD provides the ATSCC and each ARTCC with an accurate air traffic flow and weather information picture across continental United States in real time. Through ASD, the traffic management unit (TMU) in each ARTCC can, in continuous co-ordination with ATSCC by telephone conferences (TELCONS), initiated daily by the latter, decide when, where and for how long, flow control restrictions are required to handle any inbound congestion problems or to implement severe weather avoidance plans (SWAP).

2.2 The ASD depicts the current aircraft positions of all controlled en-route IFR flights (updated on a three-minute cycle), and presents the traffic managers with a timely and accurate picture of the en-route NAS traffic flows. The ASD has many features designed to assist the traffic manager in assimilating details of complex traffic situations and to highlight specific flights of interest to assist in resolving congestion problems. The ASD can zoom in and out in numerous steps from continental United States scale (about 3 000 NM horizontal scale) to a sub-sector scale of 20 NM across. Specific aircraft can be identified by data blocks containing aircraft identification, altitude, aircraft type, estimated time to destination, ground speed and origin/destination airports. The ASD can further depict the intended route of flights (as dashed line segments) showing all en-route turning points. To aid in highlighting groups of flights, traffic managers can choose to filter out flights, turn on data blocks, or change aircraft colours by any number of selection factors such as origin, destination, transit sector, airway, fix, aircraft type and altitude range

(see Figure 1). To aid in examining past traffic flow, the ASD has a replay capability. Live weather observations and forecasts are also accessible in real time via the ASD for assessing air traffic and NAS capacity impacts. A major function which was added to the ASD in June 1988 was the monitor and alert capability. The monitor/alert (MA) function automatically displays the predicted air traffic congestion problems for airports, sectors and fixes. Shown as red highlighted overlays on the ASD screen, the problem areas can be scrutinized by calling up detailed bar charts of demand versus alert thresholds, listings of involved aircraft, and displays of the specific flights for a selected fifteen-minute problem interval. This alert function is automatically updated on a five- to ten-minute basis. The predictions, based upon flight schedules, individual flight

plans and actual flight position reports, extend several hours into the future.

2.3 The use of live flight information and weather forecasts led to a high degree of confidence in the system for its use in the co-operative activities between authorities concerned with planning and organizing the most effective use of the airspace and air traffic flows, i.e. the central air traffic management executive unit, the various area control centres and the aircraft/aerodrome operators. The advanced traffic management automation programme described above is instrumental in evaluating air traffic and weather-related congestion problems and assists the users in optimizing and rationalizing the ATFM service through a structured approach.

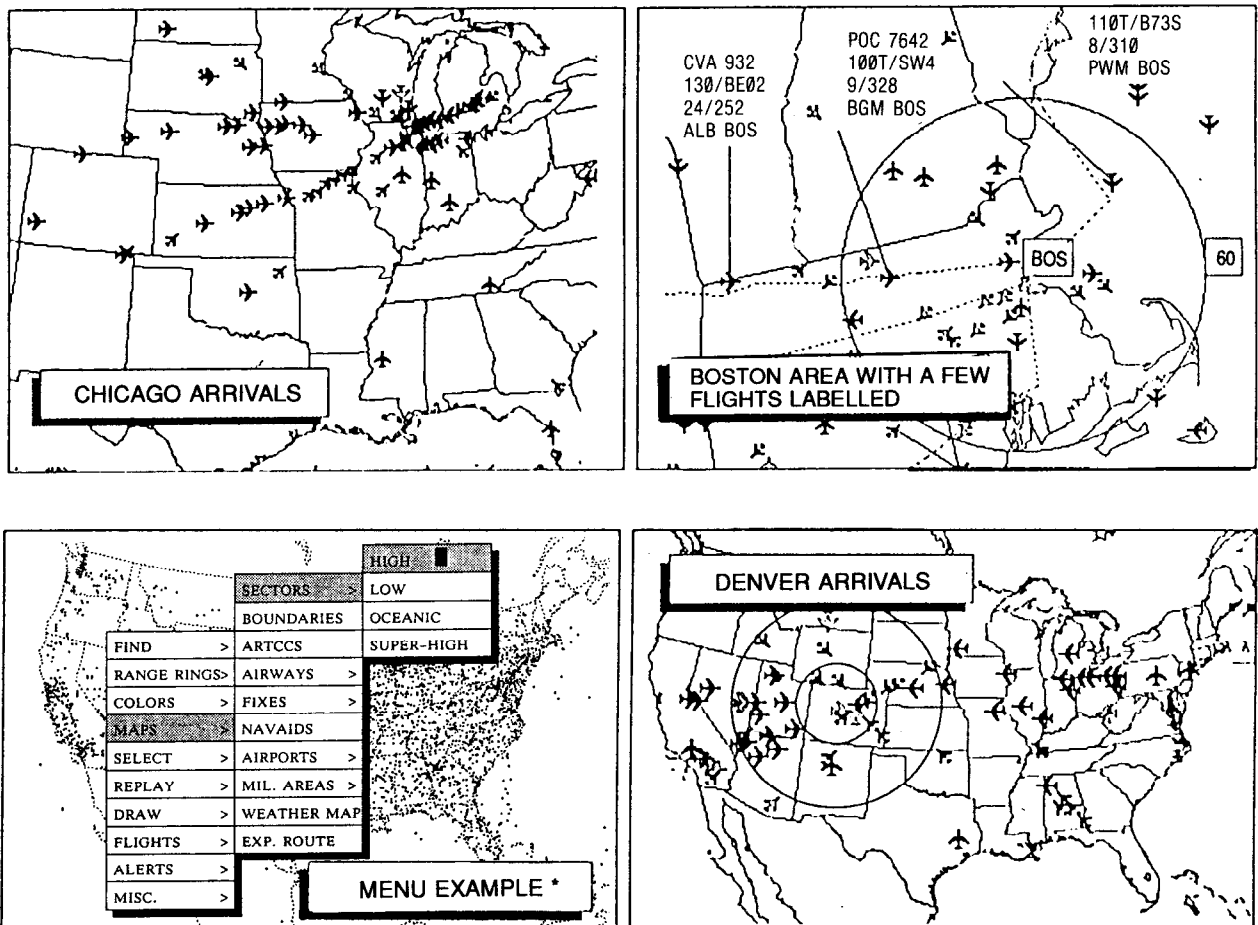

* Dots represent airborne IFR traffic

Figure 1. Examples of ASD presentations

Appendix B

Examples of Typical Messages for the Control of Air Traffic Flow

1. GENERAL

Timely advice on restrictions to the flow of air traffic is essential whenever flow control measures are contemplated. The following messages might be used in circumstances where it is necessary to impose restrictions on the flow of air traffic:

- a) flow delay advice message;
- b) flow control restriction message; and
- c) flow control cancellation message.

2. FLOW DELAY ADVICE MESSAGE

2.1 When it becomes apparent to an ATC unit that aircraft arriving at or departing from a specific location within a pre-determined period of time will experience significant delays, i.e. for a period of an hour or more, pilots and aircraft/aerodrome operators concerned should be advised of the expected delays or restrictions that will be applied. Such advice is dispatched by means of a flow delay advice message disseminated either by AFTN or voice circuits.

2.2 If possible, the initial flow delay advice message should be sent at least three hours prior to the time the delay is expected to occur. Subsequently, the traffic situation should be reviewed periodically and a revised flow delay advice message sent as soon as significant changes to the situation occur or are expected to occur.

2.3 The flow delay advice message should contain:

- a) the designation of the ATC unit imposing the delay;
- b) the location where delays are expected or where restrictions are likely to be applied;
- c) information on the traffic concerned (route, destination, etc.);
- d) the flight level(s) concerned;
- e) the off-load route available (designation, condition); and

- f) the anticipated length of delays and the nature and duration of the restrictions, if any.

3. FLOW CONTROL RESTRICTION MESSAGE

When an ATC unit finds it necessary to impose restrictions on the flow of air traffic into a given area, it should transmit a flow control restriction message to the ATC units concerned, specifying the reason in sufficient detail to provide adjacent ATC units with an appreciation of the situation. The flow control restriction message should contain:

- a) the designation of the ATC unit imposing the flow control restriction;
- b) the location where flow control restriction is being applied;
- c) information on the traffic concerned (route, destination, etc.);
- d) the flight level(s) concerned;
- e) the off-load route available (designation, conditions);
- f) the nature of the flow restriction;
- g) the expected duration of the flow restriction; and
- h) remarks.

4. FLOW CONTROL CANCELLATION MESSAGE

When a flow delay advice or flow control restriction message has been issued or a restriction has been imposed, the ATC unit which imposed the delay or restriction should transmit a flow control cancellation message when the delay or restriction can subsequently be reduced or cancelled. The flow control cancellation message should contain:

- a) reference to the previous message which is being cancelled; and
- b) a statement of what portion, if not all of the previously sent delay or restriction message, is cancelled.

Appendix C

Techniques for ATC Sector/Position Capacity Estimation

1. INTRODUCTION

1.1 Knowledge of the capacity of air traffic control sectors or ATC operating positions is necessary for two reasons. Firstly, for long-term planning, adequate warning is required of any future shortfall in capacity, as indicated by traffic forecasts. Secondly, if there is already a shortage of capacity requiring the application of flow control, it is necessary to know what the capacity is, in order to limit air traffic to a level which does not overload the system or penalize the operators excessively.

1.2 A considerable amount of work has been devoted in recent years to methods of estimating capacity. Of particular interest has been the work proposed by the United Kingdom, Directorate of Operation Research and Analysis (DORATASK Methodology for the assessment of ATC en-route sectors capacity — DORA Interim Report 8818; the application of this technique to current London Terminal Area Sectors — DORA Interim Report 8916; and calibration of the DORATASK Simulation Model on two en-route sectors at the London Air Traffic Control Centre — DORA Report, 8927) and the work by Messerschmidt, Bölkow und Blohm (MBB) of Germany resulting in the development of a procedure to quantify the control capacity of ATC working positions, known as the “MBB Method”. The essence of both methods was to measure the necessary time for all control working actions and to relate this time to the total time available.

Note.— The most appropriate measure of capacity was likely to be the sustainable hourly traffic flow, rather than daily or annual flows. Such hourly capacities could be converted into daily or annual values.

2. SUMMARY OF THE “DORATASK”* APPROACH

2.1 The proposed DORATASK work centred on the assessment of the workload carried by the radar controller, summing the time spent on routine and conflict resolution (observable) tasks on the one hand, and planning (non-observable) tasks on the other. In addition to these two interrelated elements of the controller’s tasks, there was a

third element — a “recuperation” time. This was a minimum proportion of time not allocated to specified tasks (observable or non-observable) but considered essential for the safe operation of the sector. The controller’s time, therefore, is divided between observable tasks, non-observable tasks and periods of recuperation. Although the workload was determined by the sum of the time spent in observable tasks and non-observable tasks, the capacity is considered as the level of workload which leaves the controller a safe margin for recuperation.

2.2 Observable tasks are those which can readily be recorded and timed by an outside observer; examples include radiotelephony (RTF) and telephone communication, strip marking and direct-voice-liaison co-ordination. Routine tasks, for a particular aircraft, are those which must be carried out even if there are no other aircraft in the vicinity. In order to get from “A” to “B”, all aircraft need to contact ATC to be given certain headings and flight level clearances and be handed off to the next sector. The sequence of instructions routinely given to an aircraft will be virtually fixed by the route it takes through the sector and by its origin and destination. The routine workload was, therefore, assessed by assigning aircraft to one of a set of standard flight profiles through the sector; associated with them were fixed sequences of tasks and, hence, a task execution time.

2.3 A simulation model was introduced to utilize the traffic sample to assess the number of occasions on which the controller would consider taking additional action because of the presence of another aircraft, including those not on the controller’s frequency. The total observable workload was the sum of time spent on routine tasks and on conflict resolution.

2.4 The routine workload during (say) an hour’s observation was dependent solely on the number of aircraft

* The United Kingdom DORATASK models were used to assess the capacity of airspace sectors and to determine constraints on traffic throughput in both terminal areas and en-route airspace; recently, they have been used to model the development of airspace in South-east England beyond the year 2000.

in each flight profile that enter the sector. The conflict resolution workload, however, would increase during a peak flow of traffic, as opposed to regular flow.

2.5 Non-observable tasks are those which are carried out almost continuously by the busy controller in parallel with the observable tasks, and which cannot generally be directly recorded or timed by the observer. These tasks, which include monitoring the radar screen and planning future actions, are, however, critical to the business of the sector controller. The non-observable workload was determined by calculating, for each aircraft within the sector area, how many strips it produces and how many other strips already present on the boards must be checked against it when it is first given to the radar controller. This number of checks was then multiplied by a "time per strip check" to give the total non-observable workload. The time for a strip check was not considered as a duration time for a physical task but as a factor calculated when the model was calibrated to reflect the time taken by the whole planning task. The latter was the main aspect of DORATASK which required more detailed research. This kind of workload would be increased significantly during a peak flow of traffic.

2.6 The workload measure for a given sector and traffic sample was the sum of the observable and non-observable workload times. To arrive at capacity it was necessary to determine a minimum proportion of time that the controller must have for recuperation if the sector was to continue to be operated safely. This proportion was likely to increase with the length of time that a "capacity" flow rate was expected to continue. Initially it was assumed that the sector would operate at capacity for no more than one hour without either the controller changing or the traffic declining. The amount by which the traffic flow was to be set at a lower rate in order for safe operation to continue was studied further. While it was assumed that the time spent per strip check, which determined the weight given to the planning workload, was two seconds, the following conclusions were derived:

"THE AVERAGE WORKLOAD AT CAPACITY MUST BE LESS THAN 80 PER CENT AND WORKLOADS OF 90 PER CENT MUST NOT BE EXCEEDED MORE THAN 2.5 PER CENT OF THE TIME."

2.7 The calibration of the DORATASK model was carried out in two parts. Firstly, the workload predicted by the model was compared with the observed workload during the study period and the model parameters were adjusted to align the two. Secondly, the workload was plotted against flow for a number of hours for two sectors

whose capacity was agreed upon beforehand by other means; the criterion for setting the capacity as outlined in 2.6 above was derived from the results.

2.8 The principles of the DORATASK methodology of airspace sector capacity estimation remain fundamentally the same whether they are applied to the en-route sectorization or to the terminal control area (TMA) sectors. Three notable changes are, however, required in the implementation of the method in TMA sectors. Account must be taken of the workload involved in the control of stacks. The conditions used for identifying potential conflicts must be altered to allow for the additional complexity of a specific TMA route structure. Finally, the method for modelling the planning workload must be altered to reflect the fact that the controller relies principally on the radar screen for conflict detection, rather than on the stripboard.

3. SUMMARY OF THE "MBB METHOD"

3.1 The "MBB Method" concerning the estimates of the capacity of an ATC working position was based on the quantification of the workload of a radar controller position. This was possible through:

- a) categorization of all observed working actions, i.e. the number of "working units" the controller is able to perform;
- b) time measuring of all observed categories; and
- c) consideration of the airspace capacity which depends on the conflict risk within the sector and thus on sector structure and traffic characteristics.

Since not all of the working units could be observed, the corresponding times were registered indirectly. This was carried out through extra work to register the controller's "free capacity", i.e. time which the controller does not need to perform his control task.

3.2 The following working action categories have been defined in order to evaluate them concerning time:

- a) length of RTF transmissions;
- b) acting times (strip markings, sequencing the control strips for the preplanning); and
- c) required time for information registration and processing. This includes the following categories which can be directly observed in part only:

- 1) co-ordination dialogue between executive controller and co-ordinator;
- 2) visual notification of information via displays and strips;
- 3) utilization of all information in the thought- and decision-making process; and
- 4) free capacity measured using the extra work.

The required time for the categories "information registration" and "information processing" had to be investigated indirectly. The above-mentioned need of time results from the difference between the need of time for the working categories which can be measured directly and the total time available.

3.3 Investigations during several observation periods showed that different traffic situations or kinds of traffic distribution resulted in different workloads. Therefore, a direct conversion of the need of time into the amount of aircraft which can be controlled was not possible. In this regard a further step had to be carried out, namely to evaluate each aircraft according to the workload and the corresponding need of time, which the control of these aircraft created at the working position according to type and phase of flight.

3.4 The weighting, defined as "degree of difficulty of the control task", was derived from measuring the lengths of RTF between controller and pilot. The basic value was the

length of the RTF time for a fulfilled control task for the easiest possible way of an overflight without changing any flight parameter.

3.5 However, the MBB method was not indisputable. During the work on this method there were several modifications of the evaluation criteria which, in part, led to different results. First of all, the determination of the degree of difficulty of a sector was criticized, e.g. that certain elements of the controller work, such as the conflict resolution task, were not sufficiently reflected. Therefore, the load threshold values (as a capacity indicator) applied by the air traffic flow management unit for its work are today more or less "experiential values", gained from the experience of the controllers assessing their own units. Sector size modifications led to corresponding adaptation of the values, again based on controllers' experiences, but originally the MBB method gave the basic indication.

4. CONCLUSION

It should be noted that the foregoing methods are labour-intensive and, more importantly, provide capacity estimates that apply only to the conditions of equipment, manning, traffic patterns, etc. which prevailed during the observations. They cannot readily be used to assess capacity under a future airspace organization, with different equipment or procedures, under different traffic loadings, or with different manning.

Chapter 2

Co-ordination

2.1 INTRODUCTION

2.1.1 Co-ordination is the art of communicating with another with a view of reaching an agreed solution to a common problem. Without co-ordination, planning has no meaning. This chapter describes the requirement for co-ordination in airspace and traffic management, particularly in relation to the resolution of often conflicting demands on the use of airspace, the development of both national and international procedures and agreements to be used, and the efforts that are necessary to ensure services and facilities are organized to the best advantage of all users of the airspace. It cannot be stressed too strongly that without adequate co-ordination, misunderstandings as a result of lack of knowledge of each other's intentions may occur, and safety in the air may be compromised.

2.1.2 Co-ordination of civil and military airspace requirements is essential. One effective means to achieve co-ordination is to establish a national air co-ordinating committee. In some States these committees are known variously as "standing committee for the co-ordination of aviation", "joint civil/military airspace co-ordinating committee", "joint civil/military aircraft control committee". Regardless of the title, the function of such a committee should always be to mutually resolve joint civil/military aviation problems. However, it is not usual for a State to establish a single air traffic control (ATC) organization to meet the needs of both civil and military airspace requirements to ensure the uniform development and application of ATS procedures.

2.1.3 In addition to civil/military co-ordination, and of equal significance to civil air operations, is co-ordination with neighbouring States. International flights could not operate satisfactorily without regional or bilateral airspace and traffic management agreements reached through proper co-ordination. Procedures and methods to be used by ATS should be discussed at the earliest practical stage with civil agencies, who may be required to provide essential supporting services, as well as with the users, i.e. the airline operators, and other commercial and private groups.

2.2 CO-ORDINATION WITH THE MILITARY

2.2.1 Rapid changes in the sophistication and the performance characteristics of both civil and military aircraft in the early 1950s, accompanied by the construction of major civil and military airfields, and the organization of the airspace into a network of airways, terminal areas and control zones, resulted in more or less significant restrictions on the freedom of movement by military aircraft. On the one hand, the civil operators demanded safeguard of their aircraft by the rigid application of separation standards whilst the military authorities required the fullest amount of tactical freedom and flexibility in the conduct of their flight operations.

2.2.2 One of the initial objectives of ICAO was to develop international rules for the safe, orderly and expeditious flow of air traffic. The need to co-ordinate civil and military traffic movements was quickly recognized by the 10th Session of the Assembly of ICAO in Resolution A10-29 which has subsequently been reaffirmed at the 12th, 14th and 23rd Sessions. Annex 11, 2.14 contains Standards for co-ordination between military authorities and ATS. For convenience, the Standards are repeated below:

...

"2.14.1 Air traffic services authorities shall establish and maintain close co-operation with military authorities responsible for activities which may affect flights of civil aircraft.

2.14.2 Co-ordination of activities potentially hazardous to civil aircraft shall be effected in accordance with 2.15.

2.14.3 Arrangements shall be made to permit information relevant to the safe and expeditious conduct of flights of civil aircraft to be promptly exchanged between ATS units and appropriate military units.

2.14.3.1 Air traffic services units shall, either routinely or on request, in accordance with locally agreed procedures, provide appropriate military units with pertinent flight plan and other data concerning flights of civil aircraft.

2.14.3.2 Procedures shall be established to ensure that ATS units are advised if a military unit observes that an aircraft which is, or is believed to be a civil aircraft, is approaching, or has entered, an area in which interception might become necessary. Such advice shall include any necessary corrective action which might avoid the necessity for interception.”

...

2.2.3 Considerable differences exist in regard to the role which military aviation is required to play in any particular State. The methods by which civil-military co-ordination is accomplished in respective ATS organizations is left to the determination of the individual States. However, in order to understand the problem, it is necessary to consider the civil requirements for airspace in all three dimensions and relate these requirements to the environment in which the military need to conduct their operations. The resultant sharing of the airspace must therefore be made in such a manner that military operations do not constitute a hazard to the safe conduct of civil flights. A national co-ordinating organization is often established to meet these sometimes opposing objectives.

2.2.4 For practical reasons, it is not always possible to envisage a single solution to the problem of co-ordination between civil and military authorities. However, there are three main methods adopted to help smooth the integration of civil/military traffic. They are as follows:

- a) total integration: In this case a single unified service provides ATS to all aircraft irrespective of whether they are civil or military;
- b) partial integration: In this case the service is composed of both civil and military personnel and ATS are provided jointly by both authorities in common airspace;
- c) side-by-side operation: In this case ATS are provided separately by the civil and military authorities. However, co-operation and safety is ensured through appropriate co-ordination at all levels.

2.2.5 The task of a co-ordinating committee is to develop national ATS rules and procedures for approval and implementation by the respective civil and military authorities. The manner of achieving such rules and procedures is suggested by the following guidelines:

- a) procedures should, whenever possible, conform to the civil aviation rules and regulations developed by ICAO or the State concerned;
- b) aeronautical facilities and ground services required for civil or military use should be provided jointly or on a common, integrated basis;
- c) personnel in civil and military ATS units should be required to meet equal standards in training and rating, based on applicable ICAO provisions;
- d) neither the military nor the civil authority should unilaterally establish controlled and/or reserved or restricted airspace;
- e) duplication of effort in research and development as well as in practical operations should be avoided and ground facilities, equipment and services should be shared whenever practical.

2.2.6 If civil/military co-ordination is not handled properly, major problems will arise and create difficulties. The following list of subjects requires particular attention in the resolution of common problems:

- a) common terminology and abbreviations should be developed and used by both users of the airspace in order to avoid confusion in communication and correspondence. Such terms and abbreviations should, whenever possible, be those developed and published by ICAO;
- b) common rules and procedures applicable to civil and military air traffic, based on the appropriate provisions of ICAO, should be developed for use by both civil and military aircraft. These rules should, where necessary, be supplemented by specific rules covering particular operational requirements of either user. In addition, these rules should be supplemented by common operating practices and procedures. In so far as they are of concern to both users, these rules and procedures should be published in a manner so as to facilitate cross reference between both users;
- c) plans regarding the organization and use of airspace should be developed in common by both the civil and the military authorities and take account of the following factors:
 - 1) national security requirements;
 - 2) the requirements for safety, flexibility and economy of air traffic;
 - 3) the desirability of joint use of airspace by the provision of suitable services, including radar;
 - 4) compatibility of civil and military operation in the same general area;
 - 5) the need for keeping airspace reservations and restrictions to a minimum, so that minimal interference with civil or military air operations occurs;

- 6) the need to periodically review and assess the continued requirement for airspace restrictions;
 - 7) consideration of the effects of incompatibility between civil and military navigation and communication equipment;
 - 8) the inconvenience caused to each user where conflict of interest occurs between civil and military users;
 - 9) the need for joint consultation prior to the establishment of new aerodromes, military installations, navigation aids and other facilities which, once completed, have an impact on the organization and use of the airspace.
- d) military exercises having an impact on air navigation should be co-ordinated in such a manner that early liaison is established between the exercise planners and the appropriate civil authorities. Except where prevented by security requirements, details of military exercises affecting air navigation should be published with an agreed period of advance notification;
- e) in order to encourage co-operation and understanding between civil and military users of airspace, personnel employed in the provision of any ATS should receive, to the greatest extent possible, basic training to common standards. Although it is recognized that specialized civil and military training is also necessary, the aim of all training should be to produce personnel of comparable qualifications. Additionally, operating procedures for civil and military facilities should, wherever possible, be based on the same principles and be identical when possible. ICAO provisions should be taken into full account when relevant;
- f) civil and military facilities should, wherever possible, be based on the same principles and be identical when practicable. ICAO provisions should be taken into full account when relevant;
- g) provisions should be created within and, where appropriate, between States, to make possible the rapid and efficient reporting, investigating and resolving of airspace violations and/or near-miss incidents. The associated procedures should provide means for corrective or remedial action.

2.2.7 The practical application of civil/military co-ordination is based on the philosophy that the greatest degree of safety and efficiency in the utilization of airspace is achieved when civil and military air traffic are integrated in a common system, and all aircraft within national airspace are subject to common rules of the air and ATC procedures. However, it must be recognized that there will be occasions when civil and military requirements are incompatible and special airspace arrangements are necessary. Depending on the significance of either the civil or the military requirements, practical co-ordination can range from simple arrangements to circumstances whereby

significant and sophisticated military requirements must be accommodated.

2.2.8 In some States, it is common practice for military personnel to be attached to civil ATC units where they are employed in both operational and procedural positions and are also involved in areas such as research and development and airways planning. As all ATC procedures must *per se* be fully co-ordinated with the military authorities before adoption, the involvement of military personnel in the activities, as both users and providers is essential.

2.2.9 Conversely, civilian liaison personnel should be attached to appropriate military commands. These personnel should present and interpret, as necessary:

- a) the effect and purpose of civil aviation policy, regulations and procedures as they affect military operations;
- b) assist military personnel in the preparation, co-ordination and processing of arrangements for the movement of military traffic; and
- c) assist in the resolution of problems which arise out of misunderstanding of military operations, civil procedures, systems limitations, and other matters of controversial nature in relation to operations.

2.2.10 Under some arrangements, the military authorities may delegate the responsibility for co-ordinating day-to-day activities to civil ATS personnel working in area control centres (ACCs). Such activities include, *inter alia*, briefing controllers on military activities and performing liaison duties during active military operations.

2.2.11 An example of arrangements for civil/military co-ordination of ATS in one State (United States) is provided in Appendix A.

2.3 CO-ORDINATION WITH NEIGHBOURING STATES

2.3.1 Every State has a neighbour. Communicating with one's neighbours leads to an understanding of mutual problems, and co-ordination of methods, procedures and planning will lead to efficient airspace and traffic management. Therefore co-ordination between neighbouring ATS authorities, units and personnel is an essential ingredient of sound airspace planning.

2.3.2 Co-ordination with neighbouring States can be achieved by bilateral agreement or as the result of informal

or formal regional meetings. Contracting States are grouped into ICAO regions and problems arising between States which cannot be settled between them directly should always be referred to the appropriate Regional Office rather than allowing a situation to remain unresolved.

2.3.3 Aircraft travelling to and from neighbouring States should be able to do so with the least possible changes in ATS procedures. Flight crews should be able to plan their flight from point of departure to destination knowing that as they pass from one FIR to another, or as they traverse the frontier from one State to another, their cockpit workload will not be complicated by the need to be familiar with different methods or procedures.

2.3.4 To ensure maximum co-ordination, reliable means of communication ranging from aeronautical fixed telecommunication network (AFTN) circuits to direct data circuits between ATS units of neighbouring States is necessary. Direct speech circuits between adjacent ATC units are essential; it is not acceptable to relay messages through other agencies or operators.

2.3.5 Control arrangements between ATS units of neighbouring States should be based on air navigation requirements rather than being dictated by adherence to national frontiers, as geographical boundaries may not necessarily provide the best airspace management arrangement.

2.3.6 Neighbouring States need to exchange essential air movement data and discuss and agree on planning methods to accommodate peak traffic flows. States need to co-operate when formulating contingency plans to meet unforeseen circumstances.

2.3.7 Agreements for supervisory and operating controllers to visit adjacent ATC units will provide an opportunity to discuss mutual problems at the working level and can help to resolve differences. Such visits also promote good fellowship and confidence when relying on one's neighbours for help in an emergency.

2.3.8 Matters of ATS significance between neighbouring States should be made the subject of formal letters of agreement between the States and ATS facilities involved. An example of a letter of agreement is provided in Appendix B.

2.4 CO-ORDINATION WITH CIVIL AGENCIES AND USER ORGANIZATIONS

2.4.1 ATS planners should be prepared to work closely with and, in some instances, rely solely upon the information or service provided by outside agencies. These agencies and user organizations include meteorological services, communications agencies, airport management and local government organizations. The often conflicting requirements of the civil users who include the airline operators, general commercial aviation, training establishments, private flying associations and specialized activity interests such as helicopter and agricultural spraying and crop dusting groups, gliding associations, etc., can also, at one time or another, influence the method by which an ATS airspace problem is resolved.

2.4.2 Co-ordination with civil agencies and user organizations can be arranged in a number of ways; the most usual being the setting up of working group committees comprising representatives of those agencies and groups who are likely to be affected by a particular proposal. Decisions arising from such working group committee meetings can then be distributed to the industry at large, and comments invited. Comments can be analysed and alternative proposals implemented, if appropriate. This method of co-ordination provides a logical, clear cut and relatively quick way of resolving an ATS problem. In practice, however, it is seldom the case. ATS planners must not only be skilled in negotiations but must also be prepared to justify the need for change with detailed and accurate data. In most cases, the end result will be an agreement by consensus, with planners putting forward compromise proposals to achieve an acceptable traffic management solution.

2.4.3 Occasions will arise when ATS planners have to make unilateral decisions in order to resolve an airspace problem of a particularly urgent nature and where safety is involved. In such an event, the operators and agencies concerned should be fully appraised, as soon as possible, of the reason for such action. If warranted, meetings to review and analyse the effects of such actions should be arranged.

Appendix A

Civil/Military Co-ordination of Air Traffic Services in the United States

1. As early as 1945 in the United States a policy for the development of a civil/military ATC system along common lines was determined, and resulted in the formation of the Air Co-ordinating Committee with the object of achieving an integrated and co-ordinated federal aviation policy.

2. The need for a common system was expressed in the following excerpts from the Air Co-ordinating Committee's Civil Air Policy.

“The national interest dictates that a single, integrated system of air navigation and traffic control be developed and maintained so as to permit the efficiency in the use of modern aircraft capabilities required for defence, economy and the safety of persons and property.

The single air navigation and traffic control system must:

- a) satisfy the basic requirements of all civil and military air operations (excluding special military needs peculiar to air warfare);
- b) assure safe and reliable operations under all prevalent conditions;
- c) be capable of immediate integration with the air defence system of the United States.

There is a need to provide for safety and efficiency in civil operations while simultaneously meeting military demands for mobility, flexibility, speed of operational handling and a system capable of integration within the continental air defence network.

It shall be the continuing policy of the United States to:

- a) provide for a single national common civil/military system of air navigation and air traffic control. The national integrated system shall satisfy the air navigation and air traffic control requirements of all civil and military air operations, except for those special military requirements peculiar to air warfare;
- b) provide a common system that shall be capable of immediate integration with the air defence system of the United States and will constitute an auxiliary to the air defence network;

- c) provide for an accelerated joint civil/military programme of research and development to bring and keep the system abreast of current and foreseeable future operational requirements;
- d) accelerate the transition to the most advanced concept of this common system.”

3. Although the creation of the Federal Aviation Administration (FAA) under the Federal Aviation Act of 1958 resulted in some changes in the administrative handling of airspace designation and development of ATC procedures, it did not however, pre-empt military participation. Instead it provided a more expedient means to refine and develop a more true and efficient common system. Moreover, its provisions are such that the deputy administrator's job can be filled by a military officer on active duty.

4. For the successful accommodation of military air traffic, the military requirements can be categorized into those operations which could be hazardous to non-participating aircraft and those which are not. Those that may be inherently hazardous are conducted in segregated airspace termed special use airspace, which is commonly known as restricted areas and warning areas.

5. Restricted areas are established over the sovereign territory, or more simply, the land areas of the United States. Restrictions to flight are imposed within that airspace. Warning areas differ from restricted areas in that they are established offshore in international airspace where no regulatory restriction can be imposed to flight within the airspace. However, warning areas are depicted on aeronautical charts in the same manner as restricted areas to alert non-participants to the existence of possible hazardous conditions. Instrument flight rules (IFR) clearances will be issued by ATC for flight through joint use warning areas only when hazardous operations are not taking place.

6. Joint use restricted and warning areas are established when it has been determined that the area can be released to FAA when it is not in use. In this case, a letter of agreement is executed by the FAA and the using military agency. The letter of procedure assigns an FAA facility as the controlling agency and defines the conditions under which non-participating civil and military traffic may be authorized to operate within the area.

7. Historically, offshore airspace is the ideal place to conduct hazardous air activity because of the natural separation from people and property and generally from other air activity. As a result, much of the offshore airspace around the United States has been transformed into warning areas. Corridors to accommodate access to United States terminals from the oceanic routes are provided on a full or part-time (joint use) basis.

8. The next sub-category of military operations is that which is not considered essentially hazardous to non-participating users. These operations cover a wide range of activities and are for one reason or another unique to the military requirements and need special considerations when being absorbed into the common ATC system. Most of the time, specific information concerning these unique activities is given to the other airspace users and at times, some form of procedural segregation is employed. In other cases, such as simple mass movements of military aircraft, an airspace reservation is used. This category also covers military operations areas (MOAs) established to accommodate certain military training activities such as air combat manoeuvres, practice air intercepts, aerobatics, etc.; controlled firing areas where activities are conducted under controlled conditions which eliminate hazard to non-participating aircraft and ensure the safety of persons and property on the ground; and areas wherein high volumes of pilot training or unusual types of training activity take place, but neither of which are hazardous to other aircraft.

9. Of the more than 3 600 000 plus square miles of airspace over land areas of the United States, approximately 510 000 square miles or one-seventh is designated as special use airspace. An additional 463 000 square miles of the airspace offshore are designated as warning areas. However, this does not mean that all this airspace is unavailable to other users.

10. Through co-operation of civil and military authorities, approximately 85 per cent of this airspace has been designated joint use airspace. In joint use airspace, ATC may authorize operations, thus making this airspace available to other users at times when its reservation for the designated military use is not necessary.

11. Additionally, special portions of the airspace are set aside, procedurally, to segregate military and civil oper-

ations. These include military training routes to accommodate low level, high speed operations and altitude reservations.

12. Military flight operations required to support logistic military requirements receive no special consideration even though they place a significant workload on the ATC system. Such logistic (transport) operations are handled routinely by ATC as is any other user.

13. The most difficult point of civil/military co-ordination is reaching agreements required by changing requirements. Military needs brought about by increased performance of aircraft and type of activity result in requirements for changes of the airspace structure or changes to the route structure required to cater to changes in the volume of operations, specific flow demands and access to specific terminals. Such changes can only be made by agreements resulting from negotiation and proper co-ordination.

14. Problems associated with the desired utilization of joint use airspace have stemmed mainly from the lack of sufficient immediate communication between the user agency of that airspace and the aircraft using the joint use airspace at a given time. The users establish special units to co-ordinate the schedules for the use of this airspace. The communications network linking user units, which may be dispersed over a wide geographic area, the flight scheduling unit, and the ATC unit, are complex. Therefore, the actual status of occupancy of activities within such an area cannot be determined rapidly and can result in poor airspace utilization.

15. A system has been developed by the United States Navy to optimize the utilization of such areas. The system, known as the "Fleet Area Control and Surveillance Facility (FACSFAC)", provides radar surveillance of operating areas, range scheduling for user activities, range control, and positive control of air surface and sub-surface units. The system is installed at three locations where the greatest densities of military and civil en-route and terminal air traffic are experienced. In the foreseeable future, these automated systems will be integrated with the ATC automated system. Once implemented, these developments will constitute a further step towards the creation of a real-time environment, which will provide for optimum use of joint use airspaces.

Appendix B

Sample Letter of Agreement Between States and ATS facilities

Letter of agreement between the Area Control Centre of Maiquetia, Venezuela and the San Juan CERAP

Subject: Procedures relating to the co-ordination and routing of IFR air traffic between the ACC of Maiquetia and the San Juan CERAP

1. INTRODUCTION

1.1 *Effective date:* 22 January 1981

1.2 *Objective:* To establish procedures for the co-ordination and routing of IFR air traffic between the CTA/FIR of Maiquetia and San Juan.

1.3 *Scope:* The procedures contained in this operational letter of agreement that supplement or detail, when so required, the procedures prescribed by ICAO in the pertinent documents, shall be applied to all IFR aircraft that cross the common boundary of the CTA/FIRs of Maiquetia and San Juan.

2. CONTROL PROCEDURES

2.1 *Routing of air traffic:* Except for prior co-ordination effected individually for each flight off airways, the air traffic between the CTA/FIRs of Maiquetia and San Juan shall be routed along ATS routes outlined in the respective AIPs.

2.2 Separation

2.2.1 *Vertical:* The San Juan CERAP shall assign flight levels of the second semicircle to all aircraft which enter the Maiquetia CTA/FIR on ATS route UA21/A21 and UB16/B16, and will assign flight levels of the first semicircle on ATS route UG9.

2.2.1.1 The Maiquetia ACC shall assign flight levels of the first semicircle to all aircraft which enter the San Juan CTA/FIR on ATS route UA21/A21 and UB16/B16 and flight levels of the second semicircle on ATS route UG9.

2.2.2 *Longitudinal:* During the transfer of control the minimum longitudinal separation to be used between aircraft flying at the same altitude on the same ATS route shall be fifteen (15) minutes at or above flight level 200; twenty (20) minutes separation shall be used for aircraft operating at or below flight level 190.

2.2.3 *Transfer of control points (TCP):*

ATS route UA21/A21	ARMUR (CTA/FIR boundary)
ATS route UG9	KIKER (CTA/FIR boundary)
ATS route UB16/B16	MILOK (CTA/FIR boundary)

3. CO-ORDINATION PROCEDURES

3.1 General

3.1.1 The co-ordination between the ACC of Maiquetia and the San Juan CERAP shall be effected in accordance with the Standards, Recommended Practices, and procedures prescribed by ICAO.

3.1.2 The Maiquetia/San Juan direct speech circuit shall be used as the primary means of co-ordination for all active IFR air traffic.

3.1.3 The simultaneous mode will continue to be used for the forwarding of filed flight plans (FPLs).

3.1.4 Departure and arrival messages shall not be required for flight originating and terminating at airports located within the Maiquetia and San Juan CTA/FIR boundaries.

3.1.5 All co-ordination involving active IFR air traffic shall be forwarded to the appropriate ACC at least twenty (20) minutes prior to the aircraft's estimate for the position serving as the co-ordination point for the ATS route involved.

3.1.6 *Positions serving as co-ordination points:*

ATS route	Point
UA21/A21	ARMUR (CTA/FIR boundary)
UG9	KIKER (CTA/FIR boundary)
UB16/B16	MILOK (CTA/FIR boundary)

3.1.7 In the event the above procedures cannot be carried out because of failure of the Maiquetia/San Juan direct speech circuit, co-ordination of all active IFR air traffic shall be effected as follows:

- a) via the direct speech circuits Maiquetia-Curacao, San Juan-Curacao;
- b) via the direct speech circuits Maiquetia-Piarco, Piarco-San Juan; or
- c) via San Juan Radio (ARTNC) or, if not feasible;
- d) via AFTN.

3.1.8 In the event of failure of the Curacao/Maiquetia or San Juan-Curacao direct speech circuits, the ACC of Maiquetia and the San Juan CERAP agree to act as relay for the affected ACC.

3.2 Communications

3.2.1 The transfer of the air-ground communications of an aircraft from the transferring ACC to the receiving ACC shall be made at least five minutes prior to entering the airspace of the receiving ACC.

3.2.2 The receiving ACC shall not notify the transferring ACC that it has established ground-air communications with the transferred aircraft unless specifically requested to do so.

3.2.3 San Juan ACC shall transfer aircraft communications to the Maiquetia ACC on frequency 125.2 MHz.

3.2.4 Maiquetia ACC shall transfer aircraft communications to the San Juan ACC on frequency 134.3 MHz.

4. REVISIONS

4.1 This agreement shall be subject to revision whenever a modification of Standards, recommended methods of supplementary regional procedures of ICAO occurs which might affect the procedures contained in this agreement, or when new communications facilities, or new air traffic services which might affect these procedures are commissioned. In the case of changes in ICAO regulations, the San Juan CERAP or the Maiquetia ACC shall initiate the amendment of this agreement and in the cases of new installations or modification of existing installations, the facility concerned shall initiate the modification procedure. For any other matter which might make it advisable to change this agreement, the interested facility shall propose the pertinent revision.

5. DISSEMINATION

5.1 The dissemination of the agreement and of its subsequent modification shall be made in full by a pertinent AIC fifty-six days before the effective date, and furthermore, the facilities shall include in their respective AIPs, Section RAC, those parts of interest to air operations.

5.2 This letter of agreement cancels the letter of agreement between the Maiquetia ACC and the San Juan ACC dated 3 July 1978.

Signed in Caracas, Venezuela on 25 September 1980.

Chief, NAV/ATS Standard and Procedures Department, Venezuela

In Representation of the San Juan — ACC
Chief, San Juan CERAP

In Representation of the Maiquetia — ACC
Chief, Maiquetia — ACC

Chapter 3

ATS Incident Reporting

3.1 INTRODUCTION

3.1.1 This chapter is concerned with incidents specifically related to the provision of ATS and known as air traffic incidents. The term air traffic incident is meant to mean a serious occurrence involving air traffic such as a near collision or a serious difficulty caused by faulty procedures, or the lack of compliance with applicable procedures or the failure of ground facilities resulting in a hazard to aircraft.

3.1.2 The specifications in ICAO *Annex 13 — Aircraft Accident Investigation* apply to activities following accidents and incidents, but nothing in Annex 13 is intended to impose an obligation on States to conduct an investigation into an incident. However, when the accident/incident investigation authority institutes an investigation of an incident, the procedures in ICAO Annex 13 and the ICAO *Manual of Aircraft Accident Investigation* (Doc 6920) should be followed where applicable. In such case the ATS investigation should be a part of the investigation by the accident/incident investigation authority.

3.1.3 Reporting of air traffic incidents and ATS investigating procedures should be established in order to ensure high standards of safety in the conduct and control of air traffic. For this purpose, ICAO has developed an air traffic incident report form for use by pilots and controllers when submitting or receiving a report regarding an air traffic incident. This form is reproduced in Appendix A.

3.1.4 Aircraft accidents and incidents are often reported through ATS channels. Such reports and any associated information should be recorded by the unit concerned and forwarded immediately to the appropriate accident/incident investigation authority.

3.1.5 In order to assist States in their accident/incident investigation studies, and accident prevention programmes, ICAO has developed an accident/incident reporting system, which is known as ADREP. In accordance with Annex 13, States are encouraged to submit

details of accidents to aircraft above 2 250 kg and incidents, if investigated, to aircraft above 5 700 kg so that the information can be entered into the ADREP system for storage and for automated retrieval. Details of the ADREP system are contained in the ICAO *Accident/Incident Reporting Manual (ADREP Manual)*, (Doc 9156).

3.2 REPORTING PROCEDURE

3.2.1 General

3.2.1.1 Air traffic incidents are identified and designated in reports as follows:

Type of air traffic incident	Designation of incident
Near collision	Near collision
Serious difficulty caused by faulty procedures or lack of compliance with applicable procedures	Procedural
Serious difficulty caused by failure or ground facilities	Facility

3.2.1.2 The air traffic incident report form as shown in Appendix A was developed by ICAO for use when submitting or receiving a report on an air traffic incident. The purpose of the form is to provide investigatory authorities with as complete information as possible on an air traffic incident to enable them to report back, with the least possible delay, to the pilot or operator concerned the result of the investigation and, if appropriate, the remedial action taken. The form is intended for use by:

- a) a pilot for filing a report on an air traffic incident after arrival or to confirm a report made by radio;

Note.— The form, if available on board the aircraft, may also be of use in providing a pattern for making the initial report in flight.

- b) an ATS unit for recording an air traffic incident report received by radio, telephone or teleprinter.

Note.— The form may be used as format for the text of a message to be transmitted over the AFTN network.

3.2.2 Reporting by pilots

3.2.2.1 A pilot involved in an incident should proceed as follows:

- a) during flight, use the appropriate air/ground frequency for reporting an incident of major significance, particularly if it involves other aircraft, so as to permit the facts to be ascertained immediately;
- b) as promptly as possible after landing submit a completed air traffic incident report form:
 - 1) for confirming a report of an incident made initially in accordance with a) above, or for making the initial report on such an incident if it had not been possible to report it by radio;
 - 2) for reporting an incident which did not require immediate notification at the time of occurrence.

3.2.2.2 An initial report made by radio should contain the following information:

- a) type of incident, e.g. near collision;
- b) radio call sign of aircraft making report;
- c) position, heading or route, true airspeed;
- d) flight level, altitude or height, and aircraft attitude;
- e) flying conditions (e.g. instrument meteorological conditions (IMC) or visual meteorological conditions (VMC));
- f) time of incident in Co-ordinated Universal Time (UTC);
- g) description of other aircraft, if relevant;
- h) brief details of incident, including, when appropriate, sighting distance and miss distance.

3.2.2.3 The air traffic incident report form initially reported by radio should be submitted by the pilot to the ATS reporting office of the aerodrome of first landing. The pilot should complete sections 1 and 2 supplementing the details of the radio report as necessary.

Note.— Where there is no ATS reporting office, the report may be submitted to any other ATS unit.

3.2.3 Reporting by ATS

3.2.3.1 Following an air traffic incident the ATC unit involved should proceed as follows:

- a) identify and designate the incident in accordance with the procedure detailed in 3.2.1;
- b) if the aircraft is bound for a destination located within the area of responsibility of the ATS unit in whose area the incident occurred, arrangements should be made with the operator to obtain the pilot's report on landing;
- c) if the aircraft is bound for a domestic destination, the ATS unit of destination should be requested to obtain the pilot's report on landing;
- d) if the aircraft is bound for an international destination, the ATS authority at destination aerodrome should be notified and given full details of the incident (by AFTN) and requested to obtain the pilot's report;
- e) the civil aviation authority of the State of Registry and the State of the Operator should be notified of the incident by the State of occurrence (by AFTN) together with all available details;
- f) if the incident involves another aircraft, similar action should be taken in regard to both parties;
- g) complete the air traffic incident form;
- h) ensure that the accident/incident authority and the national ATS authority are notified of all reportable incidents.

3.3 INVESTIGATION AND DOCUMENTATION

3.3.1 It is essential to determine the cause of an air traffic incident, with the minimum delay so that action can be taken to prevent a recurrence. Immediately following an air traffic incident all documents and tapes relating to the incident should be impounded. Controllers, supervisors and officers-in-charge of the ATS unit concerned should take all necessary measures to preserve relevant documents and to record as many details as possible while they are still fresh in their minds.

3.3.2 The initial ATS investigation is normally carried out by the ATS unit to which the incident has been reported or which noted it. The ATS unit should obtain the following information:

- a) statements by personnel involved;
- b) tape transcripts of relevant radio and telephone communications;
- c) copies of flight progress strips and other relevant data, including recorded radar data, if available;
- d) copies of the meteorological reports and forecasts relevant to the time of the incident;
- e) technical statements concerning the operating status of equipment, if applicable;
- f) unit findings and recommendations for corrective actions, if appropriate.

3.3.3 To give effect to the air traffic incident investigating process, an investigating team should be established. The team should include the officer-in-charge of the ATS unit or a senior ATS officer as team chief and ATS experts, other specialist officers from flight operations, flight calibration, telecommunications engineering or other fields, if required. In addition and when necessary, the controller(s) involved in the incident should be given the opportunity to nominate as a member of the team an experienced controller of equal grade to represent him during the investigation. When two units are involved, the unit in whose area the incident has taken place should initiate action to convene the incident investigation team and include an offer for officers of the other's unit to participate.

3.3.4 Should the pilot, the operator or a civil aviation authority refuse to provide information necessary for the proper investigation of an air traffic incident, the State conducting the investigation should proceed with the investigation using available information and inform the ICAO Regional Office of the difficulties encountered.

3.3.5 The proceedings of an air traffic investigating team, as well as papers and records used by it should be treated as confidential material. Specific *prima facie* facts required by the team should be prepared by the unit and should include, as appropriate:

- a) names and operating positions of involved ATS personnel;
- b) full details of the sequence of events in narrative form;
- c) names of pilots and operating companies and details of aircraft involved;
- d) reports from controllers involved as prepared before leaving the unit on the day of the occurrence;
- e) reports from pilots involved, if possible as prepared at the next point of touch-down, preferably in penscript but acceptable by AFTN signal and, if necessary, through the operator's office;
- f) the marking and impounding of relevant voice recording tapes, flight progress strips and other flight data including recorded radar data if available.

3.3.6 The report of the ATS investigating committee should include a summary of the incident and the cause. The report should contain all relevant information, in chronological sequence where appropriate, and concluding with a list of findings, conclusions, causes and safety recommendations for the purpose of accident/incident prevention. Recommended corrective actions should also be included in the report. The committee should not make recommendations on personnel or disciplinary action in the

event of controller error because the fundamental objective of the investigation is prevention of accidents, not to apportion blame or liability.

3.3.7 In addition, the following information should be submitted as appendices to the report:

- a) statements by personnel involved;
- b) tape transcripts of relevant air-ground and telephone communications;
- c) copies of meteorological reports or forecasts relevant to the incident;
- d) copies of flight progress strips and other data relevant to the incident, including recorded radar data, if available;
- e) any technical statements concerning the operating status of equipment, if applicable.

3.3.8 On completion of the investigation, full details of the findings should be sent through appropriate channels to the pilot, and/or the operator and the civil aviation authority of the State in which the aircraft is registered.

3.4 ANALYSIS OF ATS INCIDENTS

3.4.1 The analysis of an incident should be considered in relation to system operation and have regard to factors such as the following:

- a) *Procedures* — Were the procedures and separation standards applied, correct for the situation?
- b) *Data and display* — Was the displayed data correct and complete in terms of local unit instructions? Was the displayed information properly interpreted and utilized?
- c) *Co-ordination* — Were the prescribed co-ordination procedures adequate and correct and were they correctly and fully applied?
- d) *Communication* — Was correct phraseology used by all personnel involved? Was there any failure to communicate clearly and concisely which may have given rise to error or misunderstanding? Was there any failure to note and correct any incorrect read back of information? Was there any failure to obtain acknowledgement of the receipt of information?
- e) *Equipment* — Was the performance of relevant technical equipment adequate? (If any failure or malfunction of equipment caused or contributed to the incident, specialized technical advice or evidence should be sought.)

- f) *Personnel performance* — Were any factors present which may have affected an individual's performance, e.g. fatigue, illness, personal problems, etc.? (While personnel errors may be established by the committee, degrees of negligence, carelessness or blame are not to be specified.)
- g) *Task environment* — All aspects of the working environment should be considered which may have affected the performance of personnel, e.g. background noise, heating, ventilation, ambient light levels, etc.
- h) *General operations* — Were all personnel familiar with the traffic situation and pertinent data before assuming responsibility for an operating position? Were the duties and responsibilities for the operating position(s) clearly defined? The adequacy of staffing in relation to traffic density should be considered as well as relief, and adequate rest periods. If applicable, was the level of supervision satisfactory?

3.4.2 Once the analysis of an ATS incident has been completed, information on the results, including conclusions and recommendations reached, should be made available to all concerned so that corrective action, etc. may be taken and all concerned are fully aware of the final results.

3.5 RELEASE OF INFORMATION

3.5.1 In the interest of accident and incident prevention, the State conducting the investigation should publish the report as soon as possible. When the State considers that disclosure of records, described below, might have an adverse effect on the availability of information in that investigation or any future investigation, then such records shall not be made available.

3.5.1.1 Such records include:

- a) statements from persons responsible for the safe operation of the aircraft;
- b) communications between persons having responsibility for the safe operation of the aircraft;
- c) medical or private information regarding persons involved in the accident or incident;
- d) cockpit voice recordings and transcripts from such recordings;
- e) opinions expressed in the analysis of information, including flight recorder information.

3.5.2 Members of the press and general public who make inquiries into occurrences should be referred to a person authorized to release information.

— — — — —

Appendix A

Air Traffic Incident Report Form

AIR TRAFFIC INCIDENT REPORT FORM

For use when submitting and receiving a report on an air traffic incident and when preparing for transmission a message on such incidents. Shaded boxes contain items to be included in an initial report by radio.

Section 1. - GENERAL INFORMATION

Type of incident		INCIDENT: NEAR COLLISION/PROCEDURAL/FACILITY*
Name of pilot-in-command	B	
Operator	C	
Identification markings of aircraft	D	
Aircraft type	E	
Radio call sign - In communication with - Frequency at time of incident	F	
Aerodrome of departure	G	
Aerodrome of first intended landing and destination, if different	H	
Type of flight plan	I	IFR/VFR/NONE*
Position at time of incident - Heading or route - True airspeed	J	
FL, altitude or height - Altimeter setting - Attitude	K	Level flight/climbing/descending/turning*
Flight weather conditions at time of incident	L	IMC/VMC above/below cloud/fog/haze horizontally from cloud Between cloud layers In cloud/rain/snow/sleet/fog/haze Flying into/out of sun flight visibility
Date and time of incident in UTC	M	Reported by radio to ... AFIS/TWR/APP/ACC/FIC* at ... (date/time)

Section 2. - DETAILED INFORMATION

Description of other aircraft, if relevant: Type, high/low wing, number of engines Radio call sign, registration Markings, colour, lighting Other available details		
Description of incident If desired add comment or suggestion, including your opinion on the probable cause of the incident. (In case of near-collision give information on respective flight paths, estimated vertical and horizontal sighting and miss distances between aircraft and avoiding action taken by either aircraft.)	N	<i>(Continue overleaf if necessary)</i>
Date Time	O	
Place of completion of form	P	
Function and signature of person submitting report	Q	Function and signature of person receiving report

Section 3. - SUPPLEMENTARY INFORMATION by ATS unit concerned

How report received		Radio/telephone/teleprinter* at ARO/AFIS/TWR/APP/ACC/FIC*
Details of ATS action: clearance, incident observed on radar, warning given, result of local enquiry, etc.	R	<i>(Continue overleaf if necessary)</i>

*Delete as appropriate

Signature of ATS Officer
Date/time UTC

Chapter 4

ATS Evaluation

4.1 INTRODUCTION

4.1.1 Standardization of procedures and methods is essential in a service which has international obligations and uses procedures involving more than one unit. The degree of standardization achieved is directly related to the proficiency with which individuals perform their duties. This in turn determines the efficiency of the service given to the users and to the travelling public.

4.1.2 Individual proficiency and standardization of procedures and methods are attained and maintained by a system of training, certification, proficiency checks and evaluations and inspections; and most essentially, by the deliberate and conscientious participation of all ATS personnel.

4.1.3 This chapter deals with the need for constant and continuous evaluation of individual ATS units and of the over-all ATS system — a task normally undertaken by personnel specifically trained to understand all aspects of the organization and charged with the responsibility of evaluating personnel proficiency and critically assessing the over-all effectiveness of the ATS.

4.2 PURPOSE AND SCOPE OF EVALUATION

4.2.1 ATS evaluation includes examination of individual ATS units such as an area control centre (ACC), an approach control office or an aerodrome control tower or other associated ATS activity, or a complete evaluation of several units or the entire national ATS system. The evaluation of ATS units is necessary to ensure that:

- a) the provision of service is maintained at the highest standard; and

- b) all units and personnel apply policies, standards, rules, procedures and separation minima in an approved manner.

Regardless of the scope of the evaluation certain common objectives are involved.

4.2.2 ATS evaluation normally includes all or part of the following provisions:

- a) assessing the service provided to the users for standardization, quality, adequacy, efficiency and effectiveness;
- b) ensuring that operating procedures conform to national standards;
- c) assessing and making recommendations concerning operational requirements;
- d) identifying any potentially unsafe procedures or operating practices so that immediate corrective action can be taken;
- e) detecting problem areas or deficiencies and determining probable causes and recommended corrective measures;
- f) examining the effectiveness of intra-unit and inter-unit communication and co-ordination;
- g) examining personnel utilization, position workload and unit establishments to ensure compatibility.

4.2.3 At the conclusion of an ATS evaluation, findings should be fully documented and recommendations made, as appropriate, where changes are required. Matters requiring urgent rectification should be notified and corrected as soon as possible, preferably before the formal report is rendered.

4.3 CONDUCT OF EVALUATION

4.3.1 Designated personnel should conduct routine ATS evaluations on a regular basis, with a recommended frequency of not less than every two years. At those units where evaluation officers are permanently assigned, evaluation should be an on-going process particularly in

respect to personnel proficiency. An interim evaluation may be conducted at selected units and, when necessary, approximately midway between routine evaluations.

4.3.2 Before commencing an ATS evaluation, it is usual to notify the officer-in-charge of the unit. This officer should arrange for whatever assistance is needed for the proper conduct of the evaluation, including arranging contact with other interested parties such as telecommunications, aerodrome management and flight operations. It may also be necessary to arrange for consultations with the operators, other civil aviation groups or with military authorities. In the latter case it is likely that some forewarning of the nature of the discussions will be needed.

4.3.3 On completion of an ATS evaluation, a meeting should be arranged and the officer-in-charge of the unit informed of any significant findings and recommendations. The purpose of the meeting is to:

- a) review the findings;
- b) identify problem areas;
- c) examine proposed alternative solutions;
- d) designate responsibility for follow-up actions;
- e) co-ordinate remedial actions;
- f) establish tentative target dates for completed actions.

4.3.4 A special evaluation may be undertaken at any time to examine a specific aspect or function. Such special evaluations may include in-flight monitoring of clearances and procedures during the course of normal duties.

4.4 DOCUMENTATION

4.4.1 On completion of an ATS evaluation, the person(s) responsible for conducting the evaluation should:

- a) compile a written report of each unit evaluated within the system;
- b) compile a written in-flight monitoring report, as required;
- c) distribute evaluation reports to appropriate authorities.

4.4.2 ATC evaluation reports should be written in narrative form and include at least the following information for each routine observation or evaluation:

- a) a description of the deficiency or problem area detected;
- b) recommendations for correction;
- c) agency or person(s) responsible for follow-up action, if appropriate;
- d) target dates for corrective action.

4.4.3 Relevant sections of the evaluation report should be sent to non-ATS units, as appropriate, for information and action as required.

4.4.4 The ATS unit should notify the appropriate authority of action taken with respect to an identified problem, preferably within 30 days of receipt of the report, and from then on at regular intervals until all outstanding items have been resolved.

AIR TRAFFIC SERVICES PLANNING MANUAL

PART II

SECTION 2. SEPARATION

SECTION 2 SEPARATION

Contents

	<i>Page</i>		<i>Page</i>
Chapter 1. Determination of Separation Minima	II-2-1-1		
1.1 Introduction	II-2-1-1		
1.2 Horizontal separation	II-2-1-2		
1.2.1 General	II-2-1-2		
1.2.2 Establishment of minima	II-2-1-2		
1.2.3 Factors to be considered in developing minima	II-2-1-3		
1.3 Vertical separation	II-2-1-4		
1.4 Reduction of minima	II-2-1-5		
1.5 Application of minima	II-2-1-6		
1.6 Operations on parallel runways	II-2-1-6		
Appendix A. Runway separation criteria for aircraft using the same runway	II-2-1-7		
Chapter 2. The Mach Number Technique	II-2-2-1		
2.1 Introduction	II-2-2-1		
2.1.1 Description of the term	II-2-2-1		
2.2 Objectives	II-2-2-1		
2.3 Prerequisites	II-2-2-1		
2.3.1 Area of application	II-2-2-1		
2.3.2 Aircraft instrumentation	II-2-2-1		
2.3.3 Flight progress information for ATC	II-2-2-2		
2.3.4 Adherence to assigned Mach number	II-2-2-2		
2.4 General procedures	II-2-2-2		
2.5 Specific procedures	II-2-2-2		
2.5.1 Introduction	II-2-2-2		
2.5.2 Separation at entry point when the following aircraft is the faster	II-2-2-2		
2.5.3 En-route step-climbs and step-descents	II-2-2-3		
		2.5.4 Successive aircraft operating at different Mach numbers in the absence of computer-assisted conflict prediction	II-2-2-3
		Appendix A. Table — Application of Mach number technique when the following aircraft is the faster	II-2-2-4
		Chapter 3. Composite Separation	II-2-3-1
		3.1 Introduction	II-2-3-1
		3.2 Application of composite lateral/vertical separation	II-2-3-1
		3.3 Implementation	II-2-3-3
		Chapter 4. Minimum Navigation Performance Specifications	II-2-4-1
		4.1 Introduction	II-2-4-1
		4.2 The minimum navigation performance specification	II-2-4-2
		4.3 Lateral separation minimum	II-2-4-2
		4.4 Authority for establishment	II-2-4-2
		4.5 Evolution	II-2-4-3
		4.6 Prerequisites	II-2-4-4
		4.7 Derivation of criteria	II-2-4-4
		4.7.1 General	II-2-4-4
		4.7.2 Effect of risk of changes in system characteristics	II-2-4-5
		4.8 Assessment of the safety criteria and separation minima	II-2-4-6
		4.9 Application	II-2-4-8
		4.9.1 General	II-2-4-8
		4.9.2 Verification of performance	II-2-4-8
		4.9.3 Appraisal of operating procedures	II-2-4-9

	<i>Page</i>		<i>Page</i>
4.10 Monitoring	II-2-4-9	Appendix E. Provisions regarding	
4.10.1 General	II-2-4-9	follow-up action on observed and	
4.10.2 Monitoring procedures	II-2-4-10	reported deviations in the	
4.10.3 Radar monitoring process	II-2-4-10	NAT region	II-2-4-32
4.10.4 Practical aspects related to		Attachment 1 — Message format for	
performance monitoring	II-2-4-11	the initial notification of operators	
4.10.5 Without radar monitoring	II-2-4-12	and/or States of Registry and the	
4.11 Operational procedures	II-2-4-13	Central Monitoring Agency of an	
4.11.1 General	II-2-4-13	observed deviation	II-2-4-34
4.11.2 ATC clearances	II-2-4-13	Attachment 2 — Format of written	
4.11.3 ATC system loop errors	II-2-4-13	confirmation to operators of an	
4.11.4 Flight deck errors	II-2-4-13	observed deviation	II-2-4-35
4.11.5 Loss of navigation capability	II-2-4-13	Attachment 3 — Format of covering	
4.12 Certification and monitoring	II-2-4-14	letter to State of Registry	II-2-4-37
4.12.1 Certification	II-2-4-14	Attachment 4 — Format of letter to	
4.12.2 Equipment fits	II-2-4-15	State of Registry in respect of	
4.12.3 Monitoring of operators	II-2-4-15	deviations more than 25 NM but less	
4.12.4 Central monitoring agency	II-2-4-15	than 50 NM occurring in NAT Region	
Appendix A. Analytical development of a		but outside MNPS airspace	II-2-4-38
minimum navigation performance		Appendix F. Provisions regarding the	
specification	II-2-4-17	reporting by pilots of the performance	
Appendix B. Collision risk model	II-2-4-24	of INS and OMEGA equipment in the	
Appendix C. Estimation of occupancy		NAT region	II-2-4-39
values and variation of risk with		Appendix G. Compliance with	
occupancy	II-2-4-27	specifications of minimum navigational	
Appendix D. Description of the		performance as conditions for operation	
monitoring method used by a typical		in specified portions of the airspace	II-2-4-41
ATS unit in the NAT region	II-2-4-31		

Chapter 1

Determination of Separation Minima

1.1 INTRODUCTION

1.1.1 Separation is the generic term used to describe action on the part of ATC in order to keep aircraft, operating in the same general area, at such distances from each other that the risk of their colliding with each other is reduced. Because of the type of locomotion involved in aviation, such separation can be effected in two planes, horizontal and vertical, whereby separation in the horizontal plane can be achieved either longitudinally (by spacing aircraft behind each other at a specified distance, normally expressed in flying time) or laterally (by spacing aircraft side by side, but again at a specified distance from each other).

1.1.2 The required separation between aircraft is generally expressed in terms of minima, i.e. in distances which should not be infringed. Minima are further specified in firm values of distance; horizontally in nautical miles (NM) or degrees of angular displacement; vertically in metres or feet, or in values of time between the moment a preceding aircraft passes over a given point and that time when the next aircraft is allowed to pass over the same point.

1.1.2.1 Under some circumstances, in specified airspaces and subject to regional agreement, composite separation consisting of an element of horizontal separation combined with an element of vertical separation may be applied between aircraft (see Part II, Section 2, Chapter 3).

1.1.3 The application of separation to aircraft, based solely on position information received from pilots via air-ground communications, is generally referred to as procedural control. Control based on radar displayed position information and where the application of horizontal separation is effected by maintaining a specified horizontal distance between radar returns (blips) on a display representing the horizontal disposition of aircraft in space is called radar control. Vertical separation may also be applied between radar returns and this may be enhanced in areas where secondary surveillance radar (SSR) Mode C is used.

1.1.4 There is a significant difference between the separation minima used when applying procedural control methods and those used in radar control. The separation minima used under procedural control take into account that control is based on the "snap-shot" method, i.e. at specific locations and/or times, ATC can look at the traffic situation and make a "snap-shot" picture of the situation and ensure that all aircraft under control are suitably separated from each other and that pilot estimates as to their flight progress indicate that this will continue until such time as ATC is in a position to again review the traffic situation. The separation minima used in this case must therefore ensure that, even in the worst case conditions, i.e. in-between successive snap-shots, the required minima can be maintained or re-established should the minima have been infringed upon. It should be understood, however, that the use of the procedural control method does not relieve the controller from his obligation to continuously monitor the traffic situation.

1.1.5 In the case of radar control, ATC is provided with continuously updated information on the position of aircraft making it possible to use significantly smaller separation minima. However, the minima used under these conditions must also take into account the fact that, from radar alone, little information is provided on the future intentions of aircraft and the reaction time, the initiation of corrective action and its execution by aircraft concerned in case of conflict. In this respect possible delays in communication, reaction time for the pilot and the response time of aircraft depending on their speed and size have to be taken into account in determining the appropriate radar separation minima.

1.1.6 It should be noted that, at controlled aerodromes and during visual meteorological conditions, tower controllers apply separation to aircraft based on visual observance of air traffic by the controller concerned. This type of visual separation has much in common with radar control as well as incorporating certain elements of procedural control, especially for those phases of flight where continued visual observance of the traffic by the controller is no longer possible (e.g. special visual flight rules (VFR)).

1.1.7 In any case, the determination of the prescribed separation minima is a complex process which needs to take account of numerous factors, many of which are outside the scope and competence of ATC. Frequently it will be left to the individual controller to determine, based on sound judgement, what separation is adequate for a specific situation. However, once separation minima are established by the competent authority, it is incumbent upon ATC to ensure that the established minima are not infringed upon.

1.1.8 Because of the many variable factors involved in the determination of separation minima, it could be imagined that each State, and in some cases even each ATC unit, would apply its own separation minima, peculiar to its particular situation. This would, however, not only disrupt any effort to organize an orderly flow of air traffic between adjacent ATC units, but would also create considerable confusion amongst pilots exposed to such varying standards. It was for this reason that, from the early days of ICAO, it was agreed that separation minima should be established internationally and that such minima should only be changed through international agreement. The minima so established are specified in Annex 11.

1.1.9 In recent years, work on separation minima between aircraft has, to a growing extent, been based on the mathematical-statistical treatment of data collected on the performance of aircraft. This approach was used to develop models from which valid information regarding the likely safety of proposed measures could be derived. While such work has been extremely useful as a supplementary means of arriving at valid conclusions, it is, however, not a substitute for sound operational judgement. It therefore appears necessary to approach the issue of mathematical models with caution and to make sure that in each individual case, data collections and their subsequent treatment are likely to yield useful results and do not only confirm the obvious.

1.2 HORIZONTAL SEPARATION

1.2.1 General

1.2.1.1 Prior to discussing factors to be considered in the development of criteria for the determination of lateral and longitudinal separation minima, it is necessary to define certain basic ATC assumptions which have a significant bearing on the subject.

1.2.1.2 The ATC system is premised on the principle that the responsibility for navigation is vested within aircraft. The ATC system does not normally assume responsibility for the navigation of aircraft except in certain prescribed instances when the air traffic controller is in a better position to obtain information on an aircraft's position than is available aboard the aircraft. With the increased use of ground radar by ATC, there has been a noticeable trend towards a situation where controllers are required to assume some navigational responsibilities. In such cases, the navigation instructions (vectors) required to maintain the proper flight path are determined and issued by ATC personnel.

1.2.1.3 The determination of longitudinal separation minima is based on the quality of information available to ATC. The determination of lateral separation should be based primarily on the accuracy with which pilots can adhere to an assigned track. In many cases lateral separation minima are stated in terms of the width of the airspace to be protected along a given route or airway. Such minima must be made known to all ATC personnel concerned.

1.2.1.4 Decision, co-ordination and transmission times may have an influence on the application of longitudinal "time" separation minima, particularly where direct pilot-controller communications are not available. However, even though these factors, together with the lead times necessary in the issuance of control instructions to ensure maintenance of whatever minimum is in effect, enter in the determination process, they are not among the primary factors upon which the separation criteria are based. Furthermore, air traffic controllers are always working with estimated future aircraft relationships, and should not wait until minimum aircraft spacing conditions exist before taking control action.

1.2.2 Establishment of minima

1.2.2.1 *Longitudinal separation:* There are two distinct methods of providing aircraft separation in the longitudinal dimension: the use of time separation and the use of distance separation. Both techniques require that the quality of the information which the environment provides be analysed at the controller's display.

1.2.2.1.1 *Time separation:* The technique used in the employment of time separation can be described as the extension of an airspace sampling process, wherein certain points on the earth's surface are used as sampling points

(i.e. use of the snap-shot method). By estimating the time of passage of each aircraft over or near various pre-selected points, a display is generated portraying the estimated future time relationships of all aircraft. This future time relationship is, of course, always an estimated relationship. The estimates are revised as necessary, based on information available to the controller derived mainly from the past history of each aircraft concerned. An examination of the display will provide information (in relation to time at the selected sampling points) on:

- a) the use of airspace in the immediate past;
- b) the current airspace situation;
- c) the future-anticipated use of the airspace.

Anticipated or estimated time relationships between aircraft are thus established by controllers by monitoring the progress of aircraft in relation to other aircraft. Such progress is not normally monitored solely in relation to pilot estimates for specific points, as indicated in filed flight plan, or in-flight pilot estimates for the next position, but also by the general ability of aircraft to make good their estimated times.

1.2.2.1.2 In addition to those factors mentioned in 1.2.1.4 above, other factors involved in the determination of longitudinal time separation minima are:

- a) the accuracy of position determination over reporting points;
- b) the frequency of reporting;
- c) clock inaccuracies;
- d) a buffer.

1.2.2.1.3 *Distance separation:* In airspaces wherein a high quality of frequently renewed position information is available to the controller, longitudinal separation may be expressed in terms of distance rather than in specified intervals of estimated time over the same point. The controller's display serves as the means to analyse the available information. In this case the relevant factors involved are the relative accuracy of position information, the age or currency of the information displayed, the elapsed time between updating of the display, and a buffer. Obviously, where distance separation is used, the display must show distance relationships.

1.2.2.2 *Lateral separation:* The determination of horizontal separation based on lateral separation minima should be based on the accuracy normally achieved in routine operations with whatever designated system of navigation prescribed, plus a reasonable pilotage allowance, plus a buffer. This over-all accuracy can be

broken down into that achieved by ground equipment, that of airborne equipment and that of instrumentation components, as applicable.

1.2.3 Factors to be considered in developing minima

1.2.3.1 Procedural separation based on horizontal separation minima should be aimed at achieving the most expeditious flow of traffic commensurate with safety. Many factors have to be taken into account in their determination. Basic factors which must be considered are:

1.2.3.1.1 *Position factors:* These refer to the accuracy of position indication and the accuracy with which flight progress can be maintained. They therefore depend upon:

- a) Equipment error, or the accuracy of the navigation system, which include:
 - 1) ground equipment error;
 - 2) airborne equipment error;
 - 3) instrumentation or display error.

While it might be possible to develop a table showing the equipment errors inherent in each of the present methods of position determination, the aim must be to establish the ultimate accuracy of position assessment. In some cases the combined error may be more readily assessed than that of each of its component parts, for example, by a series of tests or experiments. It may also be necessary to consider the determination of position by the use of combination of two or more position lines obtained from different aids.

- b) Estimation errors which occur whenever a continuous indication of position is either not provided or not utilized, so that dead reckoning navigation is used between fixes. This may apply in either or both of the horizontal dimensions. ATC estimates, to the extent that they influence separation minima, are only relevant with regard to longitudinal separation. Lateral separation is based on the capability of aircraft to maintain the intended track and must be determined on the basis of the system of navigation in use, even if it is based solely on dead reckoning. When the navigation system provides the pilot with continuous track guidance, lateral deviations may well be negligible. Allowances must, however, be made for the ability of ATC to estimate future position and time relationships.
- c) Operational "tolerances" covering those deviations from the current flight plan which may be permitted without requiring notification to ATC or corrective action by the pilot, so as to avoid pilot interventions and/or air-ground communications which would be of

little or no benefit to both pilots or ATC. These may be quantified for both horizontal dimensions. The fact that pilots are required to notify ATC only when the estimate for the next position is found to be in error by three minutes or more recognizes that in general no useful purpose would be served by requiring pilots to report smaller deviations. However, this value may vary in particular environments and may therefore be changed to smaller or larger values by regional agreement or by the appropriate ATS authority. The fact that an aircraft which is off track is required to take action to regain its track as soon as practicable after the deviation is realized covers this aspect in the lateral dimension.

1.2.3.1.2 *Control factors:* These factors are associated with the over-all efficiency of the ATC system and comprise:

- a) Communication delays which cover the period between the moment an event (in the case of an aircraft passing over specified position or, in the case of ATC, the issue of a new clearance) takes place and the time it is notified to the person who needs to be informed of it. Such delays, expressed in time may occur:
 - 1) due to frequency congestion by pilot or controller transmissions, caused by the amount of traffic to be handled;
 - 2) in the case of pilots, by other priority duties such as completion of other cockpit duties, including calculation of the next estimate;
 - 3) in the case of controllers, by other priority duties or by the time required to recognize the need for action, to formulate, co-ordinate and communicate such action;
 - 4) due to the time required for data transfer from controller to controller by voice, or by relay, involving machines (e.g. computer, cardatype, teletype).
- b) Clock errors which may occur in the time-keeping of ATC and/or pilots and in the recording of such times. A one-minute difference in time between actual and reported positions or estimates could be accentuated when considering two aircraft in relation to each other or other aircraft. This item will apply only when longitudinal separation based on time intervals or on the Mach number technique is used.

1.2.3.1.3 Human factors, both on the part of pilots and controllers, have to be considered and generally include:

- a) the respective level of experience with the environment in which the flight is conducted;

- b) the mental attitude of the personnel concerned;
- c) their reaction time, especially in case of unforeseen events.

1.2.3.1.4 *Buffer:* The buffer is a minimum physical distance of defined dimensions to accommodate:

- a) variations in an aircraft's flight path due to air movements, etc.;
- b) the size of the aircraft;
- c) an additional "miss" distance.

1.2.3.2 In addition to the factors listed in 1.2.3.1.1 to 1.2.3.1.4, other factors to be taken into account when determining longitudinal separation minima for timed approaches are:

- a) the time which a landing aircraft is expected to occupy the runway. This time may be affected by:
 - 1) the visibility which exists at the time of landing;
 - 2) the runway lights and the configuration, distribution and lighting of runway exits;
 - 3) runway surface contaminants (e.g. snow, slush, ice, water);
- b) unfavourable meteorological conditions. If weather conditions are such that the pilot may encounter difficulties in completing the landing, the longitudinal separation may need to be increased to allow the first aircraft to land before the second aircraft commences descent on final approach;
- c) types of aircraft in the approach sequence, and speed differentials;
- d) additional separation required to account for wake vortex;
- e) effect of departures from the runway to be used for timed approaches;
- f) effect of possible deviations from the specified approach path where the timed approach is commenced from a point which is not in line with the runway;
- g) effects of a missed approach;
- h) other relevant factors.

1.3 VERTICAL SEPARATION

1.3.1 Vertical separation is provided at present by the use of the following minima:

- a) 300 m (1 000 ft) up to and including flight level (FL) 290;
- b) 600 m (2 000 ft) above FL 290.

1.3.2 Experience has shown that these values are adequate to meet safety requirements under normal conditions. It is, however, also specified that, in exceptional cases of severe turbulence and over mountainous terrain, when it is expected that aircraft may be exposed to sudden and unpredictable vertical displacements, greater values should be used.

1.3.3 However, especially on long-range over water flight, favourable meteorological conditions are generally available in only a comparatively small height band of approximately 1 200 m (4 000 ft) to 1 800 m (6 000 ft) depth. Since fuel conservation has now assumed a significant role in the economy of flight operations, studies have been undertaken to explore the possibility of reducing the vertical separation minima above FL 290, thus providing more levels in the operationally desirable height bands, especially where traffic density makes it impossible, at times, for all aircraft to use the favourable levels.

1.3.4 These studies have, however, shown that more data are required on some of the factors having a determining influence on the reduction of vertical separation, before it will be possible to firmly establish that reduction of vertical separation can be safely accomplished (see ICAO Doc 9352, Item 2).

1.4 REDUCTION OF MINIMA

1.4.1 Any proposal for a reduction of the horizontal separation minima, as permitted by the *Procedures for Air Navigation Services — Rules of the Air and Air Traffic Services (PANS-RAC)*, Part III, Section 9, should be judged with particular regard to the following points.

1.4.1.1 *The navigation accuracy:* This is a function of the navigation aid(s) used and takes into account the characteristics of both the airborne and ground components, as well as the accuracy with which navigational guidance is applied by the pilot. Together with the accuracy of height-keeping, this navigation accuracy in the horizontal plane forms a “volume of navigation uncertainty”. It can be shown that the “volume of uncertainty” decreases significantly as the navigation error decreases. Thus, an improvement of navigation accuracy is generally a prerequisite to a reduction of separation minima.

1.4.1.2 *The time interval between position reports:* An air traffic controller, in providing adequate separation between aircraft, must, in general, rely on the position

information provided by the pilot. Such position reporting will be done via air-ground communications and the reliability of such reports must be kept in mind. When radar is available and the aircraft has been identified, the controller is normally provided with position information with every scan of the antenna, thus considerably reducing the time interval between successive position determinations. However, rapid and reliable air-ground communications are required to take advantage of such position information to accomplish effective radar control of aircraft, using reduced separation.

1.4.1.3 When communications are interrupted, or the loading on individual communication channels is too high or when an aircraft with radiocommunication failure has to be considered or when the length of time between successive position reports is long, the separation minima must be higher than would otherwise be the case, i.e. a further block of airspace must be added to the basic “volume of navigation uncertainty”. However, once position reports are again received by the ATC unit in normal conditions, the additional block of airspace should no longer be needed and the normal volume required reverts to that for navigation uncertainty.

1.4.1.4 *The rate of closing:* This factor takes into account the speed with which the amount of clear airspace between any two aircraft diminishes. Its effect is directly proportional to the length of exposure time before new reports on the positions of aircraft concerned are received, i.e. to the distance between compulsory reporting points. In the case of opposite direction, crossing or joining traffic, the rate of closing is normally apparent from the estimates given by the pilots concerned in relation to the common point where they will meet. However, in the case of aircraft operating successively along the same track and level, with the slower aircraft in front, the block of airspace provided between them must be large enough to ensure that the preceding aircraft is not being overtaken by the faster successive one while flying between two relatively distant reporting points.

1.4.1.5 *The controller’s display:* The way in which traffic information is presented to the air traffic controller has a significant bearing on the establishment of control procedures and on the amount of time necessary for him to assimilate the situation in which he may be required to act to maintain separation. It can therefore be said that the more dynamic the display system, the better the chances of successfully reducing separation between aircraft, provided the display changes do not exceed the average human capability for observing and analysing the situation and arriving at a decision.

1.4.2 The possible reduction of vertical separation minima is already covered in 1.3.

1.4.3 An example of reduced separation used by one State (United States) to accelerate successive departures and arrivals on the runway in use at an aerodrome is given in Appendix A.

1.5 APPLICATION OF MINIMA

The preceding paragraphs provide guidance as to the methods by which separation minima can be determined and the requirements that have to be met to achieve this. Many possible and varying circumstances have to be foreseen and values have to be given to the various factors. With regard to those factors in 1.2.2.2 which affect the lateral displacement of aircraft in relation to their tracks, it is necessary to determine navigation tolerances and apply them to the routes to be catered for in order to ascertain those areas where lateral separation will not exist. It is equally necessary to designate positions, in relation to those areas, between which other forms of separation (longitudinal or vertical) must be applied. As no universal system has yet been developed in respect of the calculation of separation minima, extreme care should be exercised to ensure an adequate level of safety. In addition, it must also be ensured that, where particular minima, other than those prescribed by ICAO, are applied, their use does not cause traffic integration problems in adjacent areas.

1.6 OPERATIONS ON PARALLEL RUNWAYS

Note.— The procedural aspects involved in the simultaneous use of parallel runways are contained in the PANS-RAC, Part IV, Sections 5 and 13.

1.6.1 At a number of the more important airports in the world, where traffic density is very high, it has been found that one way to increase the capacity (i.e. the total number of aircraft which can be accommodated by ATC in a given period of time) was to provide for the simultaneous use of parallel (or slightly diverging and non-intersecting) runways. Such simultaneous use of runways can take different forms:

- a) both runways are used simultaneously for arriving aircraft with departing aircraft interspersed between landings as required; or
- b) both runways are used simultaneously for departing aircraft with arriving aircraft interspersed between take-offs as required; or
- c) one runway is used for arriving aircraft while the other is reserved for departing aircraft; or
- d) a combination or alteration of all of the above, as dictated by circumstances and traffic demands.

1.6.2 The use of runways at specific aerodromes not only depends on the physical layout of the aerodrome but also on the prevailing traffic situation at a given time, as well as on a large number of other, strictly local conditions which vary from location to location, i.e. aids available to ATC, layout of runway exits, taxiways, the manoeuvring area in general, the terminal layout, etc. Last but not least, the prevailing meteorological conditions (including those influencing wake turbulence) are an important factor in determining the use of runways.

1.6.3 Therefore, when considering the simultaneous use of runways, in whatever form, it must be ensured that a decision is taken only after all relevant factors have been carefully reviewed in co-operation with all parties concerned, including representatives of major users, the airport operator and those technical services on whose action the continued availability of equipment and facilities required for the safe use of the agreed procedures depends.

Appendix A

Runway Separation Criteria for Aircraft Using the Same Runway

1. GENERAL

PANS-RAC, Part V, 13 and 14 describe procedures for the control of departing and arriving aircraft. Runway separation criteria for aircraft using the same runway developed and at present in use by the United States are outlined in the paragraphs that follow (ref. FAA Manual 7110.65C, Air Traffic Control, paragraphs 1110 and 1120).

2. CATEGORIES OF AIRCRAFT

For the purpose of the separation described below, aircraft are classified in the following categories:

- a) Category I. Light-weight, single-engine, personal-type, propeller-driven aircraft. (Does not include higher performance, single-engine aircraft such as the T-28.)
- b) Category II. Light-weight, twin-engine, propeller-driven aircraft weighing 12 500 lb or less such as the Aero Commander, Twin Beechcraft, DeHavilland Dove, Twin Cessna. (Does not include such aircraft as a Lodestar, Learstar, or DC-3.)
- c) Category III. All other aircraft such as the higher performance single-engine, large twin-engine, four-engine, and turbo-jet aircraft.

3. DEPARTING SEPARATION

A departing aircraft shall be separated from a preceding departing or arriving aircraft using the same runway by ensuring that it does not begin take-off roll until the preceding landing aircraft has taxied off the runway or the other aircraft has departed and crossed the runway end or turned to avert any conflict. If distances can be determined by reference to suitable landmarks, the other aircraft need only be airborne if the following minimum distance exists between aircraft:

- a) when only Category I aircraft are involved — 3 000 ft;
- b) when a Category I aircraft is preceded by a Category II aircraft — 3 000 ft;
- c) when either the succeeding or both are Category II aircraft — 4 500 ft;
- d) when either is a Category III aircraft — 6 000 ft.

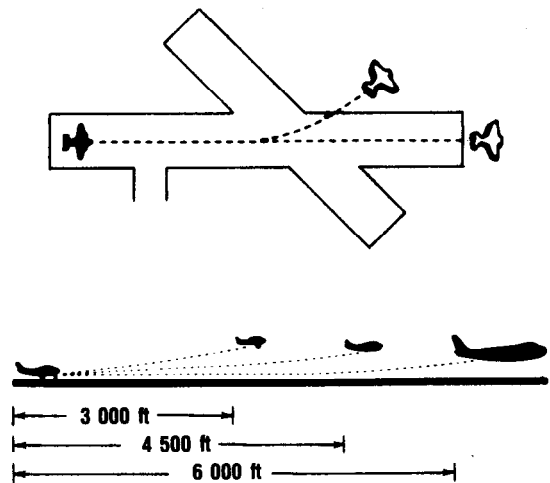

Figure 1

4. ARRIVAL SEPARATION

An arriving aircraft shall be separated from another aircraft using the same runway by ensuring that the arriving aircraft does not cross the landing threshold until one of the following conditions exists:

- a) the other aircraft has landed and taxied off the runway. Between sunrise and sunset, if distances can be determined by reference to suitable landmarks and the other aircraft has landed, it need not be clear of the runway if the following minimum distance from the landing threshold exists:

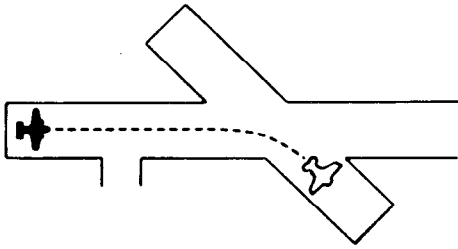

Figure 2

1) when a Category I aircraft is landing behind a Category I or II — 3 000 ft;

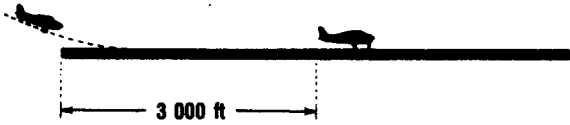

Figure 2 a)

2) when a Category II aircraft is landing behind a Category I or II — 4 500 ft;



Figure 2 b)

- b) The other aircraft has departed and crossed the runway end. If distances can be determined by reference to suitable landmarks and the other aircraft is airborne, it need not have crossed the runway end if the following minimum distance from the landing threshold exists:
- 1) Category I aircraft landing behind Category I or II — 3 000 ft;
 - 2) Category II aircraft landing behind Category I or II — 4 500 ft;
 - 3) when either is a Category III aircraft — 6 000 ft.

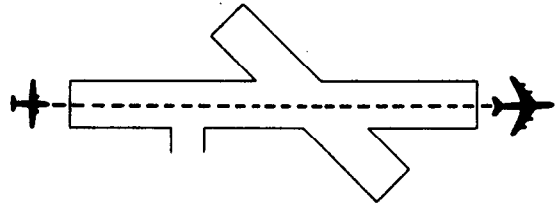

Figure 2 c)

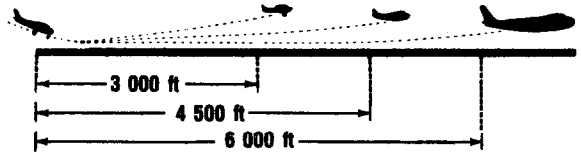

Figure 2 d)

Chapter 2

The Mach Number Technique

2.1 INTRODUCTION

2.1.1 Description of the term

The term "Mach number technique" is used to describe the technique of clearing turbo-jet aircraft operating along the same route to maintain specified Mach numbers in order to maintain adequate longitudinal separation between successive aircraft at, or climbing or descending to, the same level.

2.2 OBJECTIVES

2.2.1 The principal objectives of the use of the Mach number technique are:

- a) to ensure continued longitudinal separation between successive aircraft on long route segments with a minimum of Air Traffic Control (ATC) intervention;
- b) to obtain improved utilization of such routes, thus contributing to the economy of flight operations of traffic concerned.

2.2.2 To achieve these objectives the speeds of aircraft operating along the same track at the same level or climbing or descending to operate at the same level are stabilized. This stability permits reasonably accurate projections of the expected longitudinal separation between aircraft to points well beyond the point where separation is first confirmed, which reduces the need for frequent ATC intervention.

2.2.3 Practical experience in the North Atlantic (NAT) region has confirmed the assumptions made above. It has been found that successive aircraft operating along the same track at the same level and aircraft climbing or descending to operate at the same level as another aircraft and maintaining the same Mach number also maintain a reasonably constant time interval between each other, when checked by position reports over the same point. This

is due to the fact that the aircraft concerned are normally subject to approximately the same wind and temperature conditions. Minor variations in speed which might temporarily increase or decrease the spacing between aircraft tend to be neutralized over prolonged periods of flight.

2.3 PREREQUISITES

2.3.1 Area of application

The application of the Mach number technique is particularly suitable for areas where the environment is such that position reporting and ATC intervention with individual flights can, at times, be subject to delay. In addition, the following represent typical characteristics of the route structure and environment which make the use of a given area suitable for the application of the Mach number technique:

- a) aircraft in the area generally follow the same or diverging tracks until they are provided with other forms of separation;
- b) operations conducted in the area comprise a significantly large phase of stable flight (e.g. not less than one hour) and the aircraft concerned have normally reached an operationally suitable level when entering the area.

Note.— *The effect of seasonal jet stream phenomena should be examined closely before introduction of the Mach number technique on a regular basis.*

2.3.2 Aircraft instrumentation

The use of the Mach number technique in a given area is based on the assumption that the relevant instruments used by aircraft to which this technique is applied have been calibrated in accordance with applicable airworthiness practices. Therefore, both States of Registry and operators concerned should take the necessary measures to ensure continued compliance with this prerequisite.

2.3.3 Flight progress information for ATC

ATC units using the Mach number technique must have at their disposal the latest forecast upper wind information, or position information obtained from previous aircraft. Such information is necessary in order to permit ATC to prepare (either manually or by means of a computer) flight progress strips showing calculated estimated times over significant points up to and including the exit point from the area wherein the technique is applied in order to confirm that the required longitudinal separation will exist at the exit point.

2.3.4 Adherence to assigned Mach number

Unless otherwise advised by the pilot concerned, ATC will assume that the last assigned Mach number will be maintained both in cruise and in any cleared step-climbs or step-descents made in the course of the flight.

2.4 GENERAL PROCEDURES

2.4.1 Application of the Mach number technique should always be based on the true Mach number.

2.4.2 The ATC clearance must include the assigned Mach number which is to be maintained. It is therefore necessary that information on the desired Mach number be included in the flight plans by pilots intending to operate along routes in the area concerned.

2.4.3 ATC has a requirement to calculate estimated times at which aircraft will pass significant points along their track. These calculations are necessary both for the provision of longitudinal separation between aircraft on crossing tracks, and for co-ordination with adjacent ATC units. Therefore ATC must be provided with necessary data to do this.

2.4.4 It is very important that the estimates for the entry point to the area provided by pilots are as accurate as possible since they form the basis for the advance planning of longitudinal separation between aircraft.

2.4.5 The prescribed longitudinal separation between successive aircraft flying at the same level must be provided over the entry point and on a particular track or tracks, or exist when climb or descent to the level of another aircraft is accomplished into the area concerned.

2.4.6 Thereafter, provided that aircraft maintain their last assigned Mach numbers, intervention by ATC for the portion of flight where the Mach number technique is used, should normally only be necessary if an aircraft, for some reason, is obliged to change its number or if there is conflicting traffic on crossing tracks or a flight level change is intended.

2.4.7 The Mach number technique requires that pilots strictly adhere to the following procedures:

- a) aircraft must strictly adhere to the last assigned Mach number;
- b) if essential to make an immediate temporary change in Mach number (e.g. due to turbulence), the appropriate ATC unit should be notified as soon as possible of that change;
- c) when required by the appropriate ATC unit, the current true Mach number should be included in routine position reports.

2.4.8 Due account must be taken of problems which may be caused at entry and exit points if the longitudinal separation minima used in adjacent airspace differ from those used in the area where the Mach number technique is used.

2.5 SPECIFIC PROCEDURES

2.5.1 Introduction

The following specific procedures related to the use of the Mach number technique are based on experience gained in its use in the NAT region. They are especially useful in areas of high traffic density where position reporting and ATC intervention with individual flights may, at times, be subject to delay:

2.5.2 Separation at entry point when the following aircraft is the faster

The NAT/SPG developed a table to be used in connexion with the application of the Mach number technique at the entry point in situations where the following aircraft is maintaining a Mach number greater than the preceding aircraft. The table, reproduced in Appendix A, shows in terms of distance to be flown (in still air) the separation required in minutes at entry point.

2.5.3 En-route step-climbs and step-descents

2.5.3.1 The Mach number technique may be used as a means of applying longitudinal separation between aircraft carrying out step-climbs or step-descents and other en-route traffic on the same track provided that the prescribed minimum longitudinal separation between the climbing/descending aircraft and other affected en-route traffic exists at the time a climb/descent clearance is issued and will exist during climb/descent, as well as at each further significant point along track and at the exit point.

2.5.3.2 Application of this procedure is based on the assumption that the last assigned Mach number will be maintained during step-climbs and step-descents, and that in the event it is not feasible, ATS is advised at the time of the climb/descent request.

2.5.4 Successive aircraft operating at different Mach numbers in the absence of computer-assisted conflict prediction

2.5.4.1 If two aircraft intend to operate along the same track and at the same flight level, with the second aircraft operating at a higher Mach number than the preceding aircraft, the longitudinal spacing between the aircraft over the entry point should be increased by an additional time interval. This increase must take into account the relative ground speeds and the track distance to the common exit point to ensure that minimum longitudinal separation will exist over that point.

2.5.4.2 The calculation of ground speeds and estimated times over significant points is a time-consuming process which, in dense traffic situations, could result in unacceptable delays in issuance of clearances. A “rule of thumb” may be applied which allows clearances to be

issued in a timely manner, provided the expected minimum longitudinal separation over the exit point is subsequently confirmed when the calculated flight progress strip data become available. This rule of thumb can be stated as follows: for each 600 NM in distance between the entry and exit points of the area where the Mach number technique is used, add one minute for each 0.01 difference in Mach number for the two aircraft concerned to compensate for the fact that the second aircraft is overtaking the first aircraft.

Track distance	Required multiplier	Difference in Mach number	Required minutes to be added
1 800 NM	3	0.01	3
2 400 NM	4	0.02	8
3 000 NM	5	0.01	5

2.5.4.2.1 *Examples:*

a) An aircraft operating at Mach 0.82 is followed by another aircraft operating at Mach 0.84. The longitudinal separation minimum at the exit point is 15 min. Track distance is 1 800 NM.

Calculations:

ADD 3 min × 2 (required multiplier) = 6 min:

15 min + 6 min = 21 min longitudinal separation required at the entry point.

b) An aircraft operating at Mach 0.78 is followed by another aircraft operating at Mach 0.84. The longitudinal separation minimum at the exit point is 15 min. Track distance is 2 400 NM.

Calculations:

ADD 4 min × 6 (required multiplier) = 24 min:

15 min + 24 min = 39 min longitudinal separation required at the entry point.



Appendix A

Table — Application of MACH Number Technique when the Following Aircraft is the Faster

DIFFERENCE IN MACH	DISTANCE TO FLY AND SEPARATION (IN MINUTES) REQUIRED AT ENTRY POINT				
	001-600 NM	601-1200 NM	1201-1800 NM	1801-2400 NM	2401-3000 NM
0.01	11	12	13	14	15
0.02	12	14	16	18	20
0.03	13	16	19	22	25
0.04	14	18	22	26	30
0.05	15	20	25	30	35
0.06	16	22	28	34	40
0.07	17	24	31	38	45
0.08	18	26	34	42	50
0.09	19	28	37	46	55
0.10	20	30	40	50	60

Chapter 3

Composite Separation

3.1 INTRODUCTION

3.1.1 Composite separation is one of several methods of separation that air traffic control units may apply to ensure adequate spacing between aircraft. It consists of a combination of vertical separation and horizontal separation and uses minima for each which may be lower than, but not less than half of that used for each of the combined elements when applied individually. For example, for aircraft on adjacent tracks in oceanic airspace, the lateral separation of 120 NM may be reduced to 60 NM when combined with half the normal vertical separation of 2 000 ft, giving a composite separation of 60 NM (lateral) and 1 000 ft (vertical) separation between adjacent tracks (see Figure 1).

3.1.2 Composite separation is a means of improving airspace utilization. It has been shown that composite separation improves estimates of safety in route systems where conventional lateral separation is 90 NM or greater, due to the dispersion of some flights to other additional routes and altitudes.

3.1.3 There are two types of composite separation provided for in Annex 11: composite lateral/vertical separation and composite longitudinal/vertical separation. Guidance material contained herein addresses *only* composite lateral/vertical separation.

3.2 APPLICATION OF COMPOSITE LATERAL/VERTICAL SEPARATION

3.2.1 Composite separation is applied only in controlled airspace where traffic density warrants the introduction of a parallel track system or additional tracks. It is less restrictive than conventional lateral separation based on minimum navigation performance specification (MNPS). Use of composite separation requires that the level of safety achieved before implementation be maintained, or improved upon.

3.2.2 Composite separation may be considered where:

- a) navigation is not or cannot be accomplished by short-range navigation aids and is dependent on long-distance station-referenced aids and/or on self-contained navigation aids;
- b) separation of aircraft is dependent on non-radar control procedures; and
- c) the frequency of flights crossing the axis of the associated track system is not significant, unless satisfactory procedures can be established for handling these operations.

3.2.3 Prior to implementing composite separation, existing traffic flows should be carefully examined and operational evaluations made concerning the dispersion of traffic and the quality of navigation performance of aircraft using the system. Provision should be made for monitoring aircraft navigation performance once composite separation has been implemented in order that safety of the system can be continuously maintained.

3.2.4 The preliminary examination of a route system should include evaluation and a discussion with principle user interests of the:

- a) nature of traffic including the extent of opposite-direction traffic, occupancy of adjacent tracks and expected changes in traffic flows, including acceptability of procedures to handle track-crossing operations;
- b) navigation capability en route and in the area of the gateway fixes;
- c) communications effectiveness and reliability;
- d) the capability of the ATC systems that are involved; and
- e) collision risk relative to a pre-determined target level of safety.

3.2.5 Composite separation requires assurances that aircraft are properly established at the correct level and on the correct track on entry into the system. Radar coverage of the end points of any route structure where composite separation is applied is necessary unless there are other means of accurately determining aircraft positions. Thus

CONVENTIONAL SEPARATION

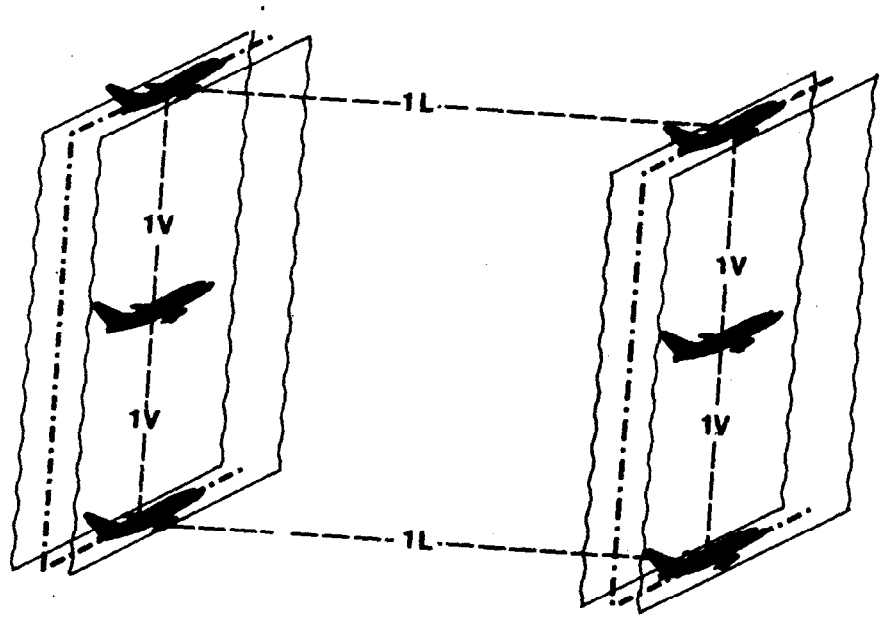

COMPOSITE LATERAL/VERTICAL SEPARATION

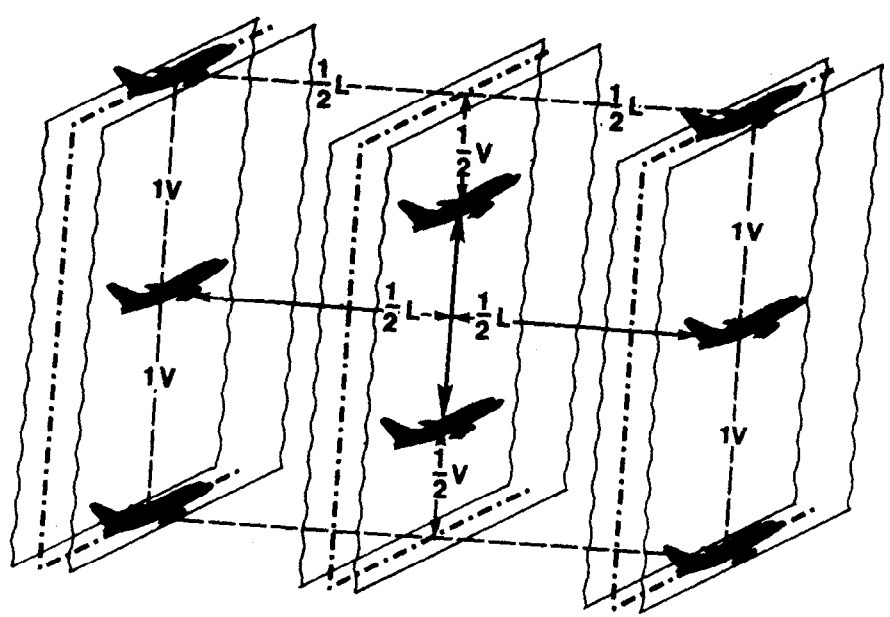

Figure 1

when considering composite separation without radar to monitor aircraft navigation performance, the following factors should be considered:

- a) adequacy of air-ground communications;
- b) location and capability of ground-based navigation aids, particularly VOR/DME to assist in correctly positioning aircraft entering the system;
- c) length of routes;
- d) meteorological conditions encountered along the routes;
- e) types of aircraft normally using the routes.

3.2.6 Proposals for introduction of composite separation are subject to regional agreement.

3.3 IMPLEMENTATION

States and operators should be given reasonable notification of the expected implementation of composite separation including the rules for normal use, as well as in-flight contingency procedures.

Chapter 4

Minimum Navigation Performance Specifications

4.1 INTRODUCTION

4.1.1 The term “minimum navigation performance” was defined by the Ninth Air Navigation Conference (1976) as the ability of an aircraft to follow its intended or assigned flight path within defined tolerances. A “minimum navigation performance specification (MNPS)” describes a level of navigation performance which must be met by aircraft operating in a defined portion of airspace, referred to as “MNPS airspace”. It is important to note that the specification does not refer to required aircraft equipment tolerances but to the navigation performance to be achieved through the use of appropriate equipment. A minimum performance specification may be expressed in vertical, longitudinal or lateral terms.

4.1.2 The objectives of an MNPS are to facilitate:

- a) the selection of a separation minimum compatible with the needs of a particular airspace in terms of traffic densities and collision risk levels; or
- b) the reduction of an existing separation minimum, on the basis of navigation performance and traffic density, while maintaining an acceptable level of safety; or
- c) the continued use of an existing separation minimum in a situation where air traffic is increasing, while maintaining an acceptable level of safety.

4.1.3 An MNPS may also be used as a method of ensuring close adherence to the cleared flight path where necessary to prevent intrusion into adjacent areas where restrictions or hazards to flight exist, i.e. prohibited, restricted or danger areas or other areas.

4.1.4 Guidance material developed by the Ninth Air Navigation Conference (1976) and relating to compliance with specifications of minimum navigational performance as conditions for operation in specified portions of airspace is shown in Appendix G.

4.1.5 The material which follows is limited to the consideration of MNPS in lateral terms and in areas where tracks are not defined with reference to point-source

navigation aids. The purpose of the material is to provide guidance for States, operators and regional air navigation bodies concerning conditions, applicable methods and procedures relevant to:

- a) the establishment of a minimum lateral navigation performance specification which must be met as a condition of operation within a defined portion of airspace (MNPS airspace);
- b) the operation and monitoring of the MNPS system of operation with respect to the attainment and continued satisfaction of the intended objectives;
- c) the choice of the lateral separation minimum to be used;
- d) the certification of operators by States of Registry for operations in MNPS airspace.

4.1.6 Before entering into the discussion of the subject, however, it should be noted that in the development of MNPS a number of new terms have come into use whose meaning should be clearly understood. These terms are:

a) *ATC system loop errors*: Lateral deviations from track by an aircraft resulting from a misunderstanding between the pilot and the controller regarding the route to be followed.

b) *Kinematic factors*: The numerical terms

$$\left(\frac{|\Delta V|}{2\lambda_x} + \frac{|\dot{Y}|}{2\lambda_y} + \frac{|\dot{Z}|}{2\lambda_z} \right) \text{ and } 2 \left(\frac{|V|}{2\lambda_x} + \frac{|\dot{Y}|}{2\lambda_x} + \frac{|\dot{Z}|}{2\lambda_z} \right)$$

used to define the parameters of aircraft size and relative motion in the risk model equation.

Note.— See equation 1 of Appendix A.

c) *Risk model*: The assumptions made, and the equations derived therefrom, in order to estimate the number of mid-air collisions in a parallel track system to which strategic ATC is applied.

Note.— See equation 1 of Appendix A.

d) *Strategic ATC*: ATC procedures are essentially strategic when the system is based on pre-planning of the air traffic flows without reliance on the use of ad hoc ATC interventions to maintain separations.

e) *Traffic occupancy*: The average number of aircraft in a parallel track system which are, in relation to the typical aircraft:

- 1) flying in the same (or opposite) direction as it;
- 2) nominally flying on tracks one (or more) lateral separation standard(s) away from it;
- 3) nominally at the same flight level as it; and
- 4) within a defined longitudinal segment centred on it.

Note.— The prefixes “single separation standard”, “multiple separation standard”, “same-direction” and “opposite-direction” are used to describe different calculations of traffic occupancy.

4.2 THE MINIMUM NAVIGATION PERFORMANCE SPECIFICATION

4.2.1 The required level of lateral navigation performance for the minimum navigation performance specification (MNPS) can be expressed in terms of the standard deviation of lateral track errors and the proportion of total flight time spent off track for specific lateral track deviations.

4.2.2 Based on development work and experience in the NAT region, the following MNPS is recommended for use in areas where tracks are not defined with reference to point-source navigation aids and where the use of such a performance specification is found necessary:

An aircraft will be deemed capable of operating in any MNPS region if, for flights of similar duration to those applicable to the NAT MNPS region, it has a performance capability such that:

- a) the standard deviation of lateral track errors is less than $6.3 \text{ NM} \times H/4.5$ (see Note);
- b) the proportion of total flight time spent by aircraft 30 NM or more from the cleared track is less than 5.3×10^{-4} ;
- c) the proportion of total flight time spent by aircraft at or between 50 and 70 NM from the cleared track is less than 13×10^{-5} .

Note.— To account for navigation aids with cumulative errors dependent on flight time (e.g. INS) the standard deviation of 6.3 NM should be adjusted when $H/4.5$ exceeds one. H is the nominal flight time in the new MNPS airspace under consideration by regional planning groups and 4.5 is the nominal hours of flight used for the NAT MNPS operations. When aids with constant errors are used (e.g. OMEGA), these must comply with the 6.3 NM standard deviation requirement regardless of route lengths.

4.2.3 The foregoing specification is intended to provide for a uniform level of minimum navigation performance in

any MNPS airspace. If applied systematically, aircraft certified for operations in any one MNPS airspace should then be acceptable in all others.

4.2.4 If it were planned to extend the application of MNPS to other parts of the world than the NAT region, and to require the same navigation performance in all MNPS airspaces, it should be noted that the NAT MNPS requirements in fact fulfil two functions:

- a) establish navigation performance criteria which must be met by all aircraft;
- b) establish safety criteria which, when met, ensure that the safety in the airspace is above the required limit.

4.2.4.1 It should further be noted, however, that if the same navigation performance criteria were to be applied in other MNPS airspaces, where different route systems, traffic densities, separation values and route lengths may exist, the navigation performance and safety criteria will no longer be the same. In fact, while the safety criteria will be of the same type, they may, however, contain different numerical values.

4.2.5 In addition to determining whether the total system of operation is meeting the required safety criteria, the monitoring authority will need to consider whether any operator or type of navigation equipment appears to fail to meet the acceptability criteria stated in 4.2.2. In such cases the attention of the State of Registry concerned should be drawn to the available data so that it can take appropriate action.

4.3 LATERAL SEPARATION MINIMUM

The minimum lateral separation which may be applied on the basis of the MNPS in 4.2.2 above is approximately 60 NM. However, a greater separation minimum may be necessary in certain portions of airspace to account for variations in route lengths and track occupancies and for limitations in the ability to verify, or to assume with a higher degree of confidence, the achieved navigation performance. This question is discussed more fully in 4.7 and 4.8.

4.4 AUTHORITY FOR ESTABLISHMENT

4.4.1 Conditions related to the establishment of MNPS which will be applied in defined portions of airspace are set forth in Annex 6, Parts I and II, Chapter 7 as follows:

“For flights in defined portions of airspace where, based on Regional Air Navigation Agreement, MNPS are prescribed, an aeroplane shall be provided with navigation equipment which:

- a) continuously provides indications to the flight crew of adherence to or departure from track to the required degree of accuracy at any point along that track; and
- b) has been authorized by the State of the operator for MNPS operations concerned.

Note.— The prescribed minimum navigation performance specifications and the procedures governing their application in MNPS-defined airspace are published in Doc 7030 in the form of Regional Supplementary Procedures.”

4.4.2 Equally important to the concept is the need to ensure that the Standards in Annex 6 (Parts I and II), Chapter 7 are also satisfied by airspace users, particularly with respect to an effective communications capability (Part I, 7.1.1 refers) and navigational systems back-up (Part I, 7.2.3 refers).

4.4.3 Authority for the specific application of MNPS in a particular airspace requires regional air navigation agreement and the inclusion of related specifications in ICAO Doc 7030 (*Regional Supplementary Procedures*). A regional body dealing with proposals for MNPS implementation will therefore need to review the content of this document to ensure that other related procedures are fully compatible with the MNPS requirement, and to initiate any proposals for amendment of the supplementary procedures which may be necessary.

4.5 EVOLUTION

4.5.1 MNPS represent a stage in a process designed to take advantage of an improved navigational capability. The need for improvements to an ATC system becomes apparent from the manner in which the system operates, i.e. the allocation of uneconomic flight levels on an unacceptable number of occasions, the need to delay departures to obtain required flight levels, etc. Early recognition of developing difficulties is facilitated by close relations between users and providers of the system. In view of the costs involved in the implementation of MNPS to at least some users, regional bodies should also consider other

means of improving system operations before concluding that MNPS is desirable.

4.5.2 Such other means, although not in any order of preference since the order may vary from region to region, include:

- a) the use of a dual parallel track system. A dual parallel track system may already rationalize a previous random track situation to an extent which is sufficient to optimize cost-effectiveness in a relatively low traffic density system. Where the traffic occupancies and/or the meteorological conditions do not require close track separations, the minima provided in Doc 7030 for use in non-MNPS airspace may then continue to be applied;
- b) the addition of further tracks as traffic density increases and dual parallel tracks become insufficient to accommodate all traffic demands within reasonable constraints. The extra route mileage involved in such additional tracks may, however, be unacceptable in terms of costs to operators;
- c) the use of consecutive flight levels on specific tracks, when traffic flows are tidal;
- d) the use of reduced longitudinal separation between aircraft on the same track based on the same TAS/Mach number;
- e) the use of composite separation between adjacent tracks (see Part II, Section 2, Chapter 3);
- f) track system structuring so as to provide different lateral separation between same- and opposite-direction traffic.

4.5.3 The application of some or all of these means can improve the ATC system to the extent that the application of MNPS is not required. The evolutionary process can also have the effect of increasing the knowledge of the particular problems involved in the operation of the ATC system and subsequently assist in the preparation and initial application of MNPS.

4.5.4 To keep interference with the free movement of air traffic to a minimum, it is essential that the application of the more stringent minimum navigation performance requirements be limited to those track structures in which compliance is desirable in order to maintain safe and cost-effective operations. Proposals for the adoption, use and enforcement of criteria in a particular portion of airspace should therefore take into account the effects of such new regulatory requirements on all operators concerned, in order to ensure that any portion of the traffic which may be excluded from use of the desirable MNPS tracks will be kept to a reasonable minimum and that satisfactory alternative tracks are available for traffic so excluded.

4.6 PREREQUISITES

4.6.1 As shown in 4.5, the application of MNPS should not be considered until other means of promoting safety and cost-effective operation have been exhausted.

4.6.2 MNPS should only be introduced in areas in which:

- a) there is a need for a parallel track structure or to locate a specific single track close to an airspace restriction;
- b) the ATC system is essentially operating in a strategic mode;
- c) lateral navigation errors of aircraft can be measured or estimated;
- d) traffic occupancy values are known or can be closely estimated;
- e) co-operation between affected ATC units is of a high order;
- f) air-ground communications coverage of high integrity and reliability is provided within the MNPS airspace and in the transition areas, especially where there is a "variable" (i.e. weather-dependent) organized track structure.

4.6.3 Regional bodies considering the introduction of MNPS will need full information from ATC provider States and airspace users in respect of:

- a) traffic details: aircraft movements and times; types of aircraft used; origin and destination of flights; requested routes and levels; ATC cleared routes and levels; airspeeds or Mach numbers used; traffic occupancies, departure delays, etc.;
- b) ATC system details: procedures applied by the area control centres involved; inter-area communications; clearance delivery criteria; radar stations involved; separation criteria in use; airspace constraint, etc.;
- c) aircraft specifications: navigation equipment and procedures in use by aircraft in the system;
- d) meteorological conditions and services available;
- e) communications considerations.

4.6.4 In addition, regional bodies should consider the extent to which the ATS infrastructure, including ACC co-ordination, is capable of fully supporting a system using reduced lateral separation based on MNPS.

4.6.5 It is essential to make personnel concerned fully aware of the principles involved in MNPS, otherwise it may well be that the full benefits of MNPS cannot be achieved. Lack of such awareness could also cause the lateral collision risk to be higher than anticipated. Regional bodies should therefore develop an information publication

specifically for the area, explaining to all concerned (both users and providers), the operation of the ATC in the proposed MNPS airspace. The MNPS operations manual for the North Atlantic may serve as a reference document in this respect.

4.7 DERIVATION OF CRITERIA

4.7.1 General

4.7.1.1 The lateral MNPS criteria developed for world-wide use are derived from the criteria originally implemented in the NAT region. The mathematical foundation for the derivation of the MNPS relies on the use of a mathematical model for estimating the number of mid-air collisions due to loss of lateral separation in a parallel track system with strategic ATC. The derivation of the NAT MNPS criteria is shown in Appendix A.

4.7.1.2 The NAT MNPS criteria were designed to ensure that, if the total system lateral navigation performance met the criteria and if the assumptions of the mathematical model remained valid, the number of mid-air collisions due to loss of lateral separation would be less than a specified target level of safety. Implicit in the derivation are assumptions about track spacing, future traffic flows, and the nature of the distribution of lateral errors. These criteria of total system lateral navigation performance were then used as a statement of acceptable aircraft lateral navigation performance, i.e. the safety requirement on the total system performance, and the requirement used to determine whether an aircraft would be allowed to operate within the MNPS region, were made the same.

4.7.1.3 In order to ensure that aircraft certified as acceptable in any one MNPS are allowed to operate in all similar MNPS airspaces, the aircraft performance criteria used to determine aircraft acceptability, given in 4.2.2, are the same for all airspaces. However, the criteria used to determine whether a proposed MNPS airspace has acceptable safety will vary from region to region depending on traffic flows, traffic characteristics, track geometry and the desired track separation.

4.7.1.4 The distinction between the MNPS aircraft performance criteria used as a measure of aircraft acceptability and the safety criteria as a measure of required total system navigation performance is fundamental to the proposed MNPS concept. It is especially important to understand this distinction when considering separations other than 60 NM, or if the

achieved navigation performance is likely to deteriorate due to flight times which are significantly longer than those experienced in the NAT region.

4.7.1.5 The following paragraphs briefly describe the effect on risk of changes to the main parameters of the NAT risk model, and how to derive safety criteria appropriate to a proposed MNPS airspace. It must be stressed, however, that the numerical results presented are only guidelines and in some particular airspaces a more thorough analysis may be required.

4.7.2 Effect on risk of changes in system characteristics

4.7.2.1 Use of risk model during MNPS planning

4.7.2.1.1 The risk model, from which the MNPS criteria were derived, is a mathematical expression which estimates the risk of collision due to loss of separation. The model includes assumptions which made it possible to write the model equation in terms of variables which can be measured relatively easily. The main assumptions used are described in Appendix B.

4.7.2.1.2 In the planning of an MNPS airspace, a comparison with known systems performance elsewhere may indicate that the target level of safety is likely to be met by a large margin. In such cases a detailed assessment of the risk by use of the model may not be necessary. If, however, the margin is comparatively small it may be necessary to examine whether the assumptions of the model and of all the numerical values of the variables, used when the MNPS criteria were derived, are still applicable in respect of the airspace concerned.

4.7.2.2 Achieved lateral navigation performance

4.7.2.2.1 The NAT MNPS criteria specify three limits on the distribution of lateral errors, namely on its standard deviation, the proportion of time spent between 50 and 70 NM off track, and the time spent more than 30 NM off track. The MNPS derivation envisages that the distribution would comprise a central core of limited lateral width that contained most of the aircraft flying hours, together with a small number of flying hours at large deviations from track. The proportion of time at these large deviations should decrease with increasing size of deviation (see Appendix A). Under these assumptions the collision risk is proportional to the time spent near the adjacent track for small changes in that time, i.e. in the 50 NM to 70 NM band for a 60 NM track separation. If the proportion of time spent in this band is halved, so will be the collision risk.

4.7.2.2.2 Assuming the other two criteria are met for a given separation standard and track length, the constraint on the standard deviation will have little effect on the collision risk, and is intended to indicate to equipment manufacturers a value likely to be compatible with the other constraints.

4.7.2.3 Track separation

4.7.2.3.1 The separation between adjacent tracks does not occur explicitly within the risk equation, but does occur implicitly in the lateral overlap term. Under the assumption that the frequency of large deviations decreases as the magnitude of the deviation increases, the collision risk in any given system will decrease as the separation between tracks increases. The rate of decrease is not specified in the MNPS criteria, and will therefore depend on the distribution of the frequency of deviations actually achieved in the region concerned.

4.7.2.3.2 The adjustment of the lateral separation is the primary means of ensuring the safety of a given system with a given achieved navigation performance, occupancy and track length. As such it provides a means to absorb, without reduction of the safety levels, any change of navigation performance due to, for instance, very long flight times when compared with times recorded in the NAT MNPS airspace.

4.7.2.4 Kinematic factors

4.7.2.4.1 The kinematic factors used in the derivation of the NAT MNPS criteria are those applicable to a “slow” drift from track in a route structure with a 60 NM track separation. If the proposed track separation is significantly larger than 60 NM, or if the majority of errors cause significantly larger relative velocities between aircraft, it may be appropriate to reconsider the applicability of the assumed values to the airspace concerned. It should be noted that the relative velocities that should be used are the average of the absolute values of the relative velocities between aircraft about to collide, rather than the average for the whole system.

4.7.2.4.2 The effect on collision risk of changes in the relative velocities will depend on the values of the occupancies of the system, and which of these velocities (lateral, longitudinal or vertical) changes. The risk model equation in Appendix C, provides a means to judge this.

4.7.2.5 Traffic occupancy

4.7.2.5.1 The risk model contains the sum of two terms which reflect the risk from same- and opposite-direction

traffic. The amount of traffic is represented by the "occupancy values" of the system (see Appendix C). The MNPS criteria were derived using a particular pair of occupancy values which were estimated to be applicable to the NAT region in 1984. Providing the other assumptions inherent in the MNPS derivation are valid and other parameters remain at the values given in Appendix A, then the ratio of the collision risk for occupancy values other than those assumed for the NAT region will be

$$\text{Ratio} = 1.42 E_y(\text{same}) + 22.42 E_y(\text{opp})$$

where $E_y(\text{same})$ = same-direction occupancy
 $E_y(\text{opp})$ = opposite-direction occupancy

When using the values for $E_y(\text{same})$ and $E_y(\text{opp})$ estimated for the NAT MNPS, the above ratio is one. It therefore follows that the total risk in a given system depends very much on the track structure, the traffic flows, and how the traffic is assigned to the different tracks, since these factors will determine the balance between the same- and opposite-direction occupancies.

4.7.2.5.2 Where the introduction of MNPS is intended to justify a reduction in lateral separation, and hence a revision to an existing structure, it may be difficult to predict the occupancy values. Often at the planning stage particular tracks and flight levels will be designated to serve a particular direction of traffic, and then operational judgement will be used to assign expected future traffic flows to paths appropriate to their direction of flight. This pattern will then be used to estimate the expected occupancies and hence the lateral collision risk. However, once the MNPS airspace and the revised tracks are implemented, the requested routes and levels, and those assigned by ATC, may be different and the resulting actual associated risk may be different from that assumed at the planning stage. It will therefore be necessary to monitor the system by analysing flight progress strips, to verify that actual traffic is conforming to the assumptions made in planning.

4.7.2.6 *Route length*

4.7.2.6.1 The route length within the MNPS airspace does not enter explicitly into the mathematical risk model and the MNPS derivation. However, it does occur implicitly in the distribution of lateral navigation errors, since it can be assumed that some types of error will increase in direct proportion to flight time since the last navigational update. In this context it is not only the flight time within the MNPS airspace that is the important factor, but also any flight time without update before entering that airspace.

4.7.2.6.2 For airspaces with similar occupancy values to those assumed in the NAT MNPS airspace any degradation of achieved performance might require an increase in separation to more than 60 NM. For airspaces with lower occupancy values this may not be necessary.

4.7.2.6.3 It was noted earlier that the criteria limiting the standard deviation of the lateral error distribution have a minor effect on risk, providing the other two criteria are met. A small infringement of the standard deviation criterion would not in itself be of undue concern, but it may provide an early warning of possible infringement of the other two criteria or of the violation of the assumptions about lateral error inherent in the MNPS derivation.

4.7.2.6.4 Analysis of the observed lateral errors of aircraft flying in the NAT region has shown that typical inertial navigation system (INS) navigational equipment will remain within the 6.3 NM standard deviation for nominal flying times typical of the NAT MNPS airspace. For route lengths in excess of those flown in the NAT MNPS airspace, account should be taken of a possible change in the standard deviation in establishing the lateral separation minimum.

4.7.2.7 *Multiple track errors*

4.7.2.7.1 The use of the risk model assumes that all the lateral collision risk occurs between aircraft nominally flying at the same level on tracks separated by a distance equal to the lateral separation standard. No allowance is made for collisions between aircraft nominally on tracks separated by two or more times the separation standard.

4.7.2.7.2 If a significant number of lateral errors occur at, or about, these higher multiples of the separation standard in a multiple-track system, the regional body considering MNPS for a specific area will need to make appropriate changes in the system model used for that area. The method used in the NAT region is described in 4.9.4.5.2.

4.8 ASSESSMENT OF THE SAFETY CRITERIA AND SEPARATION MINIMA

4.8.1 The purpose of the MNPS safety criteria is to establish limits for the navigation performance that must be achieved in the airspace concerned in order to ensure that the required safety is achieved. As stated in previous paragraphs these safety criteria will vary from region to

region. The first step in establishing such safety criteria for regions (other than the NAT region) is to compare the required lateral overlap probability with that used in the NAT MNPS. This comparison may then be used to modify the NAT safety criteria accordingly so that they satisfy the respective area or region requirements. The ratio between the two quantities is:

$$R = \frac{683}{\left[\begin{array}{cc} \text{Kinematic factor} & \times \text{Occupancy} \\ \text{(same direction)} & \text{(same direction)} \end{array} + \begin{array}{cc} \text{Kinematic factor} & \times \text{Occupancy} \\ \text{(opposite direction)} & \text{(opposite direction)} \end{array} \right]}$$

where the kinematic factors and occupancies are those applicable to the airspace being considered and the other parameters remain at values identical to those used in the NAT region.

4.8.2 The derivation of the third NAT MNPS criterion does not explicitly require the use of 60 NM separation. Rather it determines the allowable proportion of flying hours spent near adjacent tracks. The third criterion is therefore directly applicable to all separations of 60 NM or more, providing it is interpreted as applying to deviations of magnitude approximately equal to the intended track separation. The allowed proportion of time must be factored by the ratio found above to ensure the same level of safety.

4.8.3 In the NAT MNPS, the criteria, limiting deviations from track in excess of 30 NM, were defined by examination of a family of double-double exponential distributions which were assumed to be representative of the distribution which exactly met the required target level of safety. As such, the exact value of the criteria for other regions can only be found by repeating the same procedure. It is suggested, however, that an acceptable approximate value might be obtained by interpreting the criteria as applying to deviations which are greater than half the proposed separation, and by factoring the allowable time by the ratio found in 4.8.1.

4.8.4 As mentioned previously, the standard deviation criterion has little direct influence on the collision risk, provided the other criteria are met. Strictly speaking, the standard deviation may be allowed to increase linearly with the proposed separation standard, but may be further modified to allow for changes in the proportion of time at greater than half, and at the full separation. It is, however, proposed to ignore this latter correction.

4.8.5 The safety criteria for use in other than the NAT MNPS airspace are therefore:

a) the standard deviation of lateral track deviations shall be less than $(6.3 \times \text{proposed track separation} \div 60)$ NM;

- b) the proportion of the total flight time spent by aircraft at, or more than, half the track separation away from the cleared track shall be less than $5.3 \times 10^{-4} \times R$ (where R is defined in 4.8.1);
- c) the proportion of the total flight time spent by aircraft at, or less than 10 NM from any track other than the cleared track shall be less than $13 \times 10^{-5} \times R$ (where R is defined in 4.8.1).

4.8.6 In assessing the separation values which are acceptable in relation to the achieved navigation performance, the following steps should be taken:

- a) assess whether the parameters in the model equation, as shown in Appendix A, are reasonable for the planned MNPS airspace. Parameters used in the model equation include:
- 1) the average length of an aircraft (λ_x) which, for the NAT region is assumed to be 0.033 NM or 200 ft;
 - 2) the average wing span of an aircraft (λ_y) which, for the NAT region is assumed to be 0.033 NM or 200 ft;
 - 3) the average height of an aircraft (λ_z) which, for the NAT region is assumed to be 0.0085 NM or 50 ft;
 - 4) the average ground speed of an aircraft ($|\overline{V}|$) which, for the NAT region is assumed to be 480 kt;
 - 5) the average relative along-track speed of two aircraft flying at the same level in the same direction ($|\Delta V|$) which, for the NAT region is assumed to be 13 kt;
 - 6) the average relative cross-track speed between aircraft which have lost 60 NM of separation ($|\overline{y}|$) which, for the NAT region is assumed to be 47 kt;
 - 7) the average relative vertical speed of aircraft flying at the same level ($|\overline{z}|$) which, for the NAT region is assumed to be 1 kt;

If the mix of aircraft to be used in the airspace concerned is roughly similar to that used for the NAT MNPS airspace, this is true;

- b) assess the value of same-direction occupancy ($E_y(\text{same})$) and of opposite-direction occupancy ($E_y(\text{opp})$) using the methods described in Appendix C;
- c) calculate the value of the quantity R defined in 4.8.1 above, which gives the expected ratio between the probability of lateral overlap in the new MNPS airspace to that in the NAT region;
- d) determine the value of the allowable probability density of the lateral deviations at the separation S:

$$\xi = 13 \times 10^{-4} \times R$$

and of the allowable cumulative probability η at the half-separation $\frac{1}{2}S$:

$$\eta = 5.3 \times 10^{-4} \times R$$

- e) assess the distribution of lateral deviations that can be expected for the airspace concerned. If possible, this should be based on actual measurements throughout the prospective MNPS airspace of aircraft which will meet the MNPS criteria in other MNPS airspaces. If these cannot be obtained or cannot be obtained in sufficient quantity, the distribution should be developed from what data are obtainable from the prospective MNPS airspace, combined with data from other MNPS airspaces; however, utmost care must be taken in this process. Account must also be taken of the flight duration of the flights passing through the MNPS airspace, the quality of navigational guidance derived from station-referenced aids such as OMEGA, whether means of monitoring will be available to detect offenders who do not correctly apply the procedures, and any other factors which may affect the navigation performance. It should be remembered that the expected level of the standard deviation of lateral track keeping should be less than the level of the standard deviation required to meet a target level of safety allowing for the occurrence of gross errors;
- f) establish for which value of S this distribution satisfies the requirements given in d) above. The actual separation value to be used in the area concerned should then be determined in operationally meaningful terms and should be slightly higher than the value S as previously established, but never less than 60 NM.

4.9 APPLICATION

4.9.1 General

If regional meetings, after having considered all the air traffic management options which appear viable, have decided to apply MNPS, it should be applied to all aircraft permitted to operate within a specific portion of controlled airspace, which may contain one or more ATS routes. The volume of airspace should be defined both horizontally and vertically. It should be noted that the MNPS derivation only applies to parallel routes, although any proven improvement in the accuracy of navigation with respect to lateral track keeping could be exploited in different situations.

4.9.2 Verification of performance

4.9.2.1 The continued safe application of MNPS in a given portion of airspace is only feasible if there is

reasonable assurance that the criteria are likely to be met. Such assurance can be obtained by monitoring the performance of air traffic, for which two main sources are available:

- a) previously demonstrated performance elsewhere under comparable conditions and preparations for MNPS implementation in the airspace concerned;
- b) continuing performance monitoring after the MNPS have been implemented.

The first source above provides assurance that compliance with the MNPS is feasible, since it will have been met in other airspaces, and since States of Registry will have confirmed that aircraft are capable of complying with the MNPS criteria in the airspace where it is to be applied. In addition, ATC authorities will have met certain prerequisites which are required to assure operational readiness and will have made preliminary assessments of occupancy values in the MNPS airspace.

4.9.2.2 The purpose of the monitoring programme mentioned above is to ensure that, after implementation, the lateral navigation performance is in compliance with the MNPS safety requirements, and that the traffic occupancy values remain within the limits which were used when planning the system. When the introduction of an MNPS is intended to justify a decrease in lateral separation, it is desirable to verify that the required performance and occupancies are likely to be achieved before separation reductions are introduced. A sharp upward trend in occupancy should be carefully examined to determine its impact on future safety. Routine procedures should be adopted to monitor occupancy annually in each MNPS airspace.

4.9.2.3 The capability to monitor occupancies will have to be assured as a pre-requisite for the introduction of MNPS in any airspace. The form of monitoring of navigation performance depends upon the availability of resources within that area. In order to obtain assurance that the MNPS requirements are being met, the most effective form of performance monitoring is that which makes use of independent surveillance to obtain lateral deviation measurements of aircraft throughout the entire MNPS airspace. No such monitoring capability is currently available to ATC authorities in any of the areas in which MNPS is already, or is likely to be, implemented. Furthermore, there are no near-term prospects for such a capability in any portions of world-wide airspace.

4.9.2.4 In certain of these airspaces it is possible, by means of radar, to obtain lateral deviation measurements of aircraft navigating in MNPS airspace. However, these

measurements are generally limited to areas typically confined to the ends of oceanic routes. Such measurements are then considered to be representative of the distribution of lateral errors throughout the MNPS airspace by making the assumption that the distribution at the measuring points is no better (i.e. less risk bearing) than the average for the whole airspace. In interpreting the results of such monitoring, particular care is needed if it is believed that certain types of error occur more frequently in particular portions of the MNPS airspace, or if the magnitude of particular types of error varies throughout the airspace. This form of radar observation of navigational performance is at present the most advanced method of monitoring.

4.9.2.5 Lack of radar monitoring capability should not necessarily impede implementation of an MNPS requirement in an airspace, if there is a high degree of confidence that the specification of required navigation performance is likely to achieve the desired goal of system safety. This will involve consideration of the achieved navigation performance in other MNPS airspaces, the degree to which the MNPS safety requirement for this particular airspace is less stringent than the MNPS specifications which are to be met by aircraft and the likelihood that achieved performance elsewhere will be carried over to the airspace concerned. This last consideration is necessary because navigation performance may be dependent on the track system geography and location. Time-dependent, self-contained aids (e.g. INS) in which the errors accumulate with the time they are in use may have been operating a long time before reaching the MNPS airspace and this may affect accuracy if updating is not available, while station-referenced navigational systems (e.g. OMEGA) with a constant error clearly depend on signal strength and possible interference, which will vary from region to region. Besides such technical factors, the achieved performance will depend on system maintenance and operation. Different users will apply different practices, and, thus, different routes may show different system performances — if only because of the fact that the users are different. Navigation performance can thus be estimated, based upon performance on other routes, but the estimates will necessarily be uncertain. This uncertainty may not be critical if the traffic occupancy is such that the expected safety level of the system in question is well in excess of the target level, but for higher occupancies it may become quite important to have locally measured assurance of compliance with the MNPS and/or to use a larger separation value.

4.9.2.6 The implementation of an MNPS when radar monitoring is, or is not, available, is discussed more fully in 4.9.4 and 4.9.5.

4.9.3 Appraisal of operating procedures

4.9.3.1 Regardless of the method adopted for verification of system performance, there are additional measures which should be taken when MNPS is applied. They are:

- a) ATC contingency plans within the MNPS airspace should be re-appraised in the light of MNPS operations, and should be expanded to include action in the case of partial or full navigation equipment failures;
- b) ATC personnel should be trained in the meaning, application and implications of MNPS. In particular the need for the highest standards of professionalism in the issue of clearances, standardization of clearances, checking of clearance read backs, re-clearances, reporting and investigation of incidents reflecting upon safety (e.g. occurrence of clearance misunderstandings) should be emphasized.

4.9.3.2 Regions considering the application of MNPS should take into account the experience gained in other MNPS airspaces. For example, in the NAT region, in order to reduce the number of ATC clearance misunderstandings and waypoint errors, the standard position report content has been expanded so as to include information on the intended reporting point after the “next position and time over”.

4.9.3.3 After an MNPS has been introduced in a region, it is essential that a sufficient period be allowed before changes are made to the ATC system. This period will permit States:

- a) to ensure that operators, not certificated for MNPS operation, will refrain from operating in the new MNPS airspace;
- b) to allow all concerned, both users and providers, to familiarize themselves with the operational procedures in use;
- c) in a system where a radar monitoring capability exists, to permit navigation performance to be verified.

4.10 MONITORING

4.10.1 General

4.10.1.1 It should be noted that while this section deals specifically with radar monitoring of lateral navigation errors, any other system of monitoring that is independent of the aircraft navigational system and of at least

monitoring authority. The data should be regularly analysed by ATC provider States in order to determine whether the tolerances upon which the MNPS system is based are being met. Such analysis should be made:

- a) on all available data, in order to determine the over-all safety;
- b) on the data concerning specific navigation systems or specific operators, if it is suspected that they may no longer meet the specification;
- c) of the causes of deviations greater than the half separation standard, in order to determine any recurring cause for which remedial action could be taken.

4.10.3.5 The radar monitoring method used in the NAT region from the time a deviation is noticed by an ATC unit to the summary recording of all observed deviations is described in Appendix D. Provisions regarding follow-up actions used in the NAT region on observed and reported deviations are described in Appendix E.

4.10.3.6 In the event of a significant deterioration in navigation performance, whether this is due to random excursions by individual operators or the result of an obviously low level of performance by a particular type of equipment or a particular operator, corrective action will be required. In such cases, the authorities providing ATC in an environment where MNPS apply, must accept the responsibility for advising user States and operators of the action being taken to correct the situation. In the absence of agreement with the concerned State(s) of Registry to exclude the offenders from the system, it may be necessary to apply a temporary increase in separation whilst taking appropriate action to resolve the problem. It should be borne in mind that there are at least two general types of error which can result in large lateral deviations; one of these is a progressive deviation from track because of navigational inaccuracy, and the other covers the case where the aircraft flies towards or along a track adjacent to its intended track, either because of a misunderstanding between the pilot and ATC as to the track to be followed or because of faulty insertion of a specific known waypoint. These two latter types of error, though potentially hazardous, may not, in some circumstances, be prevented by an increase in lateral separation. Every effort must therefore be made to eliminate them by improvements to the operating procedures and ergonomics are an essential element in this respect.

4.10.3.7 If there is an indication that the tolerances are exceeded by a large amount, rapid response to the causes of the problem may be necessary. In such a case, the State(s) responsible for ATC in the MNPS airspace should take prompt action, after consultation with at least the

States of Registry of major affected users. An example where prompt action may be necessary could be a serious disturbance of the coverage of station-referenced systems, for instance due to unserviceability of ground stations or to very severe ionospheric disturbances. Even when the number of large deviations in the limited area in which the navigation performance is monitored is not excessive, such action must be possible if there is reason to believe that large errors might occur elsewhere.

4.10.3.8 When the tolerances are not exceeded by a very large amount, or when the observed performance merely shows a trend toward degradation, it will be more useful to have a detailed investigation made. This may take several months, but it must be kept in mind that the target level of safety is equivalent to an expectation of very long time intervals between collisions and that a small increase in the statistical probability of collision during a six (or even a twelve) month period can be therefore acceptable. Such an investigation may show that the causes for the large deviations can be eliminated by improved procedures. Such procedures should then be brought to the attention of the operators and/or air traffic controllers through the appropriate channels. Results should then be closely observed. If the causes cannot be eliminated quickly, States of Registry of the aircraft concerned should temporarily exclude offending aircraft types or operators from operation in the MNPS airspace. In view of the likely high costs to other users, an increase in lateral separation or an adjustment to the system to reduce occupancy in order to restore the situation should be made only in extreme cases and only when every other action has failed to produce the desired results.

4.10.4 Practical aspects related to performance monitoring

4.10.4.1 The data collected by radar observations for the monitoring procedure usually relate to aircraft operating at or near the exit from MNPS airspace. The assumption will be that these data are representative of the deviations throughout the MNPS airspace, i.e. that the relative amount of time spent outside each value of the lateral deviation will be the same as the proportion of measured observations outside that lateral deviation observed near the boundaries of the MNPS airspace. It is relevant to look at the consequences of this assumption more closely:

- a) For INS-equipped aircraft, it is known that the normal navigation errors tend to accumulate with the time elapsed since the last alignment or updating of the INS equipment (i.e. the error is cumulative). As far as ATC system loop errors or waypoint insertion errors are

concerned, there may be no reason to suppose that the occurrence of this type of error near the boundaries will not be representative of the whole MNPS airspace. Taking these two aspects into account, the collision risk calculated on the basis of these data will probably be higher than it would be if data for the whole MNPS airspace were available. This over-estimation may be appreciable if adjacent tracks are used by opposite-direction traffic, but will be small for tracks used for same-direction traffic.

- b) For aircraft using station-referenced navigation aids with sufficient coverage throughout the MNPS airspace, it seems likely that the lateral deviations will be independent of the time flown (i.e. the error is constant). For these cases the above-mentioned assumption seems correct.
- c) For aircraft using station-referenced navigation aids with insufficient coverage outside the area where the measurements are made, a calculation of the collision risk based only on measurements in that area would provide too low a value of the collision risk. Special care may have to be taken with temporary effects on this coverage, such as those caused by station outages.

For some regions different assumptions may be developed to reflect the nature of the errors observed in their airspace.

4.10.4.2 Errors measured by radar in the vicinity of multiples of the track separation used are not taken into account in the NAT MNPS requirements. They do, however, contribute to the risk. As a preliminary measure and awaiting further analysis, those errors which are within ± 10 NM of a multiple of 60 NM are included in the category of 50 — 70 NM errors, as well as being counted in the errors of 30 NM or more. Similar consideration should be given to the occurrence of such large deviation when considering other track systems with more than two approximately parallel tracks.

4.10.5 Without radar monitoring

4.10.5.1 Users of an MNPS airspace require a high degree of confidence that a risk-controlled track system meets the critical risk threshold. To achieve this confidence, either the navigation performance must be radar-monitored or, using the procedures outlined below, the collision risk derived from estimated parameters must be sufficiently low, so that, even if the estimated parameters were substantially in error, the system would still meet the critical risk threshold.

4.10.5.2 In order to adopt an MNPS without radar monitoring, regional bodies should take account of the

performance being achieved by similar operations in other MNPS airspace(s), of any special procedures, considerations, etc., applying in such other airspace(s), the likelihood of such performance being achieved in the airspace in question and the degree of uncertainty which should be allowed for in the unmonitored environment.

4.10.5.3 Any assessment of navigation performance in an unmonitored environment should take account of both the “core” accuracy (as represented by the MNPS standard deviation criterion) and the “gross error” rate (as represented by the half separation and the full separation ± 10 NM MNPS criteria). Unless the airspace in question, or the navigation aids available therein, have some special characteristics which differ from other MNPS airspace(s), it is reasonable to assume that aircraft certificated for MNPS operation will be capable of satisfying the standard deviation criterion. For gross errors, however, it would not be prudent to assume that certification for operation in other MNPS airspace(s) would automatically result in the gross error criteria being achieved.

4.10.5.4 There are many factors which contribute to the gross error rates, such as:

- a) the track structure arrangement (which may tend to produce waypoint insertion errors equivalent to one-track separation);
- b) the ATC system loop errors;
- c) any deficiencies in air-ground communications;
- d) the presence of aircraft not certified for operations in MNPS airspace.

4.10.5.5 In order to reduce uncertainty about gross error rate assumptions, use should be made of all available information on navigation performance. In particular, the following procedures should be implemented, if possible:

- a) verify MNPS certification of every flight;
- b) record reported navigational equipment failures;
- c) maintain and monitor statistics relating to, for example, near-collisions and navigation anomalies including ATC system loop errors;
- d) require flight crews to report position by reference to navigation equipment display and to include the position after the “next position and time over” in the position report. All means available should be used to verify position reports;
- e) any radar, or direction-finding facility, even when their coverage does not exceed that of short-range navigation aids, should be used to identify large deviations.

In order to permit these procedures to become effective, a reduction in lateral separation based on MNPS should not

be introduced until at least one year after the introduction of the MNPS.

4.10.5.6 In the absence of radar monitoring, the assumed gross error rate has a significant effect on the estimated lateral collision risk. In order, therefore, to have high confidence of meeting the target level of safety, regional bodies should carefully consider the probable rate of such errors in the airspace in question.

4.10.5.7 Regional bodies will also need to consider traffic occupancies in the airspace in question before deciding on the appropriate lateral separation minimum. The significance of variations in traffic occupancy and in gross navigational error rate is discussed in 4.7.

4.11 OPERATIONAL PROCEDURES

4.11.1 General

In order not to jeopardize safety, the system must be operated at a very high standard at all times. The achievement of the required high standard is facilitated by the use of two basic approaches:

- 1) “simplification” — with the intent that personnel at all levels and in all disciplines are not unnecessarily burdened by complexity;
- 2) “standardization” — with the intent that common procedures are learned and adopted throughout the system.

4.11.2 ATC clearances

4.11.2.1 The achievement of an acceptable level of safety requires a high track keeping performance. An aircraft which deviates from its cleared track due to misinterpretation of an ATC clearance may constitute more of a collision risk than an aircraft which deviates due to navigation problems.

4.11.2.2 In order to ensure that only MNPS approved aircraft enter designated MNPS airspace, the aircraft’s navigation capability should be indicated in the flight plan. In the NAT region such aircraft are required to include an “x” in Item 10 of the ICAO flight plan.

4.11.2.3 Pilots should, prior to entry into MNPS airspace, obtain, record and read back their MNPS airspace clearance. Particular attention should be paid to the

detection of differences between the operational flight plan, the filed (ATS) flight plan and the ATC clearance.

4.11.2.4 If a pilot receives a clearance, or re-clearance, for a flight through MNPS airspace which differs from his filed flight plan, it is his responsibility to:

- a) obtain any necessary route changes which may be required in non-MNPS airspace;
- b) re-programme his navigational equipment as far as possible, and to cross-check such re-programming;
- c) check his estimate for entry into MNPS airspace and, where necessary, notify ATC of any significant change;
- d) ensure that the revised route through MNPS airspace and associated routings outside MNPS airspace are fully understood; if any doubt exists, details should be confirmed with ATC.

4.11.3 ATC system loop errors

ATC system loop errors can be caused by incorrect interpretation of an ATC track message, misunderstandings during co-ordination between ATC units, and misinterpretation by pilots of an oceanic clearance or re-clearance. In order to afford ATC an earlier opportunity to detect such loop errors, position reporting procedures should require inclusion of both the “next position and time over” and the next subsequent position. Rapid ATC intervention cannot always be guaranteed especially as it may depend on HF communications.

4.11.4 Flight deck errors

Experience has shown that standardized procedures with regard to “navigation computer loading” are of paramount importance to minimize track-keeping errors. Many of the INS/OMEGA tracking errors which occur result either from failure to check waypoints to be inserted in the equipment against the ATC-assigned track or lack of care in loading and cross-checking of onboard control display units. For more complete advice on this subject and other related matters it is essential that reference be made to the current edition of the ICAO guidance material concerning air navigation in the NAT region.

4.11.5 Loss of navigation capability

4.11.5.1 Aircraft planning to fly through MNPS airspace (other than via specially designated routes) have to meet two navigation requirements:

- a) one refers to the navigation performance which should be achieved;
- b) the other refers to the need to carry standby equipment with comparable performance characteristics.

4.11.5.2 Some aircraft carry triple equipment, i.e. three INS, and if one of them fails even before take-off, the two basic requirements mentioned above may still be satisfied and the flight can proceed normally. For aircraft with only two operational INS systems the following guidance is offered in respect of the two general cases of failure.

4.11.5.2.1 If one INS system fails before the MNPS airspace boundary is reached the pilot should:

- a) land at a suitable aerodrome before reaching the boundary of the MNPS airspace or return to the aerodrome of departure;
- b) divert to a special route which can be recommended for use by aircraft suffering partial loss of navigation capability, i.e. comply with what is specified in the contingency plan for each respective area, subject to the following conditions:
 - 1) sufficient navigation capability remains to meet the MNPS, and the requirements in Annex 6, Parts I and II, Chapter 7 can be met by relying on short-range navigation aids;
 - 2) a revised flight plan is filed with the appropriate ATC unit;
 - 3) an appropriate ATC clearance is obtained;
- c) if sufficient navigation capability remains, obtain a re-clearance for flight outside MNPS airspace.

4.11.5.2.2 If one INS system fails after the aircraft has entered MNPS airspace, the pilot should normally continue to operate the aircraft in accordance with the oceanic clearance already received. He should, however:

- a) assess the prevailing circumstances (e.g. performance of the second system, remaining portion of the flight in MNPS airspace, etc.);
- b) decide on the most suitable action to be taken in the prevailing circumstances (e.g. whether to request clearance for flight above or below MNPS airspace or for turnback, to obtain clearance to a special route, etc.);
- c) co-ordinate with ATC as to the most suitable course of action to be taken;
- d) obtain appropriate clearance prior to any deviation from the cleared flight path through MNPS airspace.

4.11.5.2.3 If the pilot continues his flight in accordance with the original clearance (especially if the distance ahead within MNPS airspace is considerable), he should:

- a) take special care in the operation of the remaining INS, taking account of the fact that his routine method of error checking is no longer available;
- b) check the available navigation information against the main and standby compass systems;
- c) check the performance record of the remaining equipment and, if doubt arises regarding the performance and/or reliability:
 - 1) attempt visual sighting of other aircraft or their condensation trails which may provide indication of the track to be followed;
 - 2) call the appropriate ACC to obtain information on aircraft adjacent to his estimated position and/or call on VHF to establish contact with such aircraft (preferably same-track/level), obtaining from them information which could be useful (drift, magnetic heading, wind details).

4.11.5.3 Should the remaining INS fail after entering MNPS airspace, or should it give an indication of degradation of performance, or should neither INS system fail completely but the indications provided by them diverge widely and the defective equipment cannot be identified, the pilot should:

- a) notify ATC;
- b) make best use of the procedures specified in 4.10.6.3 above;
- c) keep a special look-out for possible conflicting aircraft and make maximum use of external lights;
- d) if no instructions are received from ATC within a reasonable period, consider climbing or descending 500 ft and, if taking such action:
 - 1) broadcast the action taken on 121.5 MHz;
 - 2) advise ATC as soon as possible.

4.12 CERTIFICATION AND MONITORING

4.12.1 Certification

4.12.1.1 It is fundamental to the concept of world-wide application of MNPS that approval for MNPS operation in one MNPS airspace on the basis of a world-wide navigation capability should ideally carry with it approval for operation in all other MNPS airspaces. Thus, operators certificated for NAT MNPS operations without restrictions are by definition certificated for operation in other MNPS airspaces and vice versa. From this it follows that all MNPS approvals without restrictions should be to the same standard. Guidance on compliance with specifications of minimum navigational performance for operation in specified portions of airspace is provided in Appendix F to this chapter.

4.12.1.2 Where a specific MNPS approval is sought on the basis of navigation equipment which cannot be expected to achieve the navigation standards in other MNPS airspace(s), due, for example, to restricted navigation aid coverage, the State of Registry should limit its approval to the specific MNPS airspace or to specific parts of that airspace.

4.12.2 Equipment fits

4.12.2.1 While the MNPS can be met by a wide variety of navigation systems, States may be assisted by having access to specifications of aircraft equipment likely to meet the MNPS criteria on a world-wide basis. Specific navigation fits likely to meet the MNPS are described hereafter, but it is emphasized that the equipment fit only partially contributes to the achievement of the required total quality of performance required.

4.12.2.2 Experience gained in the NAT region shows that both the INS and the OMEGA navigational system (ONS) are meeting the levels of accuracy and reliability required for compliance with the NAT MNPS. Thus dual INS, dual OMEGA, or single INS plus single OMEGA are equipment installations which, in conjunction with appropriate operational procedures, should enable the MNPS criteria to be met. It should be noted that, in order to enhance the OMEGA signal redundancy, many operators have taken advantage of the very low frequency (VLF) add-on option provided by many manufacturers of OMEGA equipment. For certification purposes the availability of VLF must not be considered in the approval for MNPS airspace operation. OMEGA coverage checks will be required in areas other than the NAT region.

4.12.2.3 Other combinations of aids have been found to be acceptable by States of Registry, such as single OMEGA with dual Doppler. In each case the particular installation combination has been carefully assessed by the competent authority before approval.

4.12.2.4 It is essential that the primary navigation system should provide continuous track guidance in terms of on-track deviation, and it is desirable that auto-pilot coupling be available to enable the aircraft to be operated automatically with minimum cross-track errors.

4.12.3 Monitoring of operators

States of Registry which have approved MNPS operations should continue to monitor operators so approved. Some States require operators to maintain, for each

aircraft, a log in which pilots record the performance of the navigation equipment, to serve as a basis for investigations, should it be found that significant equipment deficiencies occur. Appendix G contains an example of pilot reporting procedures for the performance of INS and OMEGA equipment in the NAT region.

4.12.4 Central monitoring agency

4.12.4.1 With regard to the monitoring of navigation performance in the NAT MNPS airspace, it was noted that, after the application of 60 NM lateral separation in the MNPS airspace, these activities assumed particular importance, at least during the initial stages of the use of this separation minimum. This applied, however, not only to the monitoring itself but also to the assessment of data obtained from monitoring in order to permit provider States, either individually or collectively, to determine whether a general or partial degradation of navigation performance was taking place and what corrective action was required. In this connexion, it was reiterated that the appreciation of a degradation in navigation performance, its sources and their elimination is a very complex process and that it was, for this reason, not possible to prescribe, *a priori*, standard solutions for their resolution but that this would rather have to be decided in the light of circumstances. However, there was general agreement that, under normal circumstances (i.e. those excluding partial or widespread failure of specific components of the air navigation system) the sequence of action should be:

- a) specific corrective action with regard to identified offenders; and
- b) an increase in separation if a) is not producing the required results within a specific period.

4.12.4.2 As to the monitoring activities themselves, it was noted that at present, apart from the occasion of NAT SPG meetings, there existed no occasion which permitted all provider States in the NAT region to be continuously aware of development in the navigation situation throughout the region except through half-yearly summaries published by the European Office of ICAO, which were, however, received too late to be of more than informative value.

4.12.4.3 In view of this situation it was proposed that a central agency be designated for the collection and collation of information on the navigation situation throughout the NAT region both in MNPS airspace and elsewhere. The proposals made for the operation of such a central data collecting and distributing agency were:

- a) the agency designated by the United Kingdom should receive information from Canada, France, Iceland, Ireland, Portugal, the United Kingdom and the United States;
- b) the information provided should consist of:
 - 1) monthly routine reports on the number of MNPS flight operations (OTS and Random) observed by radar during the month;
 - 2) reports on gross errors in navigation or ATC system loop errors observed by radar supplemented by information on causes, response by operators and/or States to reported errors and corrective action taken as and when these come to hand; and
 - 3) information similar to that in 2) above on errors not observed by radar but having become known through other means or from other sources.
- c) the agency will, in turn, provide all participating States on a routine basis, i.e. on a monthly basis, with a summary of the total information provided by individual participating States so that these will be kept current of over-all developments;
- d) in the case of need, the agency will provide participating States with special reports on developments should this be required in order to permit provider States to decide on a common course of action;
- e) revisions to the above arrangement, especially as regards to the frequency of the submission of routine reports by participating States and the distribution of summaries by the agency, should be made the subject of the consultation of all parties concerned taking due account of relevant developments in the region.

4.12.4.4 With regard to the errors mentioned in b) 3) above (those not observed by radar), the group felt that their inclusion and investigation could provide useful information on likely corrective action required. This applied particularly with respect to errors and/or omissions resulting from non-compliance with the prescribed position reporting procedures and errors due to misunderstandings with regard to clearances and/or differences in

interpretation between pilots and ATC regarding instructions received.

4.12.4.5 In addition to arrangements made outside the context of the monitoring agency whereby NAT gross navigation errors are notified directly to some States of Registry, the monitoring agency will circulate monthly reports to NAT SPG participants with the following contents:

- a) a table of NAT MNPS gross navigational errors eligible for inclusion in the risk analysis which have occurred since the previous scrutiny exercise;
- b) a table of NAT MNPS gross navigational errors eligible for scrutiny but not included in the risk analysis which have occurred since the previous scrutiny exercise;
- c) a table of NAT gross navigational errors which occurred in non-MNPS airspace and which have been reported since the previous scrutiny exercise;
- d) traffic figures relating to the navigational errors in a) above;
- e) copies of all documentation relevant to NAT navigational incidents;
- f) a graphical representation of the results of the immediately previous 12 months in respect of gross navigational errors of greater than 30 NM and of 50 to 70 NM, related to the MNPS criteria;
- g) such other information (e.g. results of specific data collections) as is relevant to the monitoring process; and
- h) reports relating to significant erosion of longitudinal separation.

4.12.4.6 In making these arrangements the group wanted to have it understood that the European Office of ICAO should continue to produce and distribute its half-yearly summaries on observed navigation errors in the NAT region because it felt that these summaries constituted a worthwhile reminder, especially to NAT user States, to keep developments in this region under review.

Appendix A

Analytical Development of a Minimum Navigation Performance Specification

Note.— The following material is extracted from the Report of the Limited North Atlantic Regional Air Navigation Meeting (1976), ICAO Doc 9182, (pages 1.2-13 to 1.2-24 refer).

1. INTRODUCTION

1.1 The purpose of this material is to delineate the rationale and mathematical foundation for the minimum navigation performance specification applicable in the North Atlantic region proposed in this paper. Presented herein are a statement of the assumptions involved and a derivation of the numerical values used in the specification. The minimum navigation performance specification is established to provide a mechanism to assure that the risk of aircraft collision due to loss of lateral separation will be maintained at a satisfactory level, as defined by the target level of safety (TLS). The navigation performance specification achieves this objective by:

- a) providing guidelines for new system design and procurement;
- b) establishing criteria for acceptable navigation performance as measured through a lateral deviation monitoring programme; and
- c) providing a basis for taking remedial actions in the event that the navigation performance of some aircraft is found, through monitoring, not to meet the specification.

1.2 The performance specification is designed to assure acceptable lateral collision risk in the organized track system environment for a ten-year period from the time of adoption. Before the end of that period, the performance specification will be re-examined in the light of possible changes in the operating environment and equipment technology during that time.

2. COLLISION RISK FORMULA

2.1 It is assumed that the collision rate is related to the lateral overlap probability by the NAT SPG collision risk

formula which relates lateral navigation performance to the risk of collision due to loss of lateral separation. The formula agreed upon by the NAT SPG to represent the lateral collision risk is:

$$N_{ay} = 10^7 P_y (S_y) P_z(0) \frac{\lambda_x}{S_x} \left[E_{y(\text{same})} \left\{ \frac{|\overline{\Delta V}|}{2\lambda_x} + \frac{|\overline{\dot{y}}|}{2\lambda_y} + \frac{|\overline{\dot{z}}|}{2\lambda_z} \right\} + E_{y(\text{opp})} \left\{ \frac{2|\overline{\dot{V}}|}{2\lambda_x} + \frac{|\overline{\dot{y}}|}{2\lambda_y} + \frac{|\overline{\dot{z}}|}{2\lambda_z} \right\} \right] \quad (1)$$

2.2 The parameters used in this equation are defined below and the values used are:

- | | | |
|----------------------|-----------------------|--|
| S_y | = 60 NM | = the lateral separation standard |
| $P_y(S_y)$ | = | the probability of lateral overlap of aircraft nominally flying on laterally adjacent paths (the value of this parameter is calculated below) |
| $P_z(0)$ | = 0.25 | = the probability of vertical overlap of aircraft nominally flying at the same flight level |
| λ_x | = 0.033 NM (= 200 ft) | = the average length of an aircraft |
| λ_y | = 0.033 NM (= 200 ft) | = the average wing span of an aircraft |
| λ_z | = 0.0085 NM (= 50 ft) | = the average vertical dimension of an aircraft |
| S_x | = 120 NM | = a parameter used in the calculation of the E_y values |
| $E_{y(\text{same})}$ | = 0.5 | = the average number of same-direction aircraft flying on laterally adjacent tracks at the same flight level within segments of length $2 S_x$ centred on the typical aircraft |

$E_y(\text{opp}) = 0.013$ = the average number of opposite-direction aircraft flying on adjacent tracks at the same flight level within segments of length $2 S_x$ centred on the typical aircraft

$|\overline{\Delta V}| = 13 \text{ kt}$ = the average relative along-track speed of two aircraft flying at the same flight level in the same direction

$|\overline{V}| = 480 \text{ kt}$ = the average ground speed of an aircraft

$|\overline{\dot{y}}| = 47 \text{ kt}$ = the average relative cross-track speed between aircraft which have lost 60 NM of separation

$|\overline{\dot{z}}| = 1 \text{ kt}$ = the average relative vertical speed of aircraft flying at the same flight level

2.2.1 All the values given above, except those for $E_y(\text{same})$ and $E_y(\text{opposite})$, have been used in all recent calculations of the NAT SPG and are regarded as the best estimates of the operating environment. The values of $E_y(\text{same})$ and $E_y(\text{opposite})$ have been estimated on the basis of the most recent North Atlantic traffic forecasts and on traffic counts made in the North Atlantic in 1973. Total average traffic flow = 400 flights per day (NAT TFG baseline forecast for 1982), of which 350 will cross 20°W or 40°W between 45°N and 65°N , where the traffic counts were made and for which computer simulations were available. The values found for $E_y(\text{same})$ and $E_y(\text{opposite})$, therefore, apply only to this area. As the number of flights on parallel tracks in the MNPS airspace but outside this area can be expected to be much smaller, these values can be regarded as slightly cautious approximations for $E_y(\text{same})$ and $E_y(\text{opposite})$ in the total MNPS airspace.

2.3 Dropping the subscript y from the separation standard, the lateral overlap probability is related to the overlap integral by the defining relation:

$$P_y(S) = 2\lambda_y C(S) \tag{2}$$

so that the overlap integral is given in terms of the lateral deviation distribution $f(Y)$ by:

$$C(S) = \int_{-\infty}^{\infty} f(Y) f(Y + S) dY \tag{3}$$

Here, $f(Y)$ is the probability density function of lateral deviations from course.

2.4 The objective of the minimum navigation performance specification can now be stated in terms of the NAT SPG collision risk formula:

The level of navigation performance in the North Atlantic organized track system shall be such that the risk of collision due to loss of lateral separation does not exceed 0.2 fatal aircraft accidents in 10^7 flying hours.

2.5 Using the values of the collision risk formula parameters given above and $N_{ay} = 0.2$, this objective implies that the maximum allowable level of $C(S)$ is $6.45 \times 10^{-6} \text{NM}^{-1}$. In the estimation of collision risk from observed lateral deviation data the estimation of $C(S)$ is the crucial point of the procedure. Likewise, in the establishment of a navigation performance specification, the primary concern is to ensure via the specification that $C(S)$ will not exceed the maximum allowable value indicated above.

2.6 In the next section, general characteristics of the lateral deviation distribution, $f(Y)$, inferred from data collected to date in the North Atlantic are discussed in terms of the consequent properties of $C(S)$. This discussion leads to the calculation of parameters used in formulating a minimum navigation performance specification for the North Atlantic organized track system.

3. DERIVATION OF THE NUMERICAL VALUES

3.1 During the development phase it was realized that the choice of the parameters, for which limits were to be set in the specification, depended to some extent on the shapes of the distributions of the deviations which could be expected to occur in practice. It has been observed in data collections in the past that the vast majority of aircraft stay within a narrow interval about the centre line $Y = 0$ while the few remaining aircraft execute larger deviations with a frequency which falls off more or less slowly with respect to the magnitude of the deviation. Roughly speaking, these two groups can be distinguished as "normal operations" and "blunders". Secondary peaks can occur at deviations about equal to the separation (due to "ATC loop errors" or errors in the programming of airborne navigation computers) but it is unlikely that they will occur at any other values of the deviation.

3.2 A careful study showed that the best approach to defining the specifications would be to provide limits for:

- a) the standard deviation;
- b) the probability of deviations beyond the half-separation; and
- c) the probability density of the deviations at the separation.

3.3 Taking into account that:

- for any distribution which has a secondary peak at the separation S but meeting the requirement in the specification at that point, the convolution integral will be less than that obtained with a distribution slowly decreasing to the same density at S ; and
- that the limit for the density at S should not be so low that a too long time period would be required to determine whether it is being met,

it can be stated that the mathematical determination of the values for these limits can be based on functions meeting the following requirements:

- a) symmetric with zero mean;
- b) unimodal;
- c) most heavily weighted in the inner (core) region; and
- d) slowly varying and small in magnitude in the outer (tail) region.

3.4 As a consequence of these properties, a simple approximation for $C(S)$ can be developed. Assumptions c) and d) are restated in a different manner, assuming the existence of a positive number $K < S/2$:

$$\int_{|Y| > K} f(Y) dY \ll 1 \quad (4)$$

$$\left| \frac{f^{(m)}(Y)}{f(Y)} \right| \ll \frac{1}{K^m} \quad (\text{for } Y > K \text{ and for all positive integers } m) \quad (5)$$

3.5 When use is made of the four assumptions mentioned above, equation (3) can be more conveniently written as:

$$\begin{aligned} C(S) &= 2 \int_{-\infty}^{S/2} f(Y) f(S-Y) dY \\ &= 2 \int_{-K}^K f(Y) f(S-Y) dY + 2 \int_K^{S/2} f(Y) f(S-Y) dY + \\ &\quad + 2 \int_{-\infty}^{-K} f(Y) f(S-Y) dY \end{aligned} \quad (6)$$

Denote the first term on the right hand side of the equation above by $C_1(S)$. It is the only term which depends on $f(Y)$ for $|Y| < K$, so it is interpreted as the "core-tail interaction".

3.6 The factor $f(S-Y)$ is expanded in a Taylor series about $Y = 0$ (i.e. about $S-Y = S$).

$$\begin{aligned} f(S-Y) &= f(S) - Yf'(S) + \frac{Y^2}{2} f''(S) + \dots + \\ &\quad + \frac{(-Y)^m}{m!} f^{(m)}(S) + \dots \end{aligned} \quad (7)$$

Direct substitution into the formula for $C_1(S)$ gives:

$$\begin{aligned} C_1(S) &= 2 \sum_{m=0}^{\infty} \frac{1}{m!} f^{(m)}(S) \int_{-K}^K (-Y)^m f(Y) dY \\ &\leq 2 \sum_{m=0}^{\infty} \frac{1}{m!} f^{(m)}(S) K^m \int_{-K}^K f(Y) dY \\ &= 2 \left\{ f(S) + \sum_{m=1}^{\infty} \frac{K^m}{m!} f^{(m)}(S) \right\} \int_{-K}^K f(Y) dY \end{aligned} \quad (8)$$

The inequality follows from replacing $(-Y)^m$ by K^m in the integrand, since $(-Y)^m < K^m$ for $-K < Y < K$. Noting that $\int_{-K}^K f(Y) dY \approx 1$, and applying the inequality (5), all but the leading term in equation (8) are negligible and

$$C_1(S) \approx 2f(S) \quad (9)$$

3.7 As a result of the small magnitude and slow variation of the density function in the tail region, the other terms in equation (6) are negligible by comparison with $C_1(S)$ and so:

$$C(S) \approx 2f(S) \quad (10)$$

Using the maximum allowable value of $C(S)$ derived in 2.5, this requirement becomes:

$$f(S) < 3.23 \times 10^{-6} \text{ NM}^{-1} \quad (11)$$

3.8 The quantity $f(S)$ is a measurable function of the navigation performance of the aircraft. It can be approximated by:

$$f(S) \approx \frac{\int_{Y_1}^{Y_2} f(Y) dY}{Y_2 - Y_1} \tag{12}$$

if $Y_2 - S = S - Y_1$.

It must be noted that $2 \int_{Y_1}^{Y_2} f(Y) dY$ is the probability that aircraft will be between Y_1 and Y_2 from the centre line on either side of the track. Using $S = 60$ NM, $Y_1 = 50$ NM and $Y_2 = 70$ NM, equations (11) and (12) can be written as:

$$2 \int_{Y_1}^{Y_2} f(Y) dY = 2 \times 20 \times f(S) = 40 \times 3.23 \times 10^{-6} = 13 \times 10^{-5} \tag{13}$$

or in words:

the proportion of the total flight time spent at lateral deviations from track between 50 and 70 NM shall be less than 13×10^{-5} .

3.9 The value of $f(S)$ determined from the relationship given by equation (10) can be used as a specification of navigation performance. However, a specification in terms of density function alone, both as a guide to manufacturers of navigation systems and as a standard for the measurement of acceptable performance in the track system, would be difficult to implement, since a very large number of lateral deviation measurements is required to demonstrate a navigation system's compliance with the small value of $f(S)$. An alternative specification, employing not only $f(S)$ but also the standard deviation of nominal navigation performance and the probability of lateral deviations at least as large as half separation, can be developed, but a parametric form for the distribution of lateral deviations has to be assumed. The advantage of this specification is that navigation parameters which are more readily adaptable to design goals and performance measurements form a part of the specification, while the restriction on $f(S)$ is maintained. Taking into account the shapes of distributions observed in the past, in which distinct "core" and "tail" regions have often been encountered, the double-double exponential (DDE) function has been chosen to characterize the distribution of lateral deviations from course. This distribution is a weighted sum of two double exponential distributions and has the form:

$$f(Y) = \frac{(1 - \alpha)}{2\lambda_1} e^{-|Y|/\lambda_1} + \frac{\alpha}{2\lambda_2} e^{-|Y|/\lambda_2} \quad (0 < \lambda_1 < \lambda_2 < \infty; 0 \leq \alpha \leq 1) \tag{14}$$

where λ_1 and λ_2 can be thought of as the scale parameters of the core and tails, respectively, in the sense of the "normal operation" and "blunder" interpretation cited previously, with α indicating the relative weight of the tails.

3.10 The standard deviation σ of this distribution is given by:

$$\sigma^2 = 2 \left\{ (1 - \alpha) \lambda_1^2 + \alpha \lambda_2^2 \right\} \tag{15}$$

and the probability of deviation by at least half standard is:

$$\eta = \text{Prob} (|Y| > S/2) = (1 - \alpha) e^{-S/2\lambda_1} + \alpha e^{-S/2\lambda_2} \tag{16}$$

The overlap integral is:

$$C(S) = \left[\frac{1 - \alpha}{2\lambda_1} \right]^2 (S + \lambda_1) e^{-S/\lambda_1} + \left[\frac{\alpha}{2\lambda_2} \right]^2 (S + \lambda_2) e^{-S/\lambda_2} + \frac{\alpha(1 - \alpha)}{2} \left[\frac{1}{\lambda_2 - \lambda_1} (e^{-S/\lambda_2} - e^{-S/\lambda_1}) + \frac{1}{\lambda_1 + \lambda_2} (e^{-S/\lambda_1} + e^{-S/\lambda_2}) \right] \tag{17}$$

3.11 Combinations of the values of λ_1 , λ_2 and α which exactly provide the required value of $C(S)$ (6.45×10^{-6} NM⁻¹) are tabulated in the attached table. The bottom element of each dual number entry is the value of η (denoted by "ETA") corresponding to the specific set of values λ_1 , λ_2 and α . The star signs indicate that at the given value λ_1 no values of λ_2 and α exist, given the definition of

the DDE function, such that the required value of $C(S)$ can be achieved.

3.12 The table shows that η has a minimum of 5.3×10^{-4} . It is proposed to use that minimum as the limit value for the navigation performance. The second requirement can therefore be expressed as:

the proportion of the total flight time spent by aircraft 30 NM or more off track shall be less than 5.3×10^{-4} .

3.13 Analysis has shown that if the two requirements defined in 3.8 and 3.12 are met, the collision risk is relatively independent of the standard deviation of the core. It was nevertheless deemed useful to define a requirement for this standard deviation as a guide to designers of equipment and as a basis for certification tests. Based on previous experience with the parameters of distributions found for similar equipment, a value of 6.3 NM was chosen. This value is equivalent to $\lambda_1 = 4.5$ NM for the core ($4.5 \sqrt{2} = 6.3$).

The third requirement can be expressed as:

the standard deviation of the lateral track errors shall be less than 6.3 NM

It should however be noted that the requirement given in 3.12 may be the more stringent constraint for navigation systems for which the number of errors due to unreliability and ergonomic causes are relatively large.

3.14 In summary, combining the results of both the analyses carried out above, the specification is:

- a) the standard deviation of the lateral track errors shall be less than 6.3 NM;
- b) the proportion of the total flight time spent by aircraft 30 NM or more off track shall be less than 5.3×10^{-4} ;
- c) the proportion of the total flight time spent by aircraft between 50 and 70 NM off track shall be less than 13×10^{-5} .

Table 1

Combinations of LAMDA 1, LAMDA 2, and ALPHA which give the Target Level of C(I)

$$C(I) = 0.00000645280220000$$

SEPARATION STANDARD = 60 NM

LAMDA 2 (NM)		LAMDA 1 (NM)					
		1	2	3	4	5	6
7	ALPHA =	0.186714	0.180122	0.167741	0.142653	0.052536	*****
	ETA =	0.002570	0.002479	0.002347	0.002438	0.003072	*****
8	ALPHA =	0.084147	0.080993	0.075466	0.064634	0.023293	*****
	ETA =	0.001979	0.001905	0.001817	0.002037	0.002969	*****
9	ALPHA =	0.043389	0.041935	0.039447	0.034369	0.012490	*****
	ETA =	0.001548	0.001496	0.001451	0.001760	0.002893	*****
10	ALPHA =	0.025303	0.024580	0.023354	0.020673	0.007615	*****
	ETA =	0.001260	0.001224	0.001207	0.001571	0.002839	*****
11	ALPHA =	0.016300	0.015906	0.015239	0.013663	0.005097	*****
	ETA =	0.001066	0.001041	0.001041	0.001439	0.002799	*****
12	ALPHA =	0.011349	0.011116	0.010721	0.009709	0.003660	*****
	ETA =	0.000932	0.000913	0.000925	0.001845	0.002770	*****
13	ALPHA =	0.008397	0.008249	0.007998	0.007300	0.002776	*****
	ETA =	0.000835	0.000821	0.000841	0.001275	0.002748	*****
14	ALPHA =	0.006517	0.006418	0.006249	0.005738	0.002197	*****
	ETA =	0.000765	0.000753	0.000778	0.001228	0.002731	*****
15	ALPHA =	0.005254	0.005185	0.005065	0.004675	0.001800	*****
	ETA =	0.000711	0.000702	0.000731	0.001183	0.002718	*****
16	ALPHA =	0.004369	0.004318	0.004231	0.003920	0.001517	*****
	ETA =	0.000670	0.000663	0.000694	0.001152	0.002708	*****
17	ALPHA =	0.003726	0.003688	0.003621	0.003367	0.001308	*****
	ETA =	0.000638	0.000632	0.000665	0.001128	0.002699	*****
18	ALPHA =	0.003245	0.003215	0.003163	0.002949	0.001149	*****
	ETA =	0.000613	0.000608	0.000643	0.001108	0.002693	*****
19	ALPHA =	0.002875	0.002852	0.002810	0.002626	0.001026	*****
	ETA =	0.000593	0.000588	0.000625	0.001093	0.002688	*****
20	ALPHA =	0.002586	0.002566	0.002533	0.002371	0.000929	*****
	ETA =	0.000577	0.000573	0.000610	0.001081	0.002684	*****
21	ALPHA =	0.002354	0.002338	0.002310	0.002167	0.000851	*****
	ETA =	0.000564	0.000561	0.000599	0.001071	0.002680	*****

22	ALPHA =	0.002167	0.002153	0.002130	0.002000	0.000787	*****
	ETA =	0.000554	0.000551	0.000590	0.001064	0.002678	*****
23	ALPHA =	0.002012	0.002001	0.001981	0.001863	0.000734	*****
	ETA =	0.000546	0.000543	0.000583	0.001058	0.002676	*****
24	ALPHA =	0.001884	0.001874	0.001857	0.001748	0.000689	*****
	ETA =	0.000540	0.000537	0.000577	0.001053	0.002675	*****
25	ALPHA =	0.001776	0.001767	0.001752	0.001651	0.000652	*****
	ETA =	0.000535	0.000533	0.000573	0.001050	0.002674	*****
26	ALPHA =	0.001684	0.001677	0.001663	0.001569	0.000620	*****
	ETA =	0.000531	0.000529	0.000570	0.001047	0.002673	*****
27	ALPHA =	0.001606	0.001599	0.001522	0.001499	0.000593	*****
	ETA =	0.000529	0.000527	0.000568	0.001046	0.002672	*****
28	ALPHA =	0.001539	0.001533	0.001522	0.001438	0.000569	*****
	ETA =	0.000527	0.000525	0.000567	0.001045	0.002672	*****
29	ALPHA =	0.001480	0.001475	0.001465	0.001385	0.000549	*****
	ETA =	0.000526	0.000525	0.000566	0.001045	0.002672	*****
30	ALPHA =	0.001429	0.001425	0.001416	0.001339	0.000581	*****
	ETA =	0.000526	0.000524	0.000566	0.001045	0.002673	*****
31	ALPHA =	0.001385	0.001380	0.001372	0.001299	0.000515	*****
	ETA =	0.000526	0.000525	0.000567	0.001046	0.002673	*****
32	ALPHA =	0.001346	0.001342	0.001334	0.001263	0.000502	*****
	ETA =	0.000527	0.000526	0.000568	0.001047	0.002674	*****
33	ALPHA =	0.001311	0.001308	0.001301	0.001232	0.000489	*****
	ETA =	0.000528	0.000527	0.000569	0.001049	0.002675	*****
34	ALPHA =	0.001281	0.001277	0.001271	0.001204	0.000479	*****
	ETA =	0.000530	0.000529	0.000571	0.001051	0.002676	*****
35	ALPHA =	0.001254	0.001250	0.001245	0.001180	0.000469	*****
	ETA =	0.000532	0.000531	0.000574	0.001053	0.002677	*****
36	ALPHA =	0.001229	0.001227	0.001221	0.001158	0.000460	*****
	ETA =	0.000534	0.000533	0.000576	0.001056	0.002678	*****
37	ALPHA =	0.001208	0.001205	0.001200	0.001139	0.000453	*****
	ETA =	0.000537	0.000536	0.000579	0.001058	0.002679	*****
38	ALPHA =	0.001189	0.001186	0.001182	0.001121	0.000446	*****
	ETA =	0.000540	0.000539	0.000582	0.001061	0.002680	*****
39	ALPHA =	0.001172	0.001169	0.001165	0.001105	0.000440	*****
	ETA =	0.000543	0.000542	0.000585	0.001065	0.002682	*****

40	ALPHA =	0.001157	0.001154	0.001150	0.001091	0.000435	*****
	ETA =	0.000546	0.000546	0.00589	0.001068	0.002683	*****
41	ALPHA =	0.001143	0.001141	0.001137	0.00079	0.000430	*****
	ETA =	0.000550	0.000543	0.000592	0.001072	0.002684	*****
42	ALPHA =	0.001131	0.001129	0.001125	0.001068	0.000426	*****
	ETA =	0.000554	0.000553	0.000596	0.001075	0.002686	*****
43	ALPHA =	0.001120	0.001118	0.001114	0.001058	0.000422	*****
	ETA =	0.000557	0.000557	0.000600	0.001079	0.002688	*****

Appendix B

Collision Risk Model

1. INTRODUCTION

This appendix describes briefly the main assumptions used in the derivation of the risk model equation that estimates the number of mid-air collisions in a parallel track system with procedural ATC. In its most general form the model can be used to estimate the number of collisions due to loss of planned separation in each of the three dimensions (i.e. lateral, vertical and longitudinal) together with composite separations. However, this appendix will only consider loss of planned lateral separation in a rectangular track system, as used in deriving the MNPS criteria.

2. MAIN ASSUMPTIONS

2.1 All tracks are parallel with a constant spacing S_y

If the tracks are not (completely) parallel, a calculation using the minimum distance between the tracks as S_y , will give a cautious result.

2.2 All collisions occur between aircraft normally on adjacent tracks

It is assumed that the collision risk between aircraft two or more tracks apart is negligible. If there is a significant risk of such large deviations, it will be necessary to estimate separately the risk for single track spacing and each multiple track spacing, taking into account that the other parameters in the model may change (e.g. the occupancy values and the lateral velocities).

2.3 The entry times into the track system are uncorrelated

This is a very important assumption, as can be seen from the following example: if, at each flight level, the aircraft on all tracks entered the parallel tracks at the same time, and flew with the same ground speed, then the true

collision risk might be 3 500 times as large as is calculated by the model. Under other circumstances it might be very much lower than calculated. This assumption will therefore need to be checked while measuring the occupancy prior to MNPS implementation.

2.4 The lateral deviations of aircraft on adjacent tracks are uncorrelated

Though it is not absolutely correct (wind effects during loss of OMEGA signal, the possibility of way-point errors at the same longitude), this is likely to be a reasonable assumption.

2.5 The lateral speed of an aircraft is not correlated with its lateral deviation

It is fairly obvious that this assumption cannot be correct: high lateral speeds must be more likely at large deviations than at small deviations. This assumption provides, however, a very important simplification in the mathematical model, because then only the average lateral speed enters into the equation. A simple solution is, however, possible. As the only lateral speed which is essential here is the average lateral speed of aircraft about to collide, the value of that average speed can be used without affecting the result. Though this solution is simple in theory, it is rather difficult to determine an exact value for it in practice, especially since some causes of lateral navigation errors may have different lateral velocities compared to other types of error.

2.6 There is no corrective action by pilots or ATC when aircraft are about to collide

Since the track system is assumed to use procedural ATC there is clearly no possibility of ATC intervention. However, during MNPS implementation in the NAT region there was considerable discussion of the role of visual avoidance manoeuvres by pilots in reducing the collision risk, some experts regarded it as a very important factor in preventing collisions, others thought that it would only have a minor effect at the relative speeds that might occur in practice. Assuming that there is no corrective action is thus expected to result in a cautious estimate of risk.

2.7 In the collision model the aircraft are replaced by rectangular boxes of equal dimensions

The dimensions of these boxes are the average length, the average span and the average height of the aircraft in the system. This assumption, which considerably simplifies the model, must be regarded as a compromise which takes into account the fact that aircraft accidents are not only due to metal-to-metal contact but can also occur when an aircraft enters the trailing vortex of another aircraft. It is regarded as slightly incautious and to some extent counter-balances assumption 2.6, although the danger due to trailing vortices in high-altitude cruising flight is now

thought to be somewhat less than was thought when the model was originally derived.

3. OTHER FACTORS

In addition to the above assumptions inherent in the risk model itself, values have been assigned to some of the parameters before deriving the MNPS criteria. These have been set at values estimated to be applicable to the NAT region in the mid-1980s (see Appendix A, 2.2). The applicability of these assumed values to the region being considered will need to be reviewed.

— — — — —

Appendix C

Estimation of Occupancy Values and Variation of Risk with Occupancy

1. DEFINITION

1.1 The "same direction, single separation standard, lateral occupancy" for a parallel track system is the average number of aircraft which are, in relation to the typical aircraft:

- a) flying in the same direction as it;
- b) nominally flying on tracks one lateral separation standard away from it;
- c) nominally at the same flight level as it; and
- d) within a defined longitudinal segment centred on it.

1.2 A similar set of criteria can be used to define opposite direction occupancy, and, if required, multiple separation standard occupancies.

1.3 The length of the longitudinal segment, $2S_x$, is fairly arbitrary but appears elsewhere in the risk calculation. In the calculation of occupancy a length equivalent to 30 min of flight time at 480 kt is taken.

2. ESTIMATION OF SINGLE SEPARATION STANDARD LATERAL OCCUPANCY USING TRAFFIC FLOW DATA

2.1 A variety of methods of estimating lateral occupancy have been developed, each with its own advantages and disadvantages in a given situation. The methods presented below are therefore suitable examples of making occupancy estimates.

2.2 The expressed methods have various limitations associated with them. The steady state method (section 3) is the only way to arrive at an estimate of occupancy when only daily traffic counts are available or if, in the direct estimation from time at waypoint passing (section 4), large blocks of time are not available. The latter method probably provides the more accurate estimate of existing occupancy and is the preferred technique for verifying occupancy after a system change has been made.

2.3 For a particular system the lateral occupancy, E_y , is related to two other quantities T_y and H by:

$$E_y = \frac{2T_y}{H} \quad (1)$$

where:

T_y = The total proximity time generated in the system, i.e. the total time spent by aircraft pairs on adjacent flight paths at the same flight level and within a longitudinal distance S_x of each other.

H = The total number of aircraft flying hours generated in the system during the period considered.

3. STEADY STATE FLOW MODEL

3.1 E_y will be estimated for a parallel track system. Initially, assume that the traffic flow onto and along the flight paths is statistically steady during the period considered. For a general system it is necessary to sum over all "steady state" subsystems, weighted by the aircraft flying hours generated in each. (This is discussed later in this appendix.) Number the tracks from 1 to t and the flight levels from 1 to f . The traffic flow on track i , flight level j (flight path ij) is m_{ij} , i.e. m_{ij} aircraft pass each point on the track every hour. The track length is L and all aircraft have velocity V . The system is observed for a time T .

3.2 The number of flying hours H is given by:

$$H = T_x \text{ (average number of aircraft in the system)}$$

Now it takes a time L/V for an aircraft to pass through the system, so on flight path ij there are $m_{ij} L/V$ aircraft at any time. Thus the number of aircraft in the system is:

$$\sum_{i=1}^{i=t} \sum_{j=1}^{j=f} m_{ij} \frac{L}{V}$$

Hence (simplifying the summation):

$$H = \frac{TL}{V} \sum_{\text{all } ij} m_{ij} \tag{2}$$

3.3 T_y is rather more complicated to calculate. Consider an aircraft on flight path i : the expected number of aircraft which are proximate on the adjacent flight path $i-1$, j is equal to:

$$\frac{2S_x}{V} m_{i-1,j}$$

During the time L/V hours of this aircraft's flight the total proximity time generated is therefore:

$$\frac{2S_x}{V} m_{i-1,j} \frac{L}{V}$$

During the T hours for which the system is observed m_{ij} T aircraft pass along flight path ij so the proximity time generated between tracks ij and $i-1$, j is:

$$\frac{2S_x}{V} m_{i-1,j} \frac{L}{V} m_{i,j} T$$

Sum over all such pairs to get the total proximity time T_y :

$$T_y = \sum_{i=2}^{i=t} \sum_{j=i}^{j=f} \frac{2S_x}{V} m_{i-1,j} \frac{L}{V} m_{i,j} T$$

or (simplifying notation):

$$T_y = \sum_{\substack{\text{all pairs} \\ \text{of tracks}}} m_{i-1,j} m_{i,j} 2S_x L T / V^2 \tag{3}$$

Thus we have:

$$E_y = \frac{2T_y}{H} = \frac{\sum_{\substack{\text{all pairs} \\ \text{of tracks}}} m_{i-1,j} m_{i,j} (2S_x/V)}{\sum m_{ij}} \tag{4}$$

3.4 If the system is not statistically steady, as it will not be if there are time dependent flows, the E_y must be calculated by summing over all steady state subsystems. Thus if there are r such subsystems:

$$E_y = \frac{2 \sum_{p=i}^{p=r} T_y^p}{\sum_{p=i}^{p=r} H^p} = \frac{\sum_{p=i}^{p=r} H^p E_{y,p}}{\sum_{p=i}^{p=r} H^p} \tag{5}$$

where we have denoted by a superscript p the particular quantity in subsystem p . T_y^p and H^p can be calculated for each subsystem by the general method we have discussed. For a given amount of total traffic the value of E_y for the system depends critically on the way the system is broken down into steady state subsystems.

4. DIRECT ESTIMATION FROM TIME AT WAYPOINT PASSING

4.1 The method above expresses occupancy as a function of adjacent route-flight level flow rates, average aircraft speed and track length. This formulation depends upon the existence of a statistically steady-state period of traffic movement which is often difficult to define and rarely found when examining data from actual track systems. As a result, a method was developed during the 1960s for estimating occupancy in the North Atlantic organized track system and has found application in other oceanic environments. The method operates upon the flight progress information kept as a part of standard ATC procedures. As a first step in the method, several months of the daily flight progress information for the track system under study is retained. The period covered by the flight progress information for the track system must be sufficiently long to permit a view of any substantial variations in traffic flow caused by seasonal or other factors.

4.2 A sample of enough days from the data to reflect a range of representative daily traffic counts and traffic flow patterns are then chosen for specific analysis. The analysis may be done manually, but is greatly expedited by use of a digital computer. For a given day in the sample, the progress information for all flights is examined and the times reported at each required point in the system are grouped by altitude. The points utilized should be approximately on a plane at right angles to the track system. Reporting times are required for all aircraft transiting the system.

4.3 Each such grouping is then analysed. The objective of the analysis is to determine the number of aircraft pairs at the same flight level on adjacent routes which are within

the distance S_x referenced in the definition of T_y above. Since the determination will be made from the times reported by the aircraft at the required point, this distance is translated into a time interval, 15 minutes being the standard period.

4.4 The analysis of reported times requires that a systematic process for examining reported times on adjacent routes be followed. The process is best explained by an example. Consider a track system consisting of four routes oriented east-west, and denote the tracks from north to south as route 1, route 2, route 3 and route 4. The systematic process requires that reported times of aircraft on route 1 first be compared only to those of route 2. Next, those of route 2 are compared only to those of route 3; times for aircraft on route 1 are specifically excluded from the comparison. Likewise, times from route 3 are compared only with those of route 4. Route 4 times are not used to initiate comparisons with any route.

4.5 The analysis procedure itself is straightforward: two counters, one for each same and opposite direction occupancy, are initialized to zero; the reported time of each aircraft in turn is compared to the reported times of all aircraft on the appropriate laterally adjacent route at the same flight level; whenever the absolute value of the difference between the two times is 15 minutes or less, the appropriate directional counter is incremented by one. After all aircraft have been examined, the counts are multiplied by 2 and divided by the total number of aircraft reporting crossing the plane considered.

4.6 The procedure should be repeated for the day's traffic data at other required reporting points for the aircraft and the results arithmetically averaged. If two required points are deemed to be so close together that the ratios computed from the analysis of each will be unduly correlated, one is dropped from the analysis. Flight progress information from each sample day is treated in the same manner.

4.7 Finally, the entire sample's results are analysed in order to draw inference regarding the behaviour of occupancy as daily traffic count varies. The analysis is usually performed via a univariate statistical regression in which daily traffic count is the exogenous (or independent) variable and daily occupancy estimate the endogenous (or dependent) variable, with the traffic counts and averaged ratios from the sample constituting the empirical information. The result of the analysis is the ability to forecast occupancy as a function of average daily traffic count.

5. VARIATION OF COLLISION RISK WITH OCCUPANCY

5.1 The equation agreed upon by the NAT SPG to represent the number of aircraft accidents due to loss of lateral separation per 10 million en-route flying hours is of the form:

$$N_{ay} = 10^7 P_y(S) P_z(0) \frac{\lambda_x}{S_x} \left\{ E_y(\text{same}) K(\text{same}) + E_y(\text{opp}) K(\text{opp}) \right\}$$

$$\text{where } K(\text{same}) = \frac{|\overline{\Delta V}|}{2\lambda_x} + \frac{|\overline{\dot{Y}}|}{2\lambda_y} + \frac{|\overline{\dot{Z}}|}{2\lambda_z}$$

(6)

$$K(\text{opp}) = \frac{2|\overline{V}|}{2\lambda_x} + \frac{|\overline{\dot{Y}}|}{2\lambda_y} + \frac{|\overline{\dot{Z}}|}{2\lambda_z}$$

and the other parameters have the meanings and values given in Appendix C. The K parameters have the dimension of (Time) and relate to the average aircraft box overlap time.

For the NAT SPG velocity and aircraft size parameters:

$$K(\text{same}) = \frac{13}{2 \times 0.033} + \frac{47}{2 \times 0.033} + \frac{1}{2 \times 0.0085} = 968 \text{ hr}^{-1}$$

$$K(\text{opp}) = \frac{2 \times 480}{2 \times 0.033} + \frac{47}{2 \times 0.033} + \frac{1}{2 \times 0.0085} = 15316 \text{ hr}^{-1}$$

Thus $K(0)$ is about 16 times larger than $K(S)$.

5.2 For the North Atlantic LIM NAT RAN 76 (Doc 9182) we have $E_y(S) = 0.5 E_y(0) = 0.013$. The reason for the large differences in the E_y values is the diurnal pattern of movements, eastbound in the morning and westbound in the afternoon. Thus at most times the track system consists

mainly of same-direction tracks. For the North Atlantic we have:

$$E_y(S)K(S) + E_y(0)K(0) = 0.5 \times 968 + 0.013 \times 15316 = 683 \quad (8)$$

5.3 In the derivation of the NAT MNPS the number of aircraft accidents due to loss of lateral separations was set to a target level of safety of 0.2 accidents in 107 en-route flying hours in order to determine the limit on the overlap probability $P_y(S)$. This probability was in turn used to derive the 50 to 70 NM MNPS criteria. For a system exactly meeting this criteria:

$$0.2 = 10^7 P_y(S) P_z(0) \frac{\lambda_x}{S_x} (683)$$

5.4 For a different region with changed occupancies but the same values of other parameters:

$$N_{ay} = 10^7 P_y(s) P_z(0) \frac{\lambda_x}{S_x} \left\{ E_y(\text{same}) 968 + E_y(\text{opp}) 15316 \right\}$$

$$= \frac{0.2 \left\{ E_y(\text{same}) + 968 + E_y(\text{opp}) \times 15316 \right\}}{683}$$

and the ratio of the number of accidents to the target level of safety becomes:

$$\text{Ratio} = \frac{968 E_y(\text{same}) + 15316 E_y(\text{opp})}{683}$$

It will be seen that this ratio is very sensitive to the relative values of the same and opposite-direction occupancies.



Appendix D

Description of the Radar Monitoring Method Used by a Typical ATS Unit in the NAT Region

Note.— The method described here resembles closely that used by other ATC units. It is therefore included for information.

1. CENTRE PROCEDURES

1.1 A member of the control staff monitors westbound targets entering radar coverage in the NAT area.

1.2 The target is identified and the position determined by range and azimuth from the radar station.

1.3 The position is plotted and the across track deviation measured perpendicular to the cleared track of the flight to obtain the distance off track.

1.4 If the measured distance is less than 25 NM, no further action is taken.

1.5 If the measured distance is 25 NM or more, the details are logged for subsequent action by supervisory staff and the pilot of the aircraft observed is informed of the apparent deviation, whenever this is possible. Any comments by the pilot at the time will be recorded.

2. ACTION BY THE SUPERVISORY STAFF

2.1 Teletype message sent to operator, State of Registry, and regional and national ATS headquarters.

2.2 When deviations of 25 NM or more have been logged, a brief letter is sent to the operator concerned, within 24 hours where possible, providing relevant details and requesting the operator to investigate and comment on the apparent deviation.

2.3 A copy of the letter to the operator is forwarded to the ATS national headquarters and regional headquarters for information. The operator is requested to reply to the national headquarters.

2.4 A monthly summary is sent to the ATS national headquarters showing the number of observations taken during the month and relevant details of those observed to be 25 NM or more off cleared track.

3. ACTION BY NATIONAL HEADQUARTERS

3.1 Copies of letters sent by the ACC to operators, together with replies are reviewed. Certain States of Registry of the aircraft concerned may be notified of the circumstances of the apparent deviation.

3.2 Copies of all signals, letters, etc. relating to observed deviations of 25 NM or more are sent to the central monitoring agency on a monthly basis, together with data concerning the volume of traffic observed.

— — — — —

Appendix E

Provisions Regarding Follow-up Action on Observed and Reported Deviations in the NAT Region

Note.— The following material was developed by the NAT SPG.

1. NOTIFICATION BY THE OBSERVING AUTHORITY

1.1 Taking into account that slightly different administrative arrangements within the States engaged in monitoring will exist, follow-up action on observed deviations from track by 25 NM or more should, in general, be as follows:

1.1.1 For aircraft operating within MNPS airspace:

- a) the observing ATC should, if at all possible, inform the pilot of the aircraft concerned of the observed error and also that an error report will be processed; any comment made by the pilot at the time of notification should be recorded;
- b) all operators, including military, and other relevant area control centres should be notified, either directly by the observing ATC unit or by any other agency designated by the States concerned, by the speediest means available (telephone, AFTN, telex as appropriate) and with the least possible delay of the observed deviation (specimen of such a message is shown in Attachment 1). This should be followed as soon as possible by a written confirmation (a specimen letter of confirmation is shown in Attachment 2). All notifications should be copied to the central monitoring agency.
- c) States of Registry of the operator concerned should receive a copy of the written confirmation (a specimen of the covering letter to State of Registry is shown in Attachment 3), and, if so indicated to the monitoring authority, of the AFTN telex notification.

Note.— Canada, Denmark, France, Iceland, Ireland, Norway, Portugal, Sweden, the United Kingdom, and the United States have already stated this requirement. (Deviations involving SAS flights need only be addressed to Sweden.)

1.1.2 For aircraft operating outside MNPS airspace:

- a) the observing ATC unit should, if at all possible, inform the pilot of the aircraft concerned of the observed error and also that an error report may be processed; any comment made by the pilot at the time of notification should be recorded;
- b) where the observed deviation from track is 25 NM or more, but less than 50 NM, the observing ATC unit, or other agency designated by the State having responsibility for the observing ATC unit, should notify the central monitoring agency of the deviation with the least possible delay (AFTN, telex) using the message format shown in Attachment 1. This should be followed as soon as possible by a written confirmation (a specimen of the letter to the State of Registry is shown in Attachment 4). The central monitoring agency will then advise the State of Registry if that particular State had indicated a requirement for notification of such errors or if the circumstances of the error require further investigation;
- c) where the observed deviation from track is 50 NM or more the procedure detailed in 1.1.1 b) and c) will be followed.

2. FURTHER FOLLOW-UP ACTION BY THE OPERATOR AND/OR STATE OF REGISTRY

Subsequent follow-up action on observed deviations of 25 NM or more, notified in accordance with the above provisions, should initially be conducted between the operator and a designated agency of the State having responsibility for the ATC unit which observed the deviation on the understanding that:

- a) the errors outlined in 1.1.2 b) (i.e. deviations greater than 25 NM or more but less than 50 NM occurring outside the MNPS airspace) will not normally require further action. If an investigation is deemed necessary it will be conducted by the State of Registry;

- b) monitoring States may, if they so wish, request the assistance of other States in monitoring activities;
- c) the State of Registry of the operator concerned should be requested to conduct further investigation if deemed necessary;
- d) all correspondence should be copied to the central monitoring agency;
- e) the ICAO European Office will assist in those cases where no response is obtained from either the operator concerned or the State of Registry.

— — — — —

ATTACHMENT 1

**MESSAGE FORMAT FOR THE INITIAL NOTIFICATION OF
OPERATORS AND/OR STATES OF REGISTRY AND THE
CENTRAL MONITORING AGENCY OF AN OBSERVED DEVIATION**

1. The following format should be used for messages serving as an initial notification of an observed deviation of 25 NM or more from track.
2. This format should be used regardless of the means of communication chosen for the transmission of the initial notification.

GROSS NAVIGATION ERROR MESSAGE

REPORTING AGENCY

DATE

TIME

AIRCRAFT IDENTIFICATION (and operator if not evident from identification)

LOCATION AND EXTENT OF OBSERVED DEVIATION

FULL REPORT FOLLOWS

PLEASE ACKNOWLEDGE RECEIPT

SIGNATURE

ATTACHMENT 2

FORMAT OF WRITTEN CONFIRMATION TO OPERATORS OF AN OBSERVED DEVIATION

1. The following is the agreed format of the written confirmation which should be sent to operators following their initial notification. This written confirmation should be sent as soon as possible after the observed deviation to permit investigation while records are still available. It should consist of the letter shown hereafter and *two copies* of the error investigation form, one of which is intended for retention by the operator. If no initial notification could be sent the written report should nevertheless be made in the same way.

Dear Sir,

States responsible for the provision of air traffic services in the North Atlantic region have been instructed by ICAO to monitor and notify operators and States concerned of aircraft deviations of 25 NM or more from assigned track so that they may take prompt and effective action to prevent a repetition.

A gross navigational error has been reported in respect of the following flight:

Aircraft identification:

Type:

Departure:

Destination:

Date:

Cleared track:

Flight plan track:

Actual track (if known):

Cleared flight level:

The notification should then contain information on the following:

- Radar observed position and time.
- Displacement from cleared track.
- Action taken by ATC (if any).

Comments by crew on being notified of error:

Other comments:

Detailed explanation should be provided on the attached error investigation form and an investigation of this gross navigational error is requested. In your reply, you are also requested to indicate the corrective action taken.

Yours faithfully,

2. Specimen format for error investigation form:

REPORTING AGENCY	REPLY ADDRESS																			
PLEASE COMPLETE PART 2 (AND PART 3 IF APPLICABLE) OF THIS FORM AND RETURN ONE COPY TOGETHER WITH COPIES OF RELEVANT FLIGHT DOCUMENTATION (FUEL FLIGHT PLAN, ATC FLIGHT PLAN AND ATC CLEARANCE) TO THE ABOVE REPLY ADDRESS WITH THE LEAST POSSIBLE DELAY. THANK YOU FOR YOUR CO-OPERATION.																				
PART 1	<p>OPERATOR'S NAME:</p> <p>AIRCRAFT IDENTIFICATION:</p> <p>DATE AND TIME OF OBSERVED DEVIATION:</p> <p>POSITION AND EXTENT OF OBSERVED DEVIATION:</p> <p>OBSERVED BY: (state radar unit)</p> <p>FLIGHT LEVEL:</p>																			
PART 2	<p>2.1 Type and number of navigation equipment on board aircraft (mark as appropriate). (Please indicate system used for steering.)</p>	<table border="1" style="width:100%; border-collapse: collapse;"> <tr> <td style="text-align:center;">INS</td> <td style="text-align:center;">OMEGA</td> <td style="text-align:center;">DOPPLER</td> <td style="text-align:center;">OTHER (specify)</td> </tr> <tr> <td style="text-align:center;">Single Dual Triple</td> <td style="text-align:center;">Single Dual</td> <td style="text-align:center;">Single Dual</td> <td></td> </tr> <tr> <td style="text-align:center;">Model</td> <td style="text-align:center;">Model</td> <td style="text-align:center;">Model</td> <td></td> </tr> <tr> <td style="text-align:center;">Programme</td> <td style="text-align:center;">Programme</td> <td></td> <td></td> </tr> </table>	INS	OMEGA	DOPPLER	OTHER (specify)	Single Dual Triple	Single Dual	Single Dual		Model	Model	Model		Programme	Programme			<p>2.2 Give detailed description of incident including your assessment of the track of the aircraft while in MNPS airspace and duration of any equipment failure. (Continue overleaf if required.)</p>	
INS	OMEGA	DOPPLER	OTHER (specify)																	
Single Dual Triple	Single Dual	Single Dual																		
Model	Model	Model																		
Programme	Programme																			
PART 3	<p>(Only to be completed in case of partial or full navigation equipment failure.)</p> <p>Indicate number of equipment units which failed INS OMEGA DOPPLER OTHER</p> <p>Circle estimated longitude (to nearest 5 degrees) at time of failure: 60W 55W 50W 45W 40W 35W 30W 25W 20W 15W 10W 5W 00</p>																			

ATTACHMENT 3

FORMAT OF COVERING LETTER TO STATE OF REGISTRY

Dear Sir,

North Atlantic — Gross navigation error

Please find attached a copy of a letter that has been sent in respect of a North Atlantic gross navigation error attributed to an aircraft registered in your State. You will note that the operator has been requested to provide an explanation of the incident; this is in accordance with the NAT monitoring procedures set out in the ICAO Document T13/5N — “Guidance and information material concerning air navigation in the NAT region” prepared and distributed by the ICAO European Office.

Should the operator fail to reply to the request a further letter will be sent to you seeking your assistance in obtaining the information requested.

*It would be appreciated if you would confirm that the flight in question was in possession of approval to operate in MNPS airspace (ICAO Doc 7030 — NAT Chapter 2, and ICAO State Letter ... refers).

Yours faithfully,

* This paragraph to be omitted if the aircraft did not operate in MNPS airspace.

Appendix F

Provisions Regarding the Reporting by Pilots of the Performance of INS and OMEGA Equipment in the NAT Region

Note.— The following material was developed by the NAT/SPG (1977).

1. States of Registry requiring operators to use a specific form to record the performance of INS and OMEGA navigation equipment should consider very carefully what it is that they are endeavouring to check. States are most likely to be interested in a form which serves several purposes. In the case of INS equipment this might:
 - a) warn of deteriorating INS accuracy;
 - b) provide a simple record which will facilitate a retrospective analysis for those cases where a radar-observed deviation from track has been reported;
 - c) provide a general picture of performance of flights while operating in areas where no radar coverage is provided.
2. In the case of OMEGA, cases have been reported where the metallic structure of a terminal building adversely affected OMEGA navigation read outs. It may, therefore, be more appropriate to record readings:
 - a) shortly after landing and before taxiing at the arrival airport is started; or
 - b) over land-fall point after an ocean crossing.
- 2.1 Such readings as mentioned above give a less reliable picture of the over-water performance than is the case with INS. However, they are nevertheless likely to indicate whether a large error has developed such as might result from a "lane-slip".
3. The more complicated a form is, the more problems are likely to be encountered, both in getting it completed and having it analysed. Therefore, two forms, one for INS, and the other for OMEGA, might eventually be justified. However, the specimen form shown below does combine the two, and if only OMEGA performance is being recorded, Columns 14, 15 and 16 should be ignored.
4. Following is a specimen format of a pilot report form used in the NAT region.

Appendix G

Compliance with Specifications of Minimum Navigational Performance as Conditions for Operation in Specified Portions of the Airspace

Note.— The following material is extracted from the report of the Ninth Air Navigation Conference, ICAO Doc 9168, (pages 2-5 to 2-10 refer).

1. GENERAL ASPECTS

1.1 The quality of navigational performance required in aircraft operation is based on the need for flights to be conducted from one place to another with safety and economy. Under conditions of dense air traffic, or airspace constraints, it may become necessary to precisely define the required accuracy of adherence to a particular track and establish this as a condition for operating on a certain route.

1.2 The required level of performance of a navigation system may not be constant throughout the world since the required accuracy will necessarily relate to the particular air traffic environment as well as to the manner in which ATS is provided.

1.3 No one statement of operational requirements, although meeting the basic requirements of safety, can adequately reflect the many different combinations of operating conditions encountered in various parts of the world. It will be evident, however, that although the requirements applicable within the most exacting portions of regions may be rather extravagant when applied elsewhere, it is necessary to establish them as the most stringent specifications which would permit aircraft to be operated on any established route. Thus, while failure to meet such a specification might result in the exclusion of aircraft from particular routes, operation might reasonably be permitted elsewhere. The guidance material following is, therefore, designed towards establishing a broad framework of information for both manufacturers of equipment and operators of aircraft and permitting, by means of appropriate regional agreements, the establishment of performance specifications which must be met as conditions of operation on designated routes or route structures.

1.4 In determining criteria for system performance, it is evident that there must be an ability to provide for oper-

ation in specific areas while permitting the application of separation minima necessary so as to accommodate present and forecast traffic. It is also desirable that the criteria established should be protected for a period of at least a decade after any stated date of implementation of particular values, thus assuring the cost-effectiveness to operators of the equipment necessary to ensure the required level of performance.

1.5 There is no operational need for international standardization in terms of the equipment selected by individual operators. The essential provision is that the combinations selected and the way they are used by an operator must together be capable of meeting the navigation performance specifications in that portion of the region in which flight operations occur.

2. SYSTEM PERFORMANCE REQUIREMENTS

2.1 Basic requirements

2.1.1 Inherent in any statement of minimum performance requirements for a navigational system are the following conditions:

- a) in an air traffic environment in which there is a multiplicity of tracks, the ideal aim would be that no aircraft should cross the half-standard minimum separation value established between any two tracks, thus ensuring that aircraft operating on another track are not placed at risk of collision. The need is to ensure that the very large majority of the traffic is concentrated close to the designated track and that any deviations, whether the product of inadequate performance of a particular system or of human error, are contained before reaching the half-standard thus avoiding the possibility of a collision occurring in the locality. Absolute perfection in such achievement is likely to be impossible. Statements of performance requirements will therefore relate to an error distribution which results in an acceptable level of safety for the environment under consideration;

b) in other airspace, there is a need to ensure that aircraft adhere to the cleared track and remain within any protected airspace which may be provided. The conditional requirements are related to the need to avoid risk of collision with any traffic which may be operating outside but adjacent to the protected airspace and to avoid disruption of other traffic flows. Such adherence is also an essential requirement in the context of ensuring the safety of any ATS action regarding crossing traffic where the minima need to be kept at the lowest possible value to avoid unnecessary delays and also to avoid unnecessary alerts.

2.1.2 In addition to the above operational requirements regarding over-all performance it is also necessary that the Operations Manual must contain such pertinent material as required to define all operational limitations associated with the performance of the system. For example, in the case of a station-referenced system, details of the areas in which an adequate level of signals may be received, or, in the case of an inertial system, any limitations of the ground alignment of the system and of the period of time within which adequate navigational performance within specified limits can be reasonably assured.

2.1.3 It is also essential that any requirements established shall take account of cost-effectiveness considerations and the "best operating practices" which are achieved by the majority of the operators in a given area. To this end it is essential that aircraft equipment required to establish particular levels of performance shall be available to all operators.

2.2 Essential operating procedures

2.2.1 Experience has clearly demonstrated that the provision of sophisticated navigational equipment on board aircraft does not, by itself, ensure that a high level of performance will be achieved. Thus, two operators might have identical equipment which might suggest that they would achieve similar performance but this will not be the case unless the equipment is properly maintained and used in a proper manner by the operating crews.

2.2.2 It is, therefore, essential that the operational use of any navigational system has an adequate back-up in terms of proven maintenance facilities, adequate training for the personnel operating or maintaining the equipment, and mandatory operating drills and procedures.

Note.— For instance, in the case of way-point data insertions, flight-deck cross-check procedures have been effective in reducing the incidence of blunder-type errors.

2.3 Evaluation programme and operational approval

2.3.1 In most cases, operators will be able to select from installation equipment for which performance capability has already been established to the satisfaction of a State of Registry, and the primary concern will therefore be in establishing that the end product of performance of the system is of the highest order. Where, however, a completely new system is proposed for use or major changes have been made in the technology of an existing system, an evaluation will be necessary to establish the quality of performance before authorization for use as a primary system.

2.3.2 Where such an evaluation is required, normal navigational performance must be assured by the carriage of a system having current approval in addition to the new system being evaluated. Any evaluation programme must provide data on sufficient flights to demonstrate to the satisfaction of the appropriate authority:

- a) the accuracy and reliability required to establish compliance with the appropriate navigation performance specification;
- b) the adequacy of operational procedures;
- c) the adequacy of maintenance arrangements;
- d) the adequacy of operations and maintenance training programmes.

2.3.2.1 The amount of flying required to complete an evaluation will vary with the type of installation, the experience of the manufacturer or other operators with the equipment and the results which have been obtained.

2.3.3 The process of operational approval of a new system, after its airworthiness certification, will generally consist of the following phases:

- a) manufacturers' trials and trials on board the aircraft in the regional environment concerned, with the basic navigational requirement being met by an existing approved system. Previous valid evaluation programme data may be used;
- b) confirmatory flights by the Flight Standards Organization of the State of Registry, after establishing that the over-all standards of accuracy and reliability appear acceptable, to establish that adequate operating drills/procedures and training facilities have been established leading to conditional approval for use in the environment;
- c) operational use in the environment but with close monitoring to ensure that the initially approved level of performance is being maintained.

2.3.4 In the event that the performance of a system falls significantly below the requirement during this latter period, the State of Registry will need to consider whether remedial action in terms of improvement to the equipment or flight-deck drills is possible, or whether the aircraft may need to be temporarily excluded from the system. This latter consideration is of significant importance, as the only alternative may be to increase the separation values currently applied, thus creating a considerable economic burden for other operators.

2.4 Limitations to the approval of equipment

2.4.1 Separately from the determination of the total performance of a system established in accordance with 2.3.2 above, it is necessary to take into account the limi-

tation of particular types of navigation systems. The need is to ensure that in the event of partial system failure the remaining equipment is sufficient to enable the aeroplane to navigate in accordance with the conditions of its original or amended clearance. To assist in meeting this requirement a specification of the equipment to be available and serviceable at entry into the airspace concerned is essential.

2.4.2 To simplify regulatory procedures, States may wish to establish performance criteria for routes and/or geographical areas on a world-wide basis. Such an approach will obviate the need for detailed negotiations on each occasion that an operator may wish to extend its route approvals. In exercising such options it will be for the State concerned to ensure that regional specifications of performance are met and that in cases where no specific requirements have been established, at least the minimum conditions suggested in 2.1.1 b) are taken into account.

AIR TRAFFIC SERVICES PLANNING MANUAL

PART II

SECTION 3. ATS SYSTEMS DEVELOPMENT

SECTION 3

ATS SYSTEMS DEVELOPMENT

Contents

	<i>Page</i>		<i>Page</i>
Chapter 1. Airspace Sectorization	II-3-1-1	Chapter 3. Application of Automation in Air Traffic Services.....	II-3-3-1
1.1 Introduction.....	II-3-1-1	3.1 Introduction.....	II-3-3-1
1.2 Approach control.....	II-3-1-2	3.2 Management considerations.....	II-3-3-1
1.3 Area control centre.....	II-3-1-2	3.2.1 Need for automation.....	II-3-3-1
1.4 Consolidation of sectors.....	II-3-1-2	3.2.2 Long-term planning.....	II-3-3-2
Chapter 2. Use of Radar	II-3-2-1	3.2.3 Human factors.....	II-3-3-4
2.1 Introduction.....	II-3-2-1	3.2.4 Controller contributions.....	II-3-3-4
2.2 Primary surveillance radar.....	II-3-2-2	3.3 ATC system considerations.....	II-3-3-5
2.3 Secondary surveillance radar.....	II-3-2-2	3.3.1 ATC analysis.....	II-3-3-5
2.3.1 General.....	II-3-2-2	3.3.2 Automation as a part of a balanced system.....	II-3-3-5
2.3.2 The interrogator/transponder system.....	II-3-2-3	3.3.3 Relations to ATS communications	II-3-3-5
2.3.3 Modes.....	II-3-2-3	3.4 Automation project considerations.....	II-3-3-6
2.3.4 Codes.....	II-3-2-3	3.4.1 System design and development..	II-3-3-6
2.3.5 Limitations.....	II-3-2-4	3.4.2 Installation and testing.....	II-3-3-7
2.3.6 Allocation and use.....	II-3-2-4	3.5 Data processing in ATS.....	II-3-3-7
2.4 Precision approach radar.....	II-3-2-6	3.5.1 Applicability.....	II-3-3-7
2.5 Performance of radar equipment.....	II-3-2-6	3.5.2 Flight plan data processing.....	II-3-3-7
2.6 Radar glide paths.....	II-3-2-6	3.5.3 Radar data processing.....	II-3-3-9
2.6.1 Establishment of glide path.....	II-3-2-6	3.5.4 Integration of processed flight plan and radar data.....	II-3-3-10
2.6.2 Computation of levels.....	II-3-2-7	3.5.5 MET and AIS data processing...	II-3-3-11
2.6.3 Rates of descent.....	II-3-2-7	3.5.6 Data recording and analysis.....	II-3-3-11
2.7 Integration of radar and non-radar services.....	II-3-2-8	3.5.7 Communications.....	II-3-3-12
2.8 Integration of SSR into the ATC radar system.....	II-3-2-9	3.5.8 Simulation.....	II-3-3-13
2.8.1 General.....	II-3-2-9	3.6 Man-machine interface.....	II-3-3-13
2.8.2 Integration process.....	II-3-2-10	3.7 System reliability and availability.....	II-3-3-14
2.9 Application of radar separation.....	II-3-2-10	3.8 Data interchange.....	II-3-3-15
2.9.1 General.....	II-3-2-10	3.8.1 Data interchange between ATS units.....	II-3-3-15
2.9.2 Reduction of minima.....	II-3-2-11	3.8.2 Data interchange with other systems.....	II-3-3-16
2.9.3 Use of SSR data.....	II-3-2-12	3.9 Further automation.....	II-3-3-17
2.10 Separation based on computer-processed radar data.....	II-3-2-12	3.9.1 Extended application.....	II-3-3-17
2.10.1 Technical considerations.....	II-3-2-12	3.9.2 Technological developments.....	II-3-3-17
2.10.2 Operational considerations.....	II-3-2-15	3.9.3 Growth potential.....	II-3-3-18
		Appendix A. Glossary.....	II-3-3-20

	<i>Page</i>		<i>Page</i>
Chapter 4. ATS Data Management	II-3-4-1	4.3.4 Operation	II-3-4-2
4.1 Introduction.....	II-3-4-1	4.4 Methods of ATS message exchange	II-3-4-3
4.2 Use of flight plans	II-3-4-1	4.5 Flight data presentation	II-3-4-4
4.2.1 Submission and acceptance of flight plans	II-3-4-1	4.5.1 Flight progress strips.....	II-3-4-4
4.3 Repetitive flight plans	II-3-4-2	4.5.2 Operation of the flight progress system	II-3-4-5
4.3.1 General	II-3-4-2	Appendix A. Terms, methods and symbols used in relation to the flight progress strip marking system	II-3-4-6
4.3.2 Basic requirements.....	II-3-4-2		
4.3.3 Implementation	II-3-4-2		

Chapter 1

Airspace Sectorization

1.1 INTRODUCTION

1.1.1 The air traffic control (ATC) system must be adaptable to temporary as well as more permanent changes in air traffic volume and composition. Usually an increase in air traffic results in an increase in the controller's workload and if overload situations are anticipated to re-occur and for prolonged periods, a re-distribution of responsibilities may be necessary. The airspace may therefore be divided into sectors within which air traffic services (ATS) are provided by one or more ATS operating positions. Normally a sector is part of a control area and/or a flight information region (FIR)/upper information region (UIR). It could also be a terminal control area around major aerodromes within which specific approach functions are performed.

1.1.2 When reviewing the need for the division of the airspace into sectors the following factors should be considered:

- a) the configuration of the ATS route network;
- b) the amount and mix of air traffic;
- c) the geographical distribution of traffic;
- d) the capacity of the ATS personnel.

1.1.3 When assessing the ATS route network configuration, the following factors should be taken into account:

- a) number of ATS routes served;
- b) number of intersections of ATS routes;
- c) the proportions of aircraft in level flight and in climb or descent;
- d) significant aircraft performance characteristics.

1.1.4 In addition, limitations in the air-ground communication and radar coverage in specified portions of the airspace may have an impact on the sector configuration.

1.1.5 When assessing the amount of traffic in a sector, it should be done in relation to the following factors:

- a) peak hourly traffic load, which is the traffic load to be handled in that clock hour during which the highest number of movements occurs. This peak hourly traffic load should be derived from traffic data collected during an average day of the peak week of the year;
- b) maximum instantaneous traffic load, which is the traffic load at the busiest instant within the peak hour as determined above.

1.1.6 At present there is no generally accepted method for the assessment of controller capacity. However, work on this subject has been conducted by a number of States. The method developed in the United Kingdom, which is similar to the United States' method, is based on an over-all assessment of workload (on an arbitrary scale) made by an observer who is himself an experienced air traffic controller, normally having controlled traffic in the sector under review. The assessments are then related statistically to the traffic flow, from instant to instant.

1.1.6.1 The main difficulty in making an assessment is determining an acceptable normal workload. However, from experience gained during overload conditions this assessment can be estimated if the capacity of one sector is known. The capacity of the remaining sectors can then be determined.

1.1.7 Before a decision is taken to introduce sectorization, or to increase the numbers of sectors, it should be realized that such a step may not, in all cases, result in an increase of capacity and/or efficiency since the associated increased need for co-ordination between controllers may create such an additional communication workload that the expected benefits remain insignificant. One alternative may be to increase the efficiency of each existing operating position, thus reducing the over-all workload and increasing capacity without the need to increase the number of operating positions. To accomplish this, changes to the traffic flow, control methods used, and the provision of additional technical aids, such as radar, automation, etc., should be considered.

1.2 APPROACH CONTROL

(Note.— See also Part I, Section 2, Chapter 8.)

1.2.1 The number of aircraft that can be simultaneously controlled by one operating position in approach control (APP) is normally significantly less than that which can be controlled by an operating position in an area control centre (ACC). This condition results from the fact that, in terminal areas, aircraft enter into a more complex phase of their flight, the number of crossings of flight paths is greater, and the proximity of other aerodromes and the combinations of runways in use at any one time tend to complicate the traffic flow. The division of responsibility between an ACC and the associated APP should therefore be made so as to provide for an optimum utilization of the total available ATC capacity and the sectorization in both units should be adjusted accordingly.

1.2.2 The following factors should be taken into account when designing APP sectorization:

- a) ATS route structure, entry and exit points, intersections, holding points;
- b) aerodromes and runway configurations to be served by the sectors;
- c) flight profiles;
- d) navigation tolerances on ATS routes concerned and for holding areas;
- e) airspace required for ATC initiated flight paths, i.e. vectoring areas;
- f) routing and flight levels for transiting air traffic;
- g) control methods applied to air traffic within the sector;
- h) factors influencing the division of responsibilities and co-ordination between APP and other units; and
- i) physical considerations (operational positions, communication and/or radar coverage, etc.).

1.3 AREA CONTROL CENTRE

(Note.— See also Part I, Section 2, Chapter 8.)

1.3.1 The number of aircraft that can be controlled by any one operating position in an ACC depends to a large degree on the structure and utilization of ATS routes served by that position. In a sector where the majority of traffic handled is in level flight and operates along ATS routes used for one-way traffic only, the controller's capacity is significantly higher than in a sector which includes a number of crossing points, where level changes

are frequent and opposite-direction air traffic has to be controlled, or where the route network covered by the sector extends over a large geographical area.

1.3.2 ACC sectorization should be adapted to the major route structure. Each sector should cover as much as is feasible of a main route segment with the aim to keep the need for co-ordination and radio frequency changes to a minimum. In those cases where traffic is made up of a significant number of overflying aircraft in the upper airspace, a vertical split (upper and lower airspace sectors) should be considered.

1.3.3 The ACC sectors should, in addition to the ATS route structure, also cover required holding areas (high and intermediate). The airspace required for navigation along the routes and in holding areas within a sector should be completely encompassed by that sector.

1.3.4 Due regard should also be given to the descent phase of flight. Air traffic descending for approach normally requires more attention from the controller than other flight phases and care should be taken not to overload a sector controller by including an excessive number of such descent paths within a sector.

1.3.5 Limitations in the physical organization of the controller's operational positions and associated equipment and in communication and radar coverage should be taken into account in determining the sector configuration.

1.3.6 To keep co-ordination to a minimum the division of the airspace of one ATS unit into sectors should be such that it corresponds to the adjacent peripheral sectors of an adjacent ATC unit, i.e. the sector in one unit should normally not be required to co-ordinate with more than one sector of the adjacent unit.

1.4 CONSOLIDATION OF SECTORS

Air traffic demand within portions of the airspace may vary considerably during the year or day. The ATS system should be adaptable to such variations in traffic. Arrangements should therefore be made to allow for the consolidation of sectors whenever traffic permits this to be done (e.g. at night). This will permit a reduction in the number of controllers required to be on duty during such periods. The technical arrangements for air-ground and ground-ground communications and for radar surveillance and the data flow arrangements should envisage this possibility without the need for major changes.

Chapter 2

Use of Radar

2.1 INTRODUCTION

2.1.1 As the air traffic control (ATC) system has developed throughout the world, radar has become one of the more important tools used by air traffic controllers in providing for a safe, orderly and expeditious flow of air traffic. The types of radar used for this purpose are primary surveillance radar (PSR) and secondary surveillance radar (SSR).

2.1.2 ATC radar, in its simplest form, provides the controller with a visual indication on a cathode-ray tube (CRT) of all radar echoes reflected from aircraft within line-of-sight of the ground-based surveillance radar facility. This type of radar is known as primary surveillance radar. The display presented to the controller provides information on the range and azimuth of reflecting objects, including aircraft, within line-of-sight and in relation to the location of the ground equipment and, due to the periodic renewal of the information, also presents an indication of the aircraft's progress in the horizontal plane.

2.1.3 SSR is composed of ground interrogator and airborne transponder equipment. The ground interrogator equipment is normally co-located with a primary radar, so that targets acquired by the primary radar and those by SSR are presented simultaneously on the controller's radar display and will normally appear as one single target. In addition to providing position information, SSR provides a limited data link for transmission of information from the aircraft to the ground station utilizing an encoder in the aircraft and a decoder on the ground (see Figure 1).

2.1.4 The cost of radar equipment involved is high, therefore the decision to provide ATC with radar cannot be based on traffic density or complexity alone but should also take account of cost-benefit considerations (see Part III, Section 1, Chapter 1, 1.2). Future expansion of the use of ATC radars, both as regards the area covered and the degree of sophistication, should be taken into account at the time initial planning for such facilities takes place.

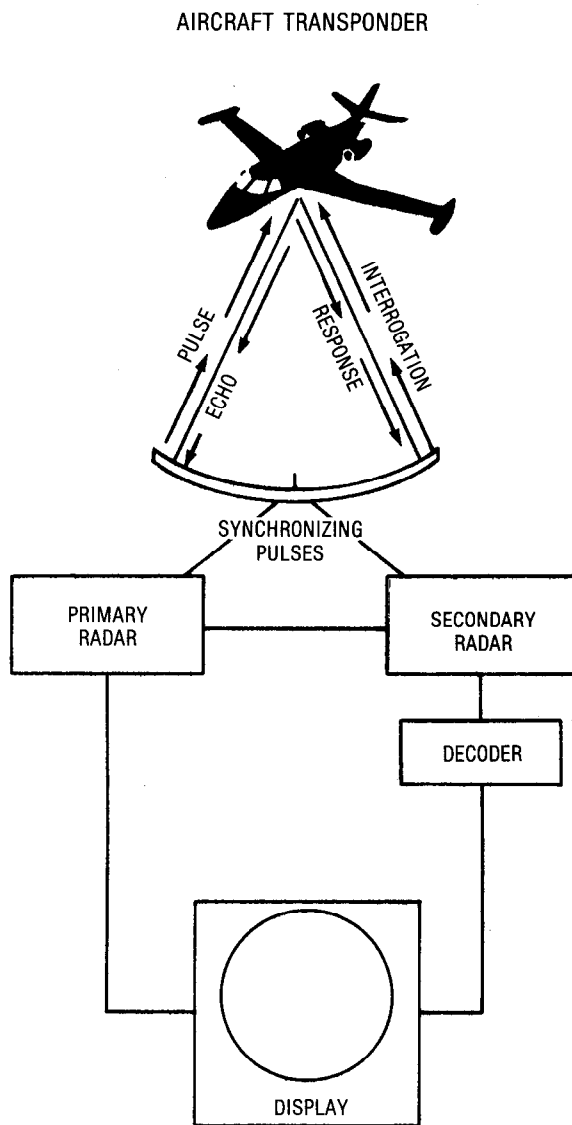

Figure 1.— Principles for radar signal transmission

2.2 PRIMARY SURVEILLANCE RADAR

2.2.1 Primary surveillance radars (PSRs) may be divided into two categories; terminal surveillance radars (up to 116 km (60 NM)) and en-route surveillance radars (more than 185 km (100 NM)). The terminal surveillance radar is designed to provide for relatively short-range coverage in the general vicinity of one or more adjacent aerodromes and to serve as an aid to the expeditious handling of traffic in the terminal control area (TMA). It may also be used as an aid to instrument approaches. The en-route surveillance radar is a long-range radar system designed primarily to provide information on aircraft positions and their progress over large areas.

2.2.2 The first stage in the provision of ATC radar equipment is normally the application of PSR as an integral part of ATC for those areas where traffic density and/or complexity create control problems. Approach control units are often the first candidates for such equipment.

2.2.3 The requirements for both terminal and en-route radar may be met by one single type of radar equipment. However, for technical reasons inherent in the principles upon which primary radar is based, a single radar for both purposes will inevitably result in the need for compromises with regard to coverage, resolution and/or rate of renewal of position information desired by the two users. For further information on the application of radar, see 2.4.1.

2.2.4 PSR facilities can be complemented by very high frequency (VHF) direction-finding equipment which is installed and operated in conjunction with the surveillance radar and which will facilitate the identification of individual aircraft on the display. Where VHF direction-finding equipment is installed as a complement to primary surveillance radar used for APP, it should preferably be located on the extended centre line of the instrument runway.

2.2.5 There are a number of important limitations to the use of PSR. The more important of these limitations are outlined below:

- a) primary radar echoes often need reinforcement due to atmospheric and technical reasons;
- b) initial radar identification of individual aircraft is often difficult both for the controller and the pilot;
- c) to maintain continuous radar identification of specific aircraft is often difficult for the controller;

- d) transfer of radar control from one controller to another and from one ATC unit to another is often not as simple and positive as would be desirable;
- e) the control display sometimes depicts an excessive amount of unwanted radar echoes because primary radar acquires returns from all reflecting objects within its range.

2.3 SECONDARY SURVEILLANCE RADAR

2.3.1 General

2.3.1.1 To overcome the limitations related to primary surveillance radar and to obtain other improvements, secondary surveillance radar (SSR) was developed.

2.3.1.2 SSR differs from primary radar in that it operates in a request-reply mode whereby the ground equipment sends out a signal which, in turn, triggers a reply signal transmitted from the aircraft transponder, rather than relying on reflected signal returns from the aircraft. This basic difference offers several advantages to both controllers and pilots using SSR. These advantages are outlined below:

- a) normally, aircraft can be detected at greater range regardless of the size of the aircraft or the reflecting area it presents;
- b) SSR is not subject to the same degree of reflections from terrain and precipitation as PSR, since different frequencies are used for the interrogation and the reply signals; thus transponder-equipped aircraft can be tracked through radar echoes of precipitation and terrain produced by primary radar;
- c) aircraft can be identified rapidly, with a minimum of radiotelephony (RTF) transmissions, since identification is established through the use of a discrete transponder code for each aircraft rather than by means of position reports or by aircraft manoeuvres; and
- d) an established SSR system provides pilots with the capability of indicating special flight situations. For this purpose, the four-digit codes 7500, 7600 and 7700 have been reserved internationally to indicate: unlawful interference; communication failure; and an aircraft emergency, respectively. Ground display equipment can be arranged so that an alarm system is automatically activated on reception of a reply on any of these codes.

2.3.2 The interrogator/transponder system

2.3.2.1 In addition to providing aircraft position information by means of interrogating equipment on the ground and transponder equipment in the aircraft, SSR provides a limited data link for transmission of information from the air to the ground, utilizing an encoder in the aircraft and a decoder on the ground. The ground-to-air interrogation process is known as the Mode and the air-to-ground reply process as the Code.

2.3.2.2 The interrogator is a transmitter/receiver which transmits groups of pulses on a frequency of 1 030 MHz using a directional rotating antenna which serves for both transmit and receive channels. This interrogator antenna is normally mounted on top of the associated primary radar antenna, although it can be located on a separate rotator in close proximity to the primary radar and with a device to make it rotate in synchronism with the primary radar antenna. The interrogation transmissions, in effect, request all airborne transponders on the mode being used to reply with the code which is set in the transponder.

2.3.2.3 The airborne transponder is a receiver/transmitter which, upon receipt of an interrogation signal from the ground, automatically replies by transmitting a coded reply on 1 090 MHz. It replies, however, only to interrogations received on the mode to which the transponder is set to respond. This reply is received by the ground receiver, processed, decoded and presented to the controller on his control display.

2.3.2.4 The control display shows position information of the same kind as that provided by primary radar but supplemented by additional information provided by the code used by the aircraft concerned. Due to the fact that the frequencies used for interrogation and reply are different, returns from terrain and precipitation do not appear on the display as they do with primary radar.

2.3.2.5 The aircraft transponder control unit incorporates controls which enable the pilot to select, according to established procedures or on request from ATC, the interrogation mode to which his transponder will reply and the code it will transmit in reply.

2.3.3 Modes

The term "mode" is used to describe the type of ground transmission or "interrogation", which is used and which is composed of pairs of pulse signals. In order to differentiate between ground interrogations for different purposes, the spacing or time interval between these pulse pairs is

varied. For civil aviation purposes, ICAO has designated four, differently spaced, pairs of interrogator pulses known as Modes A, B, C and D. The basic ATC mode is known as Mode A. This civil ATC mode has a military equivalent known as Mode 3 so that military aircraft may avail themselves of civil SSR services when required. As a consequence, the basic ATC mode is commonly referred to as Mode 3/A. Mode C is used to automatically obtain pressure-altitude information from the aircraft. With appropriate processing equipment on the ground flight level/altitude information can then be displayed in numeric form adjacent to the aircraft blip on the radar display. Currently both Modes B and D are reserved for future international use with the stipulation that, if future expansion requires the use of an additional mode, Mode D will be used ahead of Mode B.

2.3.4 Codes

2.3.4.1 Codes are aircraft transponder replies to the ground interrogators. Each code consists of a pair of framing pulses known as the bracket. Contained within this bracket of framing pulses are a series of information pulses. The presence or absence of these information pulses in 12 possible positions within the bracket is determined by the code selector in the aircraft transponder. The possibility to interchange these 12 pulse positions makes it possible to use 4 096 different codes.

2.3.4.2 When activated by the pilot, the transponder will, in addition to the normal reply pulse train, transmit an additional pulse after the last framing pulse. This additional pulse, known as the special position identification (SPI) pulse, serves for special identification purposes and is transmitted for approximately 15 s after the pilot has pushed the control button.

2.3.4.3 A high percentage of aircraft are now equipped with transponders. The number of transponder-equipped aircraft varies, however, in different parts of the world, a fact that should be taken into account in the SSR implementation process. A number of transponder-equipped aircraft are equipped with SSR transponders which have only a 64-code capability (most aircraft have a 4 096-code capability). Aircraft which have a 64-code capability can transpond only the first two digits of a four-digit code whilst aircraft with a 4 096-code capability can transpond any of the four-digit codes that may be assigned. Using the list of codes below, it may be seen that an aircraft with a two-digit code capability can select and use Codes 00, 01, 02, 03, 04, 05, 06, 07, 10, 11, 12, 13, 14, 15, 16, 17, 20 and so forth through Code 77 for a total of 64 codes. Similarly, an aircraft with a four-digit code capability can select and

use Codes 0000, 0001, 0002, 0003, 0004, 0005, 0006, 0007, 0010, 0011, 0012, and so forth through Code 0077 for a total of 64 codes in the sub-block 0000 — 0077. Sub-block 0100 — 0177 similarly contains 64 codes, because there are a total of 512 codes in that code block. Since each of the eight four-digit code blocks contain 512 codes, the total of 4 096 codes is obtained.

CODE BLOCKS

64 codes	4 096 codes
00 — 07	0000 — 0777
10 — 17	1000 — 1777
20 — 27	2000 — 2777
30 — 37	3000 — 3777
40 — 47	4000 — 4777
50 — 57	5000 — 5777
60 — 67	6000 — 6777
70 — 77	7000 — 7777

2.3.5 Limitations

As is the case with primary radar, some limitations also affect the use of SSR. For instance, SSR does not show areas of severe weather. In addition, reflections may occur and result in false positional information, or codes may be garbled when two transponding aircraft fly in close lateral proximity to each other, resulting in false code information. In areas where many SSR ground stations operate in relative proximity to each other, over-interrogation may occur.

2.3.6 Allocation and use

2.3.6.1 Administrative principles

When using SSR, the specific codes to be applied by ATS should be agreed between the administrations concerned, taking into account other users of the system (see Annex 10, Volume I, Part I, 2.5.4.1.1). Once specific codes have been agreed upon, the appropriate ATS authority shall establish procedures for the allotment of SSR codes in conformity with regional air navigation agreement. The specific codes to be used should be established on a regional basis.

2.3.6.2 Operational considerations

2.3.6.2.1 International standardization of the allocation and use of SSR codes should be sought so that the workload on both pilots and controllers and the need for voice communications are kept to an absolute minimum and the required procedural arrangements are kept as

simple as possible. Care should also be taken to ensure that the use of automation in ATC does not result in otherwise unnecessary additional requirements.

2.3.6.2.2 It should not be necessary for controllers to rely on SSR derived information in order to establish a relationship between aircraft positions and divisions of the airspace. There should, therefore, be no systematic requirement for a change of code to indicate that an aircraft is crossing the boundary of the area of responsibility of a controller or of an ATC unit.

2.3.6.2.3 Allocation of SSR codes should, in due course, create a situation in which the largest possible number of aircraft would be assigned only one code, which would be retained for the duration of their flights, irrespective of the number of control areas traversed or the number of positions involved with controlling the aircraft, except in those cases where a code change is required to cater for essential needs of ATC which cannot be covered by other means.

2.3.6.2.4 When SSR is still being used in the two-digit code configuration, and when it has been found that a code change is inevitable, such a change should, whenever possible, be so arranged that only one of the two digits composing the code is required to be changed and this change should be to the next adjacent digit. This consideration is particularly important during the arrival and departure phases of flights when the cockpit workload is highest. The application of this principle appears more easy to apply in these cases than for the en-route sections of the ATC system.

2.3.6.3 Technical considerations

Development of plans for operational code employment should take account of, but not be limited by, the technical principles in a) and b) below. These technical principles are presented to help avoid code garbling in situations where aircraft are within a slant range of approximately 3.7 km (2 NM) of one another, even though aircraft within this proximity present only a small probability of garbling. It is emphasized that the probability of garbling is very small and can be further decreased by appropriate precautions in decoder design. In some areas the principles outlined may only be a guide to assignment, especially when all the available codes are required.

- a) Whenever possible, the allotment of codes should be done so that the codes selected are least likely to generate interference when used simultaneously. Codes having the smallest number of pulses are most likely to meet this requirement.

b) Codes assigned to aircraft operating in the same area should, whenever possible, be as dissimilar as possible in their composition in order to reduce the possibility of associating an aircraft with the incorrect code.

Note.— *Basic approaches to the technical decoding and display of SSR data are outlined in Annex 10, Volume I, Part I, Attachment B, Section 5.*

2.3.6.4 *Functional codes*

2.3.6.4.1 In general, the allotment of a code for a specific function should preclude the use of this code for any other function within the area of coverage of the same SSR.

2.3.6.4.2 In areas where both the four-digit code configuration and the two-digit configuration must be used simultaneously, the first two digits of the four-figure group, used to designate one of the 4 096 codes, should be assigned and used in the same way as the two digits used to designate one of the 64 codes.

2.3.6.4.3 The use of Mode C code 2000 is only useful in areas where the cover of secondary radar extends appreciably beyond that area where SSR is used for ATC purposes by the ATC unit concerned. In such cases, the setting of this code by pilots will make it possible for controllers to have a timely indication of the presence of SSR equipped aircraft in their area of radar coverage but still outside their area of responsibility for control. Thus they can better anticipate future traffic situations.

2.3.6.5 *Individual identity codes*

2.3.6.5.1 Where there is a need for individual identification of aircraft and ground equipment permits its employment, each aircraft should be assigned a different code. However, the full use of this procedure requires the availability of auto-active decoding and labelled display facilities.

2.3.6.5.2 It is essential that the procedures used for the assignment of individual identity codes are compatible with any other code assignment procedure which may be used in immediately adjacent areas.

2.3.6.5.3 In addition, the method of assignment of individual identity codes, used by any one State, should ensure continued compatibility with the code assignment methods used by other States not equipped with similar advanced ground decoding and display systems, at least within a reasonable distance from the border area between the States concerned.

2.3.6.6 *The effects of SSR on air-ground communications*

2.3.6.6.1 There are indications that the use of SSR will permit a considerable reduction in the need for air-ground communications. This applies particularly when SSR is used in the four-digit code configuration where an individual identity code is assigned to each aircraft and when Mode C derived information is used for direct presentation of level information onto the radar display of the controller.

2.3.6.6.2 In the latter case, the continuous availability of information on the identity of an aircraft, its position and flight level, should appreciably assist in the application of control systems where air-ground communications are only required when changes from the current flight plan are requested or made necessary by the traffic situation ("silent control" concept).

2.3.6.6.3 States should therefore ensure that, as the use of SSR progresses, both as far as coverage and capability are concerned, the requirements for air-ground communications are kept under close review, with the idea that these communications may be reduced whenever it appears warranted in the light of practical operating experience.

2.3.6.7 *Accuracy of SSR Mode C data*

2.3.6.7.1 The use of SSR Mode C data must take account of the following errors affecting accuracy:

- a) correspondence error, reflecting discrepancies between level information used and the level information encoded for automatic transmission. The maximum value of this error has been accepted to be ± 38 m (125 ft) (95 per cent probability) (cf. ICAO Annex 10, Volume I, Part I, 3.8.7.12.2.5);
- b) flight technical error, reflecting inevitable deviations by aircraft from intended levels as a reaction to flight control operations, turbulence, etc. This error, when related to manually flown aircraft, tends to be larger than that for aircraft controlled by automatic pilots. The maximum value of this error used so far, based on a 95 per cent probability, is ± 60 m (200 ft) (cf. *Report of COM/OPS Divisional Meeting (1966)*, Item 9, page 9-35, 4.2). However, it should be noted that a number of factors contributing to this value have been improved since.

2.3.6.7.2 The mathematical combination of the non-related errors in a) and b) above results in a value of ± 72 m (235 ft) (based on a 95 per cent probability) and

it is therefore believed that a value of ± 90 m (300 ft) constitutes a valid decision criterion to be applied in practice when:

- a) verifying the accuracy of SSR Mode C data;
- b) determining the occupancy of levels.

2.3.6.8 An important technological development in the area of SSR systems is the monopulse technique and an improved SSR Mode S. These applications of SSR are discussed in Part II, Section 3, Chapter 3 — Use of Automation.

2.4 PRECISION APPROACH RADAR

2.4.1 Precision approach radar (PAR) is designed to enable a properly qualified air traffic controller to provide instructions to an aircraft to enable the pilot to maintain an exactly aligned descent on final approach to a runway. Since aircraft utilizing this facility are operating near critical speed and reduced terrain clearance, it is therefore imperative that radar provide exact guidance information in both the vertical and horizontal plane. To accomplish this, the radar scans a sector 20° in azimuth (horizontal) and 7° in elevation (vertical) to a distance of approximately 20 km (10 NM). Anywhere within this sector the radar controller can furnish the required azimuth and elevation guidance information to the pilot for manoeuvring of his aircraft. Basically the PAR serves the same purpose as an instrument landing system (ILS), except that the guidance information is presented to the pilot through oral instead of visual means. At some locations PAR is used as an additional safety factor to monitor aircraft making ILS approaches. The use of PAR, however, is diminishing throughout the world as an alternative or complement to the ILS mainly because of its limited capacity, the continuous proficiency training requirement for controllers and the resulting, comparatively high, operating costs.

2.4.2 Annex 10 recommends the use of PAR as an alternative to ILS where the latter facility is required but technically impracticable and as a supplement to ILS under specific circumstances.

2.5 PERFORMANCE OF RADAR EQUIPMENT

2.5.1 In view of the fact that the safety and efficiency of radar services depend to a large extent on the reliability and

the coverage of the radar equipment in its day-by-day performance, and the accuracy with which the data displays are set up, the performance of the radar must be carefully monitored to ensure that:

- a) the quality of the information provided is checked and found satisfactory prior to the use of the equipment for the provision of ATS;
- b) adequate technical instructions are issued in respect to the use of radar, detailing the area within which radar service may normally be provided, and specifying the radar display set-up procedures and accuracy and performance checks which must be carried out by radar controllers prior to and during use of the equipment.

2.5.2 The following table provides guidance for the recording of signal strength:

Table 1.— Recording signal strengths

Strength	Description of radar blip	Usability
0 — Nil	No visible blip	None
1 — Poor	Barely visible blip	Unreliable
2 — Acceptable	Discernible blip	
3 — } 4 — } Good	No persistence Blip discernible during one complete revolution	Normal
	Discernible blip with positive trail	

2.6 RADAR GLIDE PATHS

2.6.1 Establishment of glide path

Where a runway is served by both an ILS and radar, it is desirable, from an operational point of view, that the radar glide path be so established as to pass through the ILS reference datum and that the elevation angles of both the nominal ILS and radar glide paths be the same. Particular attention should also be given to the need for the glide path to provide for safe obstacle clearance at all points.

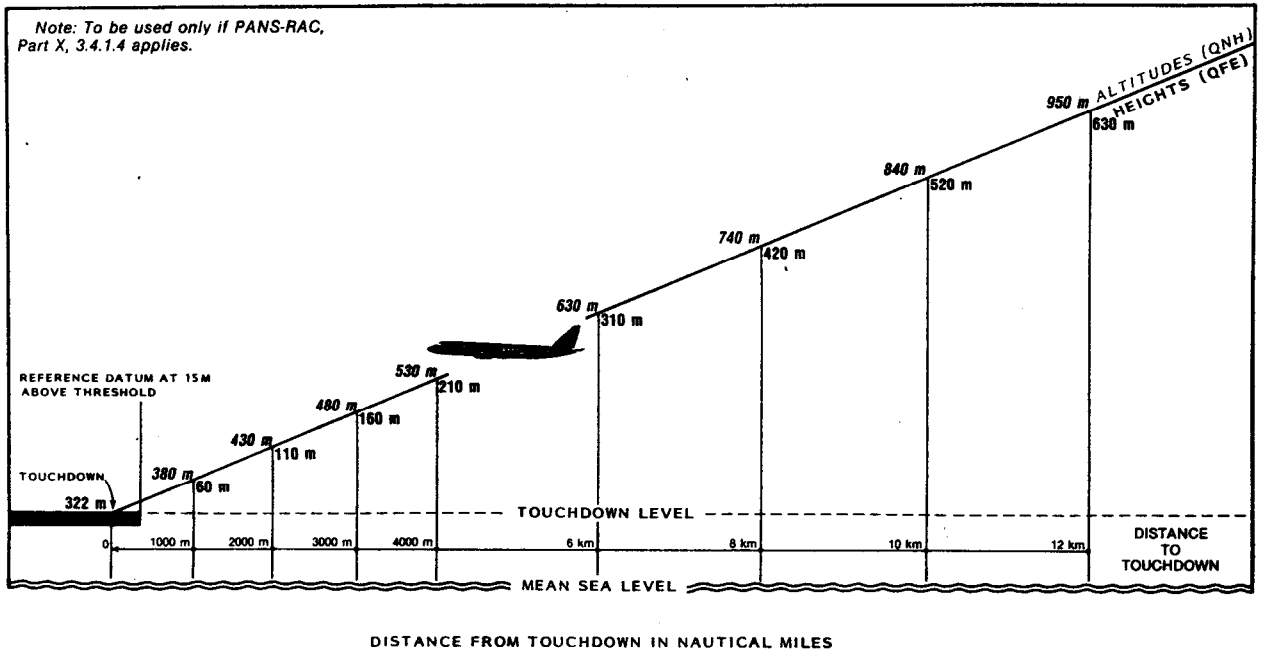

Figure 2 a).— Typical pre-computed levels for a 3-degree glide path — (SI units)

2.6.2 Computation of levels

2.6.2.1 The levels through which an aircraft should pass at various distances from touchdown, while making a surveillance approach, can be computed as follows:

- multiply the distance to touchdown in kilometres by the angle of the glide path in degrees and then by 17.5* to obtain a height in metres or multiply the distance to touchdown in nautical miles by the angle of the glide path in degrees and then by 106** to obtain a height in feet above touchdown elevation;
- add the touchdown elevation in metres or feet to obtain altitude;
- round off the results from a) and b) to the nearest 10 m or 100 ft as appropriate, except when level information is given at distances closer than 4 km (2 NM) from touchdown, where they should be rounded up to the next whole 10 m or 10 ft increment as appropriate.

2.6.2.2 An example of the application of the computation of levels is provided in Figures 2 a) and 2 b).

* $0.0175 \times 1\,000 \text{ m}$.

** $0.0175 \times 6\,080 \text{ ft}$.

*** Rate of descent in metres per second = ground speed in kilometres per hour \times angle in radians $\times \frac{1\,000}{3\,600}$.

**** Rate of descent in feet per minute = ground speed in knots \times angle in radians $\times \frac{6\,080}{60}$.

2.6.3 Rates of descent

2.6.3.1 The approximate rate of descent for a given ground speed on a final approach can be determined as follows:

- using the surface wind, subtract the headwind component, or add the tailwind component, from the true airspeed to obtain the approximate ground speed in kilometres per hour or knots; and
- divide the ground speed in kilometres per hour resulting from a) above by 100, 85 or 70 for a 2 degree, 2½ degree or 3 degree glide path respectively to obtain the approximate rate of descent in metres per second*** or multiply the ground speed resulting from a) above by 3, 4 or 5 for a 2 degree, 2½ degree or 3 degree glide path respectively to obtain the approximate rate of descent in feet per minute****.

2.6.3.2 A tabulation as shown in Table 2 a) and b), computed in accordance with the method in b), will provide a convenient reference for the radar controller.

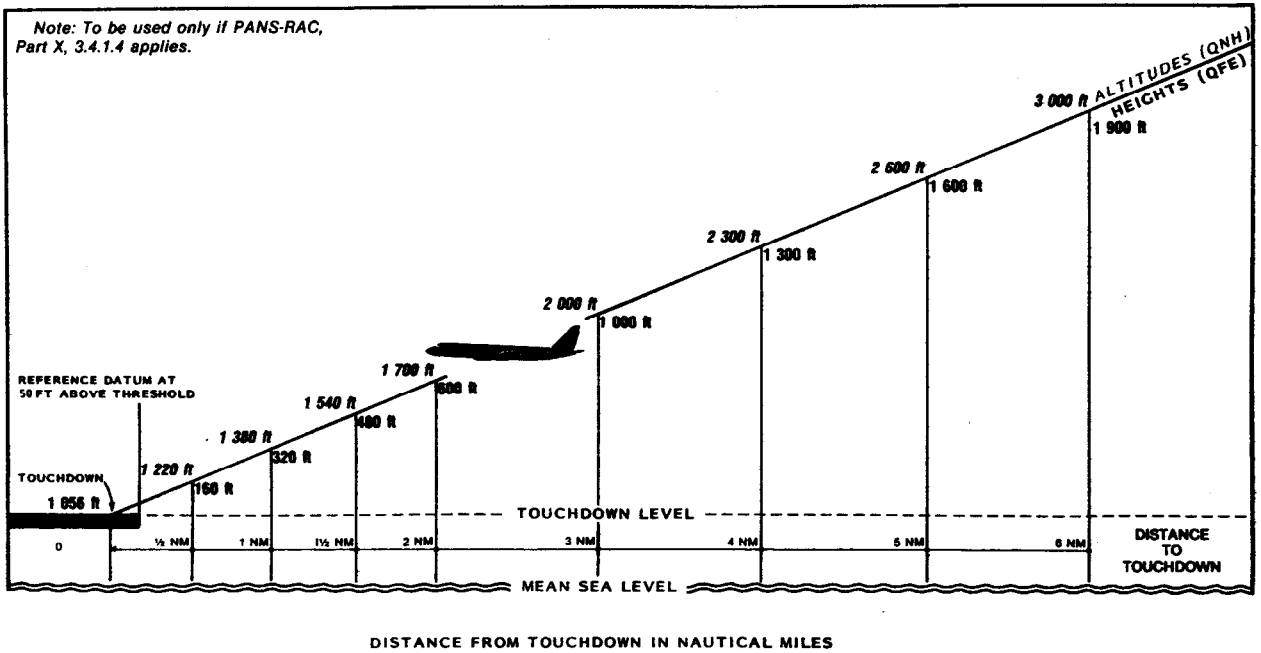

Figure 2 b).— Typical pre-computed levels for a 3-degree glide path — (non-SI alternative units)

Table 2 a).— Typical rates of descent for a 3-degree glide path — (SI units)

Ground speed kt	Rate of descent m/s	Ground speed kt	Rate of descent m/s
70	1.00	210	3.00
58	1.25	228	3.25
105	1.50	245	3.50
123	1.75	263	3.75
140	2.00	280	4.00
158	2.25	298	4.25
175	2.50	315	4.50
193	2.75	etc.	...

Table 2 b).— Typical rates of descent for a 3-degree glide path — (non SI alternative units)

Ground speed kt	Rate of descent ft/min	Ground speed kt	Rate of descent ft/min
40	200	120	600
50	250	130	650
60	300	140	700
70	350	150	750
80	400	160	800
90	450	170	850
100	500	180	900
110	550	etc.	...

2.7 INTEGRATION OF RADAR AND NON-RADAR SERVICES

2.7.1 When radar is used in support of any one or all of the ATS, it should be operated as an integral component of the relevant ACC, approach control (APP) office, aerodrome control tower (TWR) or flight information centre (FIC).

2.7.2 In assigning the duties and responsibilities for the use of the radar-derived information in ATS, the chief of the ATS unit in which radar is used should ensure that:

- a radar controller is not required to perform additional duties that are not directly related to the exercise of radar service;
- the requisite radar services are provided to the maximum extent compatible with workload limitations, communications capacity, equipment capabilities and the capability of the radar controllers to revert to procedural separation in the event of radar equipment failure or any other emergency;

Note.— The additional action required in identifying aircraft, providing specific navigational guidance, being alert to unidentified traffic and providing aircraft with

services other than those directly related to the control of air traffic increases, among other things, controller workload and communications. Primary radar equipment is sometimes affected by atmospheric conditions which may reduce its effectiveness and restrict its use. On occasion, the amount of interference created by precipitation may be such that radar blips cannot be tracked through the resulting clutter on the radar display.

- c) maximum use is made of radar maps which readily show ATS routes, reporting points, limits of controlled airspace and airspace restrictions, prominent obstructions including terrain, noise abatement routes, etc., in the radar controllers' area of responsibility.

2.8 INTEGRATION OF SSR INTO THE ATC RADAR SYSTEM

2.8.1 General

2.8.1.1 In States where SSR has been brought into use in the ATC radar system, the implementation process has normally been evolutionary in nature and was done so that the development and introduction of increasingly sophisticated equipment could keep pace with the increasing demands of air traffic.

2.8.1.2 Initially, the integration of SSR into the ATC radar system was an evolutionary process and started with the implementation and use of the two-digit code Mode 3/A system, followed later by the four-digit code Mode 3/A system, supplemented by Mode C interrogations with automatic pressure altitude reporting. However, in recent years, implementation has started out immediately with the installation of SSR ground equipment with a four-digit code capability. In most instances, implementation has been accomplished on a step-by-step basis whereby the use of SSR was initially limited to the different portions of the upper airspace and then expanded to cover selected portions of the lower airspace. The next major step in SSR development normally has been the introduction of automation into the affected ACCs and major terminal area ATC units. Generally speaking, the integration of SSR has been accomplished by a continuing process whereby more advanced and more sophisticated equipment, and modifications to existing equipment were brought into operation.

2.8.1.3 Considering the present state of the art, two-digit code systems should no longer be considered for use.

Therefore, whenever the use of SSR for ATS is considered by States, it should be planned, from the start, with the use of four-digit codes in Mode A and automatic pressure-altitude reporting in Mode C with automatic decoding equipment and, together with other flight data, processed and correlated by automatic equipment for alphanumeric presentation on the display of the controller. The identification of each SSR-equipped aircraft provides the air traffic controller with a traffic display permitting continuous identification and monitoring of the movement of co-operating aircraft. It is essential, however, that provisions are made to accommodate aircraft which are equipped with only a two-digit code capability, or are not equipped with SSR at all, since these aircraft are still expected to operate on a four-digit code SSR environment. A State which is only beginning to use SSR may not have the density of traffic to justify the expense involved in a full and complete SSR system as set forth above; nor may they have the level of expertise amongst ground personnel to apply the associated methods. Steps for the progressive implementation of an SSR system are described in 2.8.2.

2.8.1.4 When planning the introduction of SSR, it is essential that the procedures for the use of the appropriate equipment are clearly defined at each stage of the development in documentation addressed to pilots and controllers. Consideration should be given to the need to make SSR transponder equipment in aircraft mandatory in specific parts of the airspace. Appropriate safeguards will have to be established in the ATC procedures to ensure that information on the non-equipped aircraft is available to the controller by other means, e.g. primary radar or non-radar position reporting.

2.8.1.5 In those States where highly developed SSR systems are available and a high density of air traffic exists, ATC appears to be relying increasingly on the extensive use of automated ATC systems to ensure uninterrupted identification of individual aircraft, and the maintenance of radar/flight plan correlation.

2.8.1.6 When traffic density and ATC systems complexity justify the costs involved in producing an SSR system, a significant operational improvement can be achieved through automatic processing and display of SSR-derived data. The computer-generated symbols thus provided and associated with the radar target, can variously depict aircraft identification, type, flight level/altitude information, and if required, ground speed. These symbols can significantly reduce the problems associated with identification, tracking, flight level/altitude verification, monitoring of aircraft speed and frequency congestion and can result in appreciable reductions of the

workload associated with strip marking and controller co-ordination, including target correlation.

2.8.2 Integration process

2.8.2.1 To obtain optimum results, the following step-by-step process should be considered when planning the integration of SSR into the ATC radar system:

- a) Step One:
 - 1) co-locate SSR installations with existing primary radar installations;
 - 2) mount SSR antennas on existing primary radar antennas;
 - 3) display SSR signals on the same radar control display as primary radar signals;
 - 4) provide plan position indicator (PPI) displays, or scan converted television-type bright displays, for presentation of combined SSR/primary radar information to controllers;
 - 5) implement the four-digit code system with digitized automatic decoding, including alphanumeric presentation on the radar display of individual identity codes and Mode C information;
 - 6) publish procedures in advance of the commissioning of the SSR for its use as an integral part of the ATC radar system;
 - 7) arrange for necessary training and qualification of ATC and maintenance personnel;
- b) Step Two:
 - 1) provide advanced digitized radar remoting and display systems to enable significant expansion of SSR coverage by transferring data from remotely located SSRs into the appropriate ACCs;
 - 2) publish any necessary modification of the published procedures;
 - 3) provide for additional training and qualifications, if any, required in Step Two, for ATC and maintenance personnel.

2.8.2.2 SSR Mode C provides the capability of automatically telemetering the pressure-altitude of the aircraft to the ground for display to the controller concerned, thereby greatly enhancing the effectiveness of ATC radar. It should therefore be regarded as a communications tool which permits air traffic controllers to have a direct and continuous presentation of aircraft flight level/altitude without resorting to voice communication. The use of this feature can significantly decrease the workload of both controllers and pilots. Care must be taken, however, to cross check accuracies of Mode C derived information.

2.9 APPLICATION OF RADAR SEPARATION

2.9.1 General

2.9.1.1 Radar separation minimum is normally that which is prescribed in PANS-RAC, Part X. However, in the application of radar separation, the controller must always be alert to the need to take action on a timely basis when it appears that two aircraft may come closer together than the prescribed minimum.

2.9.1.2 Specific circumstances which may require the application of greater radar separation than the minimum normally prescribed are outlined below:

- a) Aircraft relative positions and performance limitations

The rate which relative positions of any two aircraft under radar control change, both in the horizontal and vertical plane, is an important factor in considering what radar separation may safely be applied in a given instance. The fact that aircraft operating at high speeds have only a limited ability to make rapid changes of heading, if required to do so, should also be taken into account. This fact is particularly relevant to transonic and supersonic operations where high speeds require a large amount of airspace and rapid rates of change of speed necessitate early and close attention to possible conflicts, if large or abrupt changes of heading are to be avoided.
- b) Radar technical limitations
 - 1) *Effective beam width*: since two radar blips on a raw radar display may at no time be allowed to touch, the width of a radar blip is a significant factor in separating aircraft at the same range on slightly different bearings. A wide effective beam width may therefore require an increase in the separation applied between two aircraft at substantial distances from the radar antenna. The following table provides an indication of the minimum distances between any two aircraft whose radar blips would begin to touch:

Table 3.— Minimum distances between two aircraft whose radar blips begin to touch

Effective beam width (degrees)	Beam width at distance from radar antenna		
	30 km (15 NM)	120 km (60 NM)	240 km (120 NM)
1°	0.5 km (0.25 NM)	2 km (1 NM)	4 km (2 NM)
3°	1.5 km (0.75 NM)	6 km (3 NM)	12 km (6 NM)
5°	2.5 km (1.25 NM)	10 km (5 NM)	20 km (10 NM)

- 2) *Pulse length*: The pulse length of a surveillance radar affects the thickness of the radar blip on a raw radar display and therefore controls the possibility of distinguishing two aircraft on the same bearing at slightly different distances from the radar antenna.
- 3) *Rate of scan*: The rate of scan, which determines the frequency with which the radar controller obtains a renewal of position information on aircraft, is significant in that it determines how far each aircraft will move between successive indications of the radar blip (see a) above). In effect, the lower the rate of scan, the greater the displacement of aircraft and also the relative potential position between any two aircraft. Such a condition may, in some cases, make it necessary to apply a greater separation. The following table indicates how far an aircraft, flying at 890 km/h (480 kt), can be expected to have moved between successive indications of its position on the display with varying rates of scan:

Table 4.— Expected movement between successive scans for aircraft flying 890 km/h (480 kt)

Rate of scan/ rotations per minute (rpm)	Distance aircraft moves
16 rpm	0.9 km (0.5 NM)
8 rpm	1.9 km (1.0 NM)
4 rpm	3.7 km (2.0 NM)

The table shows that with a rate of scan of 4 rpm, the radar blips of two jet aircraft approaching head on and observed on one antenna sweep to be 14.8 km (8 NM) apart, will be seen 7.4 km (4 NM) apart on the next sweep 15 seconds later and will merge on the third sweep another 15 seconds later. A supersonic aircraft, flying at 2 220 km/h (1 200 kt), would move 9.4 km (5 NM) between each successive scan when the rate of scan is 4 rpm, and thus the radar blips of two supersonic aircraft approaching head on and observed to be 18.5 km (10 NM) apart will have merged on the next scan.

- 4) *Persistence of the radar display*: The persistence factor (after-glow) of a radar display will provide a ready indication to the radar controller of the tracks made good by each aircraft shown on the display. This indication is commonly called the "trail". The longer this after-glow the longer will be the trail.
- 5) *Radar coverage — day-to-day performance*: Provisions for the required performance checks of a particular radar equipment are given in PANS-RAC, Part X, 1.2.1. The design of the radar equipment

itself determines the normal radar coverage which can effectively be used for the exercise of radar control. However, the actual coverage may differ from time to time due to a number of factors including various atmospheric and weather effects, variations in tuning of the radar by the technicians, and the way in which the radar controller utilizes the controls of his radar display. The result of day-to-day radar performance is that, on occasion, targets normally expected to be within radar coverage may be visible intermittently only, or may be severely attenuated or not be visible at all.

- c) Radar controller limitations
 - 1) *Radar controller workload*: The number of aircraft which can safely be provided with radar separation at the same time is limited and varies with individual controller proficiency. A radar controller should therefore take due account of the number of aircraft within his sector of responsibility for which he is providing radar control, his own limitations and the geographical extent of his area of responsibility (i.e. the possible requirement to provide radar separation between aircraft in two or more separate traffic complexes which are some distance apart).
 - 2) *Communications congestion*: Because the relative positions of aircraft may change rapidly, it is implicit in applying radar separation that a radar controller should be able to communicate promptly with any aircraft under his control. If the communications congestion is such that this cannot be assured, then the radar controller should apply greater radar separation or, when this is not practicable, terminate radar control. In this respect it should be noted that of all the factors affecting the safe application of radar separation, communications congestion is probably the most important and one on which the radar controller may have little influence. Congestion is also difficult to predict since, with rapidly changing traffic situations, the communications load can build up to saturation within minutes.

2.9.2 Reduction of minima

2.9.2.1 Attention is drawn to certain principles regarding the factors which should be taken into account in determining reduced separation minima. These principles are contained in Part II, Section 2, Chapter 1, 1.4.

2.9.2.2 Where distance from the radar antenna is used as a criterion in expressing reduced separation minima, this reduction should be limited to equipment used for approach or departure purposes.

2.9.2.3 In the more congested terminal areas where manoeuvring space is at a premium and where speed adjustment procedures are applied to departing and arriving flights, lower separation minima may be applied than could otherwise be possible.

2.9.3 Use of SSR data

2.9.3.1 The PANS-RAC, Part X, requires that the use of radar in ATS be limited to specified areas of radar coverage and be subject to such other limitations as are specified by the appropriate ATS authority. It further requires that adequate information is published in aeronautical information publications on the operating methods used as well as on operating practices and/or equipment limitations having direct effects on the operation of the ATS. Additionally, it notes that, in order to assist pilots in the operation of their SSR transponders and in the setting of the correct code, States should provide information on the area or areas where SSR is in use and on the codes expected to be used. Finally, the PANS-RAC also requires that SSR information alone, without primary radar information, should not normally be used for the provision of separation to aircraft, except as specified by regional air navigation agreements.

2.9.3.2 The use of SSR data in association with primary surveillance radar should be governed by the provision of the requirements specified in 2.9.3.3 below and described in appropriate regional air navigation agreements.

2.9.3.3 During certain conditions the primary radar echoes from some types of aircraft are not, or are not continuously, presented on the radar display of the controller owing to the reflecting characteristics of such aircraft. In addition, precipitation and terrain sometimes produce such a large number of echoes on the display that it becomes difficult to properly see aircraft echoes. In order to overcome these known deficiencies of primary radar, SSR responses may be used for the separation of transponder-equipped aircraft within the coverage of the associated primary radar from other known aircraft not using SSR, but displayed clearly on the primary radar display, provided that the SSR response from any aircraft (not necessarily the one being provided separation) coincides with the primary radar echo of the same aircraft.

2.9.3.4 SSR information, without primary surveillance radar information, should be employed for the provision of separation between aircraft only after compliance with several very stringent requirements; and then only as specified by regional air navigation agreements.

2.9.3.5 Regional air navigation agreements providing separation between aircraft with the use of SSR alone (including those cases where either primary surveillance radar is not available or in areas outside the coverage of existing primary radar) should cover the following points:

- a) the affected airspace should be described in regard to its lateral and vertical dimensions;
- b) the affected airspace should be designated as airspace in which only controlled flights may operate;
- c) aircraft to be provided separation from each other by means of SSR should be equipped with a functioning transponder(s) operating on the appropriate mode(s) and code(s);
- d) aircraft should obtain an appropriate ATC clearance before penetrating the affected airspace;
- e) reliable SSR coverage should exist within the affected airspace;
- f) SSR accuracy in the affected airspace should be verifiable by means of appropriate monitor equipment;
- g) non-radar separation should be applied between aircraft with functioning transponders and other aircraft, and between all non-transponding aircraft within the affected airspace;
- h) the density of air traffic, the navigational environment and the controller proficiency should be such that non-SSR separation may be safely reverted to without delay in case of SSR failure or malfunction;
- i) control of all aircraft operating within the affected airspace should be exercised by a single ATC unit, unless adequate means of co-ordination exist between all ATC units concerned.

2.9.3.6 Irrespective of 2.9.3.4 and 2.9.3.5 above, SSR data without primary surveillance radar information may be used:

- a) to provide identification of aircraft;
- b) to provide aircraft position where non-radar separation is applied.

2.10 SEPARATION BASED ON COMPUTER-PROCESSED RADAR DATA

2.10.1 Technical considerations

2.10.1.1 Plot extraction

2.10.1.1.1 The common basic position data source used by all digital radar data processing systems is the plot extractor. The function of this equipment, which is

normally installed at the radar site, is to convert into digital form the analogue range and bearing information on targets located by the radar sensor or sensors for transmission to the radar data processing and display computer systems at the ATS unit served. The digital position data are held in buffer storage before their onward transmission via narrow band data link. This situation results in random transmission delays of up to one radar rotation period. Plot positions received by the radar data processing computer are subsequently converted into digital X and Y system position co-ordinates before further processing is carried out. The ability of the plot extractor to discriminate between targets from aircraft flying in close proximity to each other is dependent on the resolution capability of the radar sensor itself. The geographical accuracy of plot positions provided is also dependent, in the first instance, on the accuracy of the radar sensor, as well as on the efficiency of the plot extractor used.

2.10.1.1.2 The plot extractor can determine the slant range of aircraft targets with greater precision than can a controller using a raw video radar data display. Since controllers are, for range separation purposes, concerned only with the accurate determination of distance between targets on the same bearing within a relatively narrow height band, slant range information is satisfactory for the application of range separation (where the data presented are derived from sensors at the same radar site). The range resolution capability of all ATC radar sensors is considerably better than 5 NM and is constant for targets at all ranges from the radar head. The plot extraction process should in no way degrade the sensor's range resolution capability.

2.10.1.1.3 The azimuth resolution capability of any radar sensor is primarily a function of its beam width. With two aircraft at the same general range, but on slightly different bearings, the geographical distance required between the aircraft to enable the sensor to recognize them as separate targets therefore depends on, and increases with, beam width and range from the radar head. With wider beam width radars especially, the azimuth resolution capability increases steadily beyond a certain range from the radar head. On raw video radar displays, a controller can only discriminate between two aircraft on different bearings at about the same range if the radar blips of the target aircraft do not overlap, because the azimuth resolution capability on raw video displays is worse than that of the radar sensor itself due to the effect of CRT spot size on both width and depth of radar blips. The requirement to ensure that blips do not overlap, therefore, generally results in an increase of the azimuth separation minimum which is proportional to the increase in range of the targets concerned.

2.10.1.1.4 The plot extractor can discriminate between targets at the same general range on different bearings more readily than can the controller when using a raw video radar display; but only within the limits of the azimuth resolution capability of the radar sensor. Where two target aircraft are on slightly different bearings at very slightly different ranges (i.e. so that on a raw video radar display the blips would overlap because of the depth of the radar blip), the better range resolution capability of the plot extractor will frequently enable it to resolve the targets as separate aircraft. Nevertheless, the azimuth separation minimum, used with digital radar positional data, must be related, with increasing range, to the resolution capability of the radar sensor.

2.10.1.1.5 The accuracy of the bearing position data, provided by the radar sensor, is angular in nature and is dependent again in geographical terms on the characteristics of the sensing equipment and the range of targets from the radar head. On raw video radar displays the controller has to determine the azimuth position of an aircraft by visual assessment of the mid-position of the arc of the displayed radar blip. The wider the beam width of the radar sensor and the farther the target from the radar head, the more difficult it is to make an accurate assessment of the bearing. The techniques used for target bearing determination by plot extractors vary in detail with different equipment, but all of them measure about the mid-points between the start and stop bearing points at which the radar sensor receives returns from a target as it sweeps through, utilizing a strike counting system. With primary radar plot extractors, an adjustable threshold noise value is set and only those signals which are received with a strength which is greater than the noise value are recorded as "hits". Due to variations in radiated antenna pattern, inter-pulse target reflectivity variations and attenuation with range, the number and pattern of recorded "hits" varies from sweep to sweep and is random in nature. This can result in angular inaccuracies in plot extractor bearing measurements when compared with the true bearing of the order of 10 per cent of the sensor beam width. With SSR plot extractors, all responses received by the sensor are recorded as "hits". Loss of the "hits" with SSR can still occur, however, due to the inherent limitations of the SSR system, resulting in asymmetry of the "hit" pattern and consequential bearing measurement inaccuracies. These inaccuracies have to be taken into account in determining the minimum radar azimuth separation which needs to be applied.

2.10.1.1.6 Where position data, received by both primary radar and SSR sensors at the same radar site, are processed by the plot extractor, both plots are transmitted to the radar processing computer where they are compared. If the

plots can be correlated as pertaining to the same aircraft, a joint primary radar/SSR plot is formed.

2.10.1.1.7 Due to siting and radiation pattern characteristics, gaps occur in the coverage of radar sensors themselves and result in "missed plots" while aircraft are in areas of non-coverage (in the same way as, on raw video radar displays, blips would disappear in the areas concerned). However, if on any sweep, insufficient strikes or responses are received by the plot extractor to enable it to validate a target as an aircraft, a "missed-plot" situation arises and no plot information is transmitted. According to the variable parameters set in the plot extractor, this condition can cause no plot information being provided on a target which, on a raw video radar display, would still be seen as a weak radar blip. In practice, "missed-plots" of this latter nature frequently occur for two or more consecutive sweeps of the aerial head.

2.10.1.1.8 Again due primarily to siting problems, reflection of the radiated signals from objects adjacent to the radar aerial results in the recording and transmission of spurious, plot extracted, position data leading to the display of additional false or reflected targets. These false targets are usually shown in excess of the actual range of the target aircraft concerned and on grossly wrong bearings. Particularly with the use of SSR and digital data display systems, where the target positions are usually tagged with identification and height labels, these reflections are a source of great concern to controllers, especially when the false position data appear on a display in the area of responsibility of another controller.

2.10.1.2 *Computer tracking*

By the application of computer tracking programmes, plot messages received from the plot extractor on a particular target aircraft can be correlated from sweep to sweep and a radar track established by the radar data processing system. Once a radar track has been established (normally not until at least three consecutive plot positions have been correlated), the computer compares the predicted position (determined from past history) with each new plot position received and interpolates the most likely real target position. This condition has the effect of damping down inter-sweep azimuth plot errors before they are displayed to the controller. This capability is known as "track smoothing". The system delays somewhat the presentation of updated position information to the controller. The computer tends to resist accepting track changes and data displayed lags marginally behind the actual turn. A further feature of computer tracking programmes is that, in the event of a missed plot or plots, the predicted position of target, as determined from past

history, can still be shown to the controller to preserve continuity of positional data. This facility is known as track coasting and is normally only continued for about three consecutive missed plots.

2.10.1.3 *Composite radar data processing*

2.10.1.3.1 A further development in radar data processing techniques is the utilization of plot extracted positional information, derived from more than one radar site, to provide composite radar pictures of all or parts of an extended, predetermined, system area.

2.10.1.3.2 In its most complex form, primary and SSR digital radar position data, received from sensors at two or more geographically separate sites with overlapping radar coverage, are used to build up a composite radar positional data base for the whole system area. Optimum radar data sensor sources are pre-selected and alternate sources are being used, as available, to back up the preferred radar data sensor source. In this way, areas of poor coverage, or non-coverage of any one sensor, can be covered by alternate radar sensors (where available), thus reducing the incidence of missed plots and providing a more complete and reliable positional data base for the system area. Such a system must, however, provide smooth aircraft track continuity during change-over of data utilization from one sensor to another. To achieve this, very precise geographical position data are required from each sensor and slant range compensation processing, utilizing target height data, is essential. The main feature of this system is that a radar controller may select for display any part of the total system area, the position data displayed being in mosaic form and showing the optimum data available from sensors covering the selected area.

2.10.1.3.3 In less complex radar data processing systems a composite radar positional data base is built up by dividing the total system area into two or more geographical divisions (dependent on the number of different radar sensor sites used) and using within each sub-area data received from only the predetermined optimum site. With this system, there is still a requirement to ensure the smooth aircraft track continuity during transition from one sensor site sub-area to another.

2.10.1.3.4 Finally in their most simple form, digital SSR positional data may be processed for superimposition on raw video primary radar displays showing data derived from a geographically separate site. The main object of this system is to provide SSR identification and height information in the most economical way to supplement basic raw video primary radar positional data, where the coverage of the primary and SSR radar sites is compatible.

Slant range compensation is generally not practicable with such systems and so accurate registration of raw video primary and digital SSR positional data can, therefore, not be achieved throughout the display area. For this reason, raw video primary radar position data only should normally be used for radar separation purposes.

2.10.2 Operational considerations

2.10.2.1 *Displays showing simple plot-extracted position data derived from a single radar site*

2.10.2.1.1 With digital data display systems, the updated position of a target aircraft is indicated by a small radar position symbol (RPS). The size of this symbol normally has no predetermined geographical value and does not change with range from the radar head or with selected display scale. Track history is provided by displaying the most recent past plot positions received from the plot extractor (normally known as “trail dots”).

2.10.2.1.2 Provided that the plot extractor can discriminate between separate aircraft targets, this system provides the controller with clearly distinguishable position symbols which do not overlap if they are 9.3 km (5 NM) apart in range or azimuth (whatever the beam width of the radar sensor or range of target from aerial head may be). A basic requirement in the use of radar separation is to ensure that aircraft in close proximity can continue to be resolved as separate targets. On raw video radar displays, this resolution is easily achieved by the controller himself by ensuring that displayed radar blip edges (particularly in azimuth) do not overlap. However, with digital displays the controller cannot see from his display when any two aircraft are getting too close to each other in azimuth to permit the plot extractor to continue to resolve the aircraft as individual plots. It is essential, therefore, to compensate for this deficiency of digital data display systems by increasing the azimuth separation minimum applied to cater for the azimuth resolution capability of the sensor used. In practical terms, this requirement is dependent primarily on the beam width of the sensor and the range of target from the aerial head. It means, in fact, that, for azimuth resolution purposes, for any radar sensor, the 9.3 km (5 NM) separation criterion applied between radar position symbol centres holds good only up to a calculable range from the radar head. Thereafter, the minimum should steadily increase with range from the radar head.

2.10.2.1.3 Where simple plot extracted radar display systems have been introduced in various parts of the world, individual States have taken action to increase the radar separation minima to be applied by radar controllers as a

means of re-providing the additional azimuth spacing, inherent in the current Annex 11 procedures for the application of radar separation in azimuth. The measures taken and criteria established vary considerably — the only common feature to most being the introduction of stepped increases in azimuth separation minima at predetermined ranges from the radar site. This method of dealing with the problem is far from ideal since, for practical implementation reasons, it is essential to reduce the number of separation changes to the absolute minimum, whereas the actual requirement is to provide a logical and progressively increasing buffer element for azimuth separation with increasing range of targets from the radar head. There are, in addition, certain application problems for controllers when two or even three different separation criteria have to be applied in different areas of the same radar display. At the very least, it is essential to provide range marking information in order to facilitate recognition of areas where different criteria are to be applied.

2.10.2.1.4 Because the use of range-stepped increases in azimuth separation criteria is unsatisfactory from both technical and operational points of view consideration should be given to alternative ways of providing increased azimuth separation with range. One method which might be employed is to rationalize geographically the size of displayed RPSs by increasing their dimensions with range from the radar head in such a way as to permit retention of the existing 9.3 km (5 NM) azimuth separation minimum for application on a symbol-edge to symbol-edge basis. The geographical area occupied by the RPS would be dependent on range and would, by itself, provide the additional separation required. This would facilitate both the application of azimuth separation by controllers and make it possible to introduce more logical small-step increases.

2.10.2.1.5 For the reasons given in 2.10.1.1.5, intersweep variations occur in the bearing element of plot-extracted position data displayed to the controller, whereby the geographical extent of the variations increases with sensor beam width and range of target from the radar head. The variations are more particularly with aircraft flying tracks which are radial in relation to the radar head, and result in displayed “track jitter” which frequently makes it difficult for controllers to accurately assess aircraft tracks and rapidly detect track changes. Because of the display system, the jitter effect is of much greater operational significance with digital radar data displays than is the case with raw video displays. On raw video displays, the jitter is masked by the size of the radar blips, their indistinct edges and the blurred appearance of the phosphor after-glow, all of which makes an apparently smooth track presentation. A very commonly applied

technique for separating passing traffic on the same or opposite direction tracks is parallel tracking, for which accurate track assessment and rapid detection of target turns is essential. The effect of “track jitter” on simple, plot-extracted digital radar data displays needs, therefore, to be taken into account in establishing radar separation minima.

2.10.2.1.6 Finally the incidence of “missed-plots”, as discussed in 2.10.1.1.7, needs to be taken into account in determining separation criteria.

2.10.2.2 *Displays showing computer tracked position data derived from a single radar site*

2.10.2.2.1 Experience by ATC in the use of computer tracked position data is at present still limited. However, as discussed in 2.10.1.2, the main advantage of computer tracked data over simple plot-extracted data is that the effects of “track jitter” are significantly reduced and the over-all accuracy of displayed azimuth positional information is improved. The actual method of displaying track information varies considerably and may be in the form of past history (trail dots), of a tail vector, proportionate in length to ground speed or of a forward (lead) vector. With straight tail or lead vectors there is no direct indication of turning targets; however, even with the use of lead vectors, which show a change of track, there is no indication of rate of turn.

2.10.2.2.2 Even though the presentation of updated position information to controllers is marginally delayed by the nature of computer-tracking programmes, it should not normally be an operationally significant factor in determining separation minima. Of more operational importance, however, is the fact that there is an inherent lag in target turn indication which needs to be taken into account.

2.10.2.2.3 A further point made in 2.10.1.2 is that the “missed-plot” situation can be alleviated in radar tracking by presenting predicted position information to the controller, to preserve track continuity. However, the extent to which track coasting position data may be used for separation purposes requires special consideration.

2.10.2.2.4 The basic requirement to ensure that azimuth separation minima are compatible with radar sensor azimuth resolution capability (2.10.2.1.2 to 2.10.2.1.4 refer) is also applicable to the use of computer-tracked position data.

2.10.2.3 *Mosaic displays showing digital position data derived from two or more geographically separate radar sensor sites*

2.10.2.3.1 Experience with the use of mosaic displays, showing data provided by complex radar data processing systems of the type described in 2.10.1.3.2, is limited. With such displays, the significant difference is that the controller does not know from which radar site the plots, used for radar tracking, are derived. Therefore, he does not know whether he is applying range or azimuth separation between any two targets; nor does he know the range of the targets from the radar sensor providing the plot information. It would also be pointless to attempt to indicate on the display the data source of position information since it would be impractical for the controller to attempt to use this information for separation criteria application purposes. One radar separation minimum must therefore be specified for application on a uniform basis throughout the system area. Such minimum must be based on “worst case” azimuth separation requirements, taking account of individual radar sensor azimuth resolution capabilities and other relevant technical and operational considerations. If the resultant standard system area separation minimum requirement is in excess of 9.3 km (5 NM), consideration may again be given to the practicability of rationalizing the geographical value of radar position symbol sizes to enable the 9.3 km (5 NM) criterion to be retained for application on a symbol-edge to symbol-edge basis.

2.10.2.3.2 Experience with the use of mosaic displays, provided by radar data processing systems of the type described in 2.10.1.3.3, is also limited. In this case, however, the controller can be informed by radar map data, or appropriate target labelling, from which radar sensor site the position data are derived. It would therefore, in theory, be possible to define separate criteria for range and azimuth separation purposes with each sensor; however, from the application viewpoint it would be cumbersome and cause considerable orientation problems for the controller. It is therefore suggested that it would be best if a general separation criterion were established along the lines proposed in 2.10.2.3.1 for application throughout the system area.

2.10.2.3.3 More experience has been gained in the use of digital SSR position information superimposed on raw video primary radar position data derived from a geographically separate site, as discussed in 2.10.1.3.4. Experience has shown that the raw video primary radar position data should normally be used for separation purposes, even though the provision of separation between the superimposed SSR position symbols of target aircraft

is relatively straightforward, the special considerations regarding separation minima being as discussed in 2.10.2.1. The real problem arises in determining which minima should be applied, between the SSR position symbols of target aircraft and the raw video primary radar targets of other target aircraft derived from a separate radar site

whenever it is necessary to provide radar separation to aircraft in such circumstances. The criteria established for this case have to take account of general registration inaccuracies between the two sets of position data, particularly including errors arising from slant range/true range anomalies.

Chapter 3

Application of Automation in Air Traffic Services

3.1 INTRODUCTION

Although the application of automation in air traffic services (ATS) is a relatively recent chapter in the much longer story of the development of computers, use of automated assistance in air traffic control (ATC) with varying degrees of sophistication is increasingly common. Implementation of these systems still tends to be a long and complicated process, usually based on detailed technical and operational requirements. Despite different requirements, resulting in different designs of automated systems and varying degrees of application, there are nevertheless a number of common principles and considerations. The following information sets out those common principles and considerations which may be used to guide the introduction and expansion of automated assistance in ATC systems and related ATS automation applications.

3.2 MANAGEMENT CONSIDERATIONS

3.2.1 Need for automation

3.2.1.1 Air traffic control systems need to keep pace with the continuing increase in air traffic which usually increases the controllers' workload disproportionately and causes the ATC system to approach the limits of its capabilities. Reducing the size of the airspace assigned to individual controllers in order to alleviate this situation results in an increase in the number of control sectors. The net result is an addition to the number of controllers, and an increase in the required inter-sector co-ordination and transfers of control, workload and complexity in the ATC system. Further subdivision will not increase the system capacity significantly and often does not justify the increased cost.

3.2.1.2 As a consequence of critical fuel supplies and soaring fuel prices, there is continuing pressure for improved flight efficiency. In the field of air traffic control, this requires improved flexibility, reliability and service, increased capacity and improvements in over-all

cost-effectiveness. A comprehensive and critical study of the functions, procedures and processes of a manual ATC system (non-radar ATC only or ATC enhanced with primary surveillance radar and/or basic secondary surveillance radar (SSR)) may result in changes which refine and rationalize the ATC system to such an extent that automation is not yet required. On the other hand the study may show that further improvement in efficiency can only be achieved by the application of automation.

3.2.1.3 Automation is justified if further improvement in efficiency is required:

- a) when any particular ATC functions or processes are becoming too burdensome or time-consuming to be carried out by human operators alone;
- b) when substantive improvement with regard to regularity and expedition of operations cannot adequately be obtained by other means;
- c) when safer or more efficient service is obtainable through introduction of automation.

3.2.1.4 Justification of the cost associated with automation is complex. Consideration must be given to the costs associated with:

- a) development of a long-term automation plan;
- b) buildings to house the equipment and associated technical services;
- c) computers, displays, sensor interfaces, associated peripherals, spare parts and other equipment;
- d) development of computer programmes (operational, support and diagnostic programmes);
- e) supporting documentation;
- f) training and maintaining of programming and technical teams;
- g) operational trials and evaluation (e.g. flight checks, system integration);
- h) training of ATC personnel;
- i) equipment and software maintenance and modifications;
- j) inter-unit communications requirements;
- k) monitoring of system performance.

While it is relatively simple to estimate the initial capital cost and the operating cost, it is not always possible to quantify the benefits.

3.2.1.5 The over-all cost-effectiveness of automation should not be determined on the grounds of any expected immediate savings in cost. A more effective utilization of the airspace, greater airspace capacity, less traffic delay and the ability to handle an increasing volume of air traffic may cost less when automation is employed. The extent of such savings and general benefits depends largely upon a balanced and economic introduction of automation.

3.2.1.6 There are a number of advantages or benefits which may result from automation in air traffic services, e.g.:

- a) improved management of air traffic services:
 - better airspace subdivision and utilization;
 - better provision of facilities and staffing;
 - increased ATC system capacity;
 - reduction in delays;
 - improved cost-effectiveness;
 - improved air traffic flow management;
- b) increased safety:
 - reduction in extended excess workload associated with stress;
 - reduction and timely detection of human errors;
 - enhanced continuity of surveillance, including SSR Mode C altitude data;
 - provision of better means for co-ordination and transfer of control;
 - automatic conflict and minimum safe altitude alert;
 - continuous monitoring of system performance and automatic warning of any deviations;
- c) improved service through availability of current data:
 - automatic filing and updating of meteorological (MET) and aeronautical information services (AIS) data for selective recalling by controllers, pilots and briefing officers;
 - timely provision of most recent and accurate data to controllers, including current flight plan data;
- d) availability of recorded data for:
 - accident and incident investigations;
 - administration of user charges;
 - search and rescue;
 - diagnosing and correcting hardware and software malfunctions;
 - system evaluation;
 - training; and
 - other purposes, via statistical analysis if required.

3.2.2 Long-term planning

3.2.2.1 The implementation of automation in ATS requires a detailed operational plan covering the time it will take to implement the automated system plus a certain period thereafter in order to ensure that the system will fit into the operational environment. Such an operational plan must contain a detailed specification of the procedures and working method.

3.2.2.2 The development of the operational environment (route structure, procedures, etc.) must be in accordance with that plan; if the need arises later to deviate, these deviations must be verified with the plan to ensure that both reality and development remain in harmony. System designers, particularly the software development staff, must work as an integrated team with the staff responsible for the design, implementation and execution of ATC procedures.

3.2.2.3 As a preparatory measure to the introduction of automation, the ATC organization and its supporting services should be rationalized to the maximum practicable extent. The analysis must take account of the services provided by adjacent ATS units and the need for compatibility in communications and other interconnexions.

3.2.2.4 Some of the questions which will need to be answered in developing a long-term automation plan are:

- a) at what point in time should the first steps be taken to implement ATS automation;
- b) to what degree will automation be implemented, both in the earliest stage and in the most advanced stages;
- c) what will be the relationship of the programme of automation with existent or planned systems in adjacent centres;
- d) how can future requirements be identified and expansion capabilities be quantified; and
- e) how can successive steps in a phased automation plan be implemented with the least possible disruption of the ATC operations.

3.2.2.5 Implementation planning

3.2.2.5.1 The capacity of the ATC system must be in balance with the anticipated traffic. Therefore, traffic forecasts should be made, in consultation with airspace users, for at least as much as a decade into the future. Preferably, the traffic analysis should permit an assessment to be made of the relationship between the increase in traffic and the increase in system load. This will allow

prediction of the point at which the ATC system will reach the limit of its capacity while using existing control techniques and resources. Not only the number of aircraft should be taken into account, but also the distribution of traffic, the maximum instantaneous airborne count, the characteristics of the aircraft involved, the ATC environment and the working methods. The points in time should be determined at which the introduction, or each further stage of automation, is justified for economical, practical or other reasons.

3.2.2.5.2 Experience has shown that it is extremely difficult, if not impossible, to forecast the development of air traffic with sufficient accuracy. Different scenarios invariably lead to widely varying expectations of traffic growth. Since this kind of study cannot provide precise, reliable indications, the planning of implementation of automation will need to be reviewed on a regular basis, e.g. once every year.

3.2.2.6 *Degree of automation*

3.2.2.6.1 The long-term automation plan should show which ATS functions are to be automated and the order in which this should be done. An automatic system may be built up and installed stage by stage. It should not be necessary to install the complete system before any advantage can be obtained from it. However, an attempt should be made to design the first stage so that by development and addition, rather than replacement, the system can be made capable of performing more functions.

3.2.2.6.2 The first stage in the implementation of automation in ATC may be either flight plan processing with flight progress strip printing or radar data processing enabling continuous identification of radar plots and display of Mode C derived level information. Depending on local circumstances such as the size of the region, the number of control sectors and the traffic structure, flight plan data processing may be chosen as a first stage, as it enables improvement in the data displayed to the controller and facilitates co-ordination. However, in many cases, the first step has been the introduction of radar displays with labelled targets as the system permits an immediate reduction in controller workload. It is inadvisable to implement an integrated flight plan and radar data processing system involving flight progress display and strip printing, primary and secondary surveillance radar, labelled targets and computer-driven displays before sufficient experience has been obtained with a more limited application of automation.

3.2.2.7 *Planning on a regional basis*

Where a number of States in a region plan to introduce automation into ATS systems, planning on a regional basis is essential for those aspects of the systems that interact to ensure compatibility of equipment and procedures. Benefits to be derived from automation introduced on a piecemeal basis may be negated to a large extent by incompatibility of equipment and procedures in adjacent centres and only a coherent planning and development of ATS systems on a regional basis can be expected to result in an optimum, integrated ATS system. This planning should be applied to subjects such as automated flight data interchange, transfers of control, and SSR identity code assignments. Proper consideration at the regional level of such matters facilitates planning for automation by the individual States. Extensive application of ATS automation in a region may lead to recognition of the need for improvements which result in more efficient service to aircraft operators.

3.2.2.8 *Transition aspects*

3.2.2.8.1 The implementation of automation in an ATC environment might involve some basic changes in procedures, airspace structure, equipment and operations. Moreover, the ATC system must operate continuously while installation and checkout of automatic data-processing equipment take place. Therefore, the problems associated with the transition from a manual to an automated system must be carefully considered. In particular, it can be expected that:

- a) equipment changes will have to be made at the operating positions;
- b) major equipment changes will necessitate complete renewal of operations and equipment rooms or even new ATS units or centres;
- c) re-organization of the airspace might involve changes in assigned air-ground communication frequencies, number of operating positions and procedures;
- d) training and adjustment of personnel to the new equipment and procedures will be required.

3.2.2.8.2 It is advisable to consider establishing an experimental unit operating under carefully balanced conditions duplicating or simulating the operational environment. At this unit, many aspects of introducing automation at the working level can be studied to provide useful guidance on staff organization and workload, equipment layout, etc. Ideally this unit should be so situated as to permit the circulation of operational ATC

staff through the system as the first step in familiarization and training, once the development of the system intended for operational use has sufficiently advanced.

3.2.2.8.3 In an experimental unit established on a temporary basis, use may be made of computers and peripheral equipment including input devices and displays intended for operational service. A permanent experimental unit, for use also after commissioning of the operational system, has obvious advantages, as it affords the capability of continuing research and development in a real-time environment. The use of equipment identical to that in operational use has the extra advantage that the equipment may provide (additional) back-up in case of failure of the operational equipment.

3.2.2.9 *Maintenance and modification*

Once automated aids in ATC have been developed, there is a continuing need for maintenance of hardware and software. Maintenance staff should be immediately available, either on a permanent basis or on a contractual basis to ensure continued availability of the system. Also, modifications will be necessary — in particular modifications to the software, to keep in step with new operational requirements. Ease of maintenance and modification are primary design considerations in air traffic control applications, necessary to make an automated system acceptable.

3.2.3 **Human factors**

3.2.3.1 Initially, automation designed to reduce excess workload of ATC staff in the processing and dissemination of flight plan data, to improve the quality of the data displayed to controllers and to enhance their communications systems, is generally beneficial to ATC. Such automation would not change the role of the controller, although it may give him additional tasks in providing information to the computer. A further stage in automation comprises facilities to take over, or assist in, some of the controller's less complex decision making tasks, without significantly changing the ATC system or the responsibilities of the controller. Extension of the application of automation beyond this stage will undoubtedly necessitate some fundamental changes to ATC procedures and the role of the controller.

3.2.3.2 Despite all the emphasis on excess workload and resulting stress as a problem in air traffic control, the greater long-term problem appears to be boredom. With increased automation the emphasis gradually changes from the man driving the machine to the machine driving the

man. In automated systems this may result in controllers acting in response to indicated events and conditions imposed by the computer. Equipment that is effortless and easy to use may reduce the role of the controller to that of a monitor of traffic and lull him into a sense of false security. It may also reduce the sense of challenge and job satisfaction. In air traffic control it is essential for job satisfaction to be able to develop skills and to have opportunities to use them, while under-utilization of a controller's skills may decrease his awareness of the situation and may prevent appropriate reaction in case of system failure.

3.2.3.3 Job satisfaction will be increased by keeping the controller in control, possibly including control over workload in automated systems which allows more to be done manually by the controller when traffic is light. Since job satisfaction and other human factors such as skills and professional pride contribute to the safety and efficiency of the ATC system, these human factors, important in any ATC system, should be included in the criteria for determining the extent of automation in ATC.

3.2.3.4 The application of automation will eventually require new and different tasks to be introduced for controllers. Controller training to accommodate these changes is most important, since controllers rely greatly on experience gained with the system through constant exposure to live traffic. If the system, including equipment, changes significantly, a period of retraining is necessary to re-establish confidence and develop experience with the new equipment and procedures. Therefore, it is essential that any such changes be evolutionary and that drastic changes be avoided.

3.2.4 **Controller contributions**

Participation by controllers in formulating the operational requirements and in all subsequent phases of the design, development and implementation of new systems is essential to arrive at optimized automated assistance for ATC. Contributions of selected operational controllers and supervisors are needed to design a system which responds to the needs of the controllers in performing their tasks. In addition, the selected operational staff can form the hard core of the instructional team for the familiarization and training of other operational staff. Such controller participation throughout the automation project will undoubtedly facilitate controller acceptance of new or modified automated assistance as an integral part of their performance of ATC functions. Such ready and willing acceptance is crucial to the realization of expected benefits through the introduction of automation.

3.3 ATC SYSTEM CONSIDERATIONS

3.3.1 ATC analysis

The introduction of automation may require a new analysis of the number and locations of area control centres as well as the subdivision and stratification of the airspace under the jurisdiction of the control positions. Such an analysis may even include projection across State boundaries to consider the bilateral or multilateral operation of a single area control centre. Since many complex factors are involved in the delineation of airspace and the allocation of responsibilities for the provision of air traffic services, simulation studies may be necessary to optimize the ATC system.

3.3.2 Automation as a part of a balanced system

3.3.2.1 In establishing operational requirements for the introduction of automation into a particular ATC environment, careful consideration needs to be given to the degree to which the associated sub-systems have been implemented. Automation is one step in the progressive evolution of ATS systems. In order to take this step it is necessary to maintain a continuous balance with other features of the system such as:

- a) the extent and quality of the navigation, communication and surveillance radar coverage;
- b) the availability and quality of airborne navigation and communication equipment;
- c) the flexibility of the airspace organization, control methods and internal communications equipment;
- d) the need for compatibility with equipment and working methods adjacent centres, whether such centres are employing computers or not.

3.3.2.2 An assessment of the degree and extent to which automation can be effectively used depends on a balance with all the other associated systems as listed above. An unbalanced implementation of automated processes is operationally and economically unacceptable.

3.3.2.3 The availability and quality of airborne navigation, communication and other equipment can have a significant effect on the performance of the ATC system in the areas of high density traffic. In these areas, lack of certain equipment in many of the aircraft desiring service, or failure to assure an adequately high level of performance from the equipment carried, can negate to a large degree the benefits expected from improving the ground portion of the system, by lowering the effective capacity of the

airspace. Consequently, the addition of automatic data processing equipment and the introduction of other improvements in ground installations must be balanced by the carriage of suitable high-quality airborne equipment, e.g. SSR transponders, standardized navigation equipment and multi-channel communications equipment.

3.3.2.4 The plan for implementation of automation must allow for flexibility in airspace organization and delineation of the airspace under the jurisdiction of specific controller teams. The increased capacity of a control position in a centre can be turned into real benefit only if the delineation of the airspace under the jurisdiction of that control position can be modified, as required, to the optimum configuration. This, however, will not be possible if the necessary airspace re-organization is constrained by restrictions in communications or radar coverage.

3.3.2.5 The effectiveness of all automated processes is dependent on a rapid flow of data. These data must be stated in a precise manner and in an agreed format. Therefore, any data supplied to an automated ATS unit should be compatible with the system's requirements, both technically (in respect of signal characteristics) and operationally (content and format). However, cognizance must also be given to the need for automated units to deal with adjacent non-automated units in a manner which will not obstruct the work of the latter. For example, the use of extremely abbreviated forms of data which are perfectly logical in ATS data interchanges with non-automated units can be completely unacceptable to manual units, which require the use of self-evident codes or plain language, readily understandable by human operators.

3.3.3 Relations to ATS communications

Implementation of automation in an ATS environment requires a re-evaluation of the communications sub-system to take account of the following:

- a) the possible change in the configuration and location of the centre requires that special consideration be given to the problem of transmission of radar information from the remote radar antenna sites and of communications from the air-ground communications sites;
- b) the possible re-organization of the airspace may involve a re-assignment of air-ground frequencies and the rearrangement of communications terminations;
- c) the changes referred to in a) and b) above may involve a re-arrangement of ground-ground voice and data communication networks;
- d) the data communication network may comprise the low speed aeronautical fixed telecommunication network

(AFTN), the medium and higher speed common ICAO data interchange network (CIDIN) and direct computer-to-computer links.

3.4 AUTOMATION PROJECT CONSIDERATIONS

3.4.1 System design and development

3.4.1.1 The electronic computer cannot perform a single function without being instructed precisely what to do in a logical, step-by-step manner. Telling the computer or "hardware" what to do in the form of a "programme" or "software" requires that the functions to be performed be first examined in minute detail. Programming is the process by which a set of instructions is produced for a computer to make it perform the required functions. The programmer plays a vital part in the implementation and development of the data processing system. In ATC his task is particularly demanding in that he is programming for a real-time environment with complex man/machine interface problems. Manual inputs should be facilitated to the maximum possible extent and stringent response time requirements should be met. The programmer needs to exert his skills to generate a software environment in which the controller may exercise his own particular talents. A multidisciplinary approach to the problems is essential and harmonious interchanges between software engineering and controller staffs are required throughout initial software development as well as after implementation.

3.4.1.2 Either the computer systems manufacturer, or a separate organization, in close consultation with a group of State ATS and computer experts, could with benefit assist in the design and development of the new system and in the provision of first-stage computer programmes. Normally, the manufacturer or vendor will provide the system software (operating system and support programmes) and the State will assume responsibility for the development and maintenance of application programmes. It is a matter for the State concerned to decide to what extent it may be necessary to maintain contractual arrangements with the manufacturer to provide post-implementation programming assistance. It is also possible to purchase a complete "turnkey" system from industry after issuing a specification. Close consultation between provider and customer should nevertheless be maintained during development. Once a complete set of specifications defining the first stage computer programme is agreed and a contractor is selected to build that programme, changes to this specification should be kept to an absolute minimum. The more

changes introduced at this stage, the greater will be the delay in final implementation and the cost of the system.

3.4.1.3 The State can be considered to have two basic needs in respect of programming staff:

- a) to provide a consultant group of ATS and engineering experts with previous applications software training. This group should actively participate with the manufacturer's team in the system design, system analysis and system implementation studies;
- b) to select a multi-disciplined team of software engineers and ATS system experts for training as "in-the-field" programmers, i.e. to establish the necessary programming expertise and strength to maintain and develop the operational programmes and the maintenance programmes.

3.4.1.4 The selection and training of staff must be undertaken at a very early stage if the State is to be adequately prepared to maintain the automatic data processing system, and care must be taken not to underestimate the requirement. The extent of the training necessary and the number of staff required is related to the nature and complexity of the data processing system. In general terms, training of programmers can be expected to extend over several months and a fully "independent" programming capability will not normally be achieved in less than 12 months. When selecting staff for the ATS software development team it is to be remembered that the individual to be selected:

- a) should have a good mathematical or logical aptitude;
- b) must have an aptitude for the work and should not be directed to it against his own inclinations;
- c) should be capable of prolonged and close concentration and have the ability to analyse the ATS processes.

3.4.1.5 In sophisticated systems there will be areas of programming, e.g. in radar tracking problems, in which mathematical programming assistance may be needed. It is to be expected that after initial use of an automated system, expansion will become necessary to perform additional and usually more complex functions. While the programming associated with such expansion often can be undertaken by the operational software engineering staff, assistance may again be required. Expansion of a system is facilitated if sufficient spare capacity is available in the system or additional hardware and software modules can be easily integrated. The use of fully programmable general purpose computers for ATS applications has obvious advantages, e.g. they are off-the-shelf products and as such less expensive than special purpose computers; they can easily be replaced by larger, more capable, newer models made by

the same manufacturer and using the same software; an existing maintenance support network may facilitate the maintenance and contribute to a high operational availability.

3.4.1.6 If an automation project involves the development of several operational centres, software modifications and additions should not be developed separately for each specific site, but should be considered for use in all operational centres. However, different local situations necessitate different software in many cases. Changes in and additions to the software for a particular site should be specified, documented, tested and implemented with great care, under central control. Such changes should not be implemented if they endanger the over-all integrity and reliability. The risk of reduced reliability is minimized if such changes are kept to a minimum compatible with local requirements.

3.4.2 Installation and testing

3.4.2.1 The problems attendant on installation and testing of an ATS automation system will vary according to its size, complexity and the types of equipment employed. For a large system where, for example, several radar systems and numbers of peripheral input/output devices and displays are supplied separately from the computer system and its programme, an administration may require independent contractual support to ensure proper integration of the various sub-systems and their testing. Diagnostic routines or programmes will need to be prepared to subject the system to the many different types of demands to which it will need to respond in operation. Ideally, these routines will require the system to repetitively perform each operational function that it has been programmed to do in a random fashion to the point of overload. Testing of overload protection, which should be defined in the system requirements, is of particular importance since such protection is a prime consideration to avoid system outages or derogation. This series of tests would be designed to evaluate how well the hardware meets the specifications imposed on the manufacturers, and is apart from operational testing that will be required prior to actual use for air traffic control.

3.4.2.2 Operational tests are necessary to ensure that the total system (hardware and software) meets its specifications. These tests may best be designed by members of the ATS staff in consultation with representatives of the system suppliers. The tests should be performed by ATS personnel to assure their acceptance before the system is made operational. A large system may be planned to be introduced into the operational environment in stages.

Testing likewise would be sub-divided to fit the same stages. These tests most likely will disclose a need for computer programme changes, and this would be the best time to accomplish them. Additional programme modifications can be expected to be required after the system achieves operational status in order to keep in step with changing operational requirements.

3.4.2.3 Acceptance of a system is a complex operation which must be clearly defined in advance. Specifications should be laid down not only for the initial acceptance procedures, but also for testing and acceptance procedures of subsequent modifications throughout the life of the system. Tests and evaluations in certain areas, e.g. radar tracking, should not be based only on subjective controller appreciation. Some very effective modern methods of evaluations are available, based on off-line data processing, to supplement the controllers' judgement. Simulated traffic and radar data may be used for this purpose. However, the additional use of actual, recorded data in the final stages of testing is desirable in order to identify and locate faults in the system which otherwise would become apparent only during operational use of the system.

3.5 DATA PROCESSING IN ATS.

3.5.1 Applicability

Air traffic control relies on the timely availability of accurate information, including MET and AIS data, aircraft intention and aircraft position data. Aircraft intention and position data are derived from the flight plan and surveillance radars. Co-ordination with other controllers and ATS units requires voice and data communication facilities. Automation may initially be applied in one or more of the above-mentioned areas. Further extension of the application of data processing may involve some of the tasks in air traffic control and air traffic management.

3.5.2 Flight plan data processing

3.5.2.1 One of the first questions to be decided will be the means with which the flight plan data should initially be entered into the ATS system. A filed flight plan or repetitive flight plan listing is the initial source of flight plan data. Even in early stages of the implementation of automation, manual input of such data in ATS computers should be minimized. This can be achieved by a direct input from the AFTN. Initial flight plan data processing should

include checks of the ATS data on accuracy, validity, completeness and compliance with ATS data conventions in order to minimize errors arising from the completion of flight plan forms and manual computer input. These checks are equally applicable to flight plan data received by the computer directly from the AFTN and would result in the rejection of AFTN messages in which errors are found. Correction and completion of AFTN messages which are rejected by the computer will have to be performed by specially trained staff within the ATS unit, who will also obtain flight plan data from the accepting offices via teletypewriter circuits, telephone or other means.

3.5.2.2 The checks performed by the ATS computer on ATS data received should preferably also be performed at the point of origin, i.e. before transmission of filed flight plan messages and other ATS messages via the AFTN, as this would eventually result in a significant reduction in the rejection rate of received messages. Computer-assisted ATS message preparation will allow a considerable reduction in human-originated errors. To this effect, microprocessor technology may be used in intelligent terminals, which would replace the commonly used teletypewriter as an input device for ATS messages to be transmitted via the AFTN. Reduction of errors at source will not only facilitate the automatic processing of the data by the receiving computer system, but is equally important for non-automated areas.

3.5.2.3 Reduction in input workload, in errors arising from manual input and in the loading of communication channels can be achieved by the use of repetitive flight plan procedures. If this is required, provisions should be made to store repetitive flight plans in the computer system and to process them automatically on the appropriate day and time. Where adjacent centres provide current flight plan data on flights entering from their areas, repetitive flight plans need be stored only for flights taking off from aerodromes within the planned centre's area, since current flight plan data on flights entering from other areas will be more up to date than data which might be obtained from the original stored filed flight plans. However, there may be other reasons for storing all repetitive flight plan data, e.g. for air traffic flow management purposes or as back-up information for air traffic control purposes. It is better to have some data in good time which may be incorrect and incomplete than to have no data at all at the scheduled time in the event of temporary degradation of system performance.

3.5.2.4 Manual input and the associated disadvantages may also be minimized by remote input of flight plan data directly from the originator's computer. Adequate auto-

matic checking of the input is required in order to ensure that the responsibility of ATS for the accuracy of the flight data is not compromised.

3.5.2.5 Even when there are several ATC centres in a State, it may be useful to have a single centre for initial processing of flight plans, submitted at different air traffic services reporting offices or received via the AFTN or otherwise. This would facilitate the establishment of a flight plan acceptance "feedback loop", which would inform the originator of the filed flight plan message and the operator or the pilot of the results of the initial flight plan processing. This "feedback" should result, through a learning process, in reduction of errors in the completion of flight plan forms and filed flight plan messages. Ideally, this concept of a dialogue between operator or pilot and air traffic services should be extended to include confirmation to the operator or the pilot of the acceptability of the flight plan for all ATS units concerned.

3.5.2.6 An automatic flight plan data processing system enables improvement in the accuracy, timeliness and display of these data before the controller, and reduction of the work at the control desk and of the load on inter-centre voice channels. The display may take the form of printed flight progress strips for posting on existing flight progress boards. Given the geography of a control area (ATS routes, etc.), wind data and the content of the current flight plan, flight progress strips can be prepared on suitable printers with computer-calculated time estimates for all required reporting points. Preferably, decentralized printers should be used, allowing strips to be printed immediately adjacent to the control positions.

3.5.2.7 The flight progress strip offers a very convenient means of allowing revision and rearrangement of data on a flight progress board, but it can only be updated manually. Additionally, manual computer inputs are required to keep flight plan data current in the computer. With the installation of specialized ergonomic devices, e.g. functional keyboards, for use by the controllers in updating the current flight plan data stored in the computer, properly identified updated strips may be printed as flights progress through the system. Instead of providing updated strips, it may be preferable to present only the revised data on paper strips or on an electronic data display to the controller. In writing the revised data on the existing strips, the controller's attention is drawn to the changes. Additionally, the controller does not need to transfer annotations, e.g. heading instructions, to the new strips.

3.5.2.8 At the same time, since the current flight plan data are updated with aircraft position reports, cleared and

reported level changes etc., this information may be transferred not only from one control position to another, but also from one centre to another at appropriate times. This offers a major improvement in reducing the voice communication workload of ATS staff and increases the accuracy with which this information may be transferred.

3.5.2.9 While computer-printed strips offer advantages such as enhanced readability and improved accuracy, consideration should be given to advanced electronic displays which now are available with the required reliability. The flight progress strip must be supplemented or superseded by electronic devices if real progress is to be made in automating the processing of flight plan data. Developments in electronic tabular and geographical displays (e.g. cathode ray tubes (CRTs), light emitting diode or liquid crystal displays, and plasma or electroluminescent panels) are looked upon as definite advances in the technology of offering the controller alternative means of presenting flight progress data. These displays have the advantage that they are concurrently updated by the manual computer inputs required to update the current flight plan data stored in the computer.

3.5.2.10 Where a combination of non-radar and radar control is being performed by a controller team, a relatively limited amount of data is displayed in tabular form adjacent to the radar controller to supplement the traffic picture presented on the radar display. For the foreseeable future a flight progress board form of display may still be required for use in traffic planning where longitudinal separation criteria expressed in time have to be applied. However, progress has been made in the use of electronic plan view displays for this purpose and for non-radar control.

3.5.3 Radar data processing

3.5.3.1 The output of the radar analog data system precludes its direct input into the ATC digital data processor. The conversion of analog radar data to digital form is done by means of a plot extractor. Primary surveillance radar plots as well as SSR plots have to be extracted separately. A simple form of radar data processing is to process SSR data only, using digital radar displays. If required, primary radar video displays may be used with digital SSR data superimposed thereon.

3.5.3.2 Display of the 4-digit SSR code and Mode C derived level information in tags or labels adjacent to each particular radar blip facilitates the identification of the

radar blip by the controller and provides altitude verification independent of pilots' reports.

3.5.3.3 Plot messages received from the plot extractor on a particular target aircraft in successive antenna revolutions can be correlated by the application of a tracking programme. Provided that a specific 4-digit SSR code is received only once per antenna revolution, a tracking programme can be relatively simple. However, in most cases additional features are required in the tracking and display software to overcome known difficulties inherent to SSR such as "fruit" (unsynchronized replies on the radar display), garbling and reflections, adding to the complexity of the radar data processing. A useful addition to the software, without unduly complicating the tracking programme, is a check on the receipt of a duplicate 4-digit SSR code within each antenna revolution and the generation of a warning on the controllers' displays when such duplication occurs.

3.5.3.4 Manual input of an SSR code and the corresponding call sign allows identification of the track concerned and display of labels containing call sign and altitude. This relieves the radar controller of having to remember which radar target belongs to which aircraft. Where several control sectors are involved, it is obviously advantageous if only one single input is required to replace the SSR code by the call sign in the label on all radar displays. Such code/call sign conversion would also be possible without automatic tracking of SSR replies. However, extra precautions are required to prevent misidentification when a duplicate SSR identity code is received.

3.5.3.5 Another potential benefit derived from incorporation of SSR data in the automatic data processing complex is the ability to allow simple filtering of data displayed on the controller's radar display. For example, SSR level data may be used to suppress the display of SSR responses from aircraft above or below the airspace under the jurisdiction of that particular controller.

3.5.3.6 Where both primary and secondary radar data are to be converted to digital form and the radars are located at the same site, primary and secondary plots which appear to result from the same aircraft may be combined by the plot extractor. The tracking process is more complicated than would be the case with secondary radar data alone, since primary plots have to be used to update secondary tracks in the event that temporarily no secondary plot is received, e.g. caused by shielding. Additionally, many radar echoes from targets other than aircraft (false echoes)

result in a substantial number of spurious primary plots, thereby adding to the processing complexity.

3.5.3.7 A next step would be tracking of primary plots. A significant reduction in processing time can be achieved by tracking only those primary radar targets which are identified by the radar controller. This requires a manual input by the controller on an *ad hoc* basis to permit labelling of aircraft with an unserviceable transponder or exempted from the obligation to carry a transponder in compliance with States' regulations. However, if the processing capabilities include tracking of all primary plots, false echoes may be suppressed and the tracking process may be improved. Combination of primary and secondary plots by the plot extractor may depend on relative position only. If, however, separate tracking processes are used to produce primary and secondary tracks, correlation of these tracks includes a speed criterion, which results in more reliable tracks.

3.5.3.8 The plot extractors may be located in close proximity to the radar equipment or to the ATS computer. When the radar equipment is situated at a considerable distance from the ATS computer, the plot extractor will usually be placed at the radar site to enable the use of less costly medium data rate (narrow band) communication channels to convey the data from the remote radar site to the ATS computer. If, apart from the digitized radar data, analog (primary and/or secondary) radar video is required for ATS, high data rate (broad band) communication channels (e.g. microwave radio links) will still have to be employed. In this case, the plot extractor may be located with the ATS computer. Similarly, a broad band channel may prove more suitable where the radar site is at a relatively short distance from the ATS computer. A cost versus effectiveness study would be appropriate to assist in evaluating these alternatives.

3.5.3.9 The ability to employ radar data from remote sites offers other opportunities for cost savings. Two or more ATS units may utilize data from a single radar site. An ATS unit also may share the output of a radar site serving a function other than air traffic control, e.g. one used for air defence purposes. In some ATS data processing systems, particularly those for use by area control centres, data inputs from two or more radar sites are employed to afford complete radar coverage of the centre's flight information region which leads to a requirement for composite radar data processing, possibly with multi-radar tracking or mosaic displays. This and other aspects of plot extraction and radar data processing are discussed in more detail in Part II, Section 3, Chapter 2, in which radar separation criteria are also discussed.

3.5.4 Integration of processed flight plan and radar data

3.5.4.1 There are many possible steps which can be taken in combining flight plan and radar data processing. The choice of steps and their sequence will vary with the requirements of individual States. Each phase of development from which the choice of steps might be taken is described below.

3.5.4.2 The first obvious step in the integration where area control centres are concerned, is the use of processed radar data supplemented to a small degree with flight plan data. In this step, only such flight plan data would be introduced that would be required to enable automatic radar target identification using SSR with 4-digit identity codes and the subsequent labelling of identified targets with aircraft identification and level data. This may involve only unprocessed primary radar with processed and tracked SSR for labelling purposes, or both primary radar and SSR may be processed for display.

3.5.4.3 A following step could introduce the automatic correlation of radar position data with the current flight plan. In this step the computer-extrapolated position of the aircraft in question (derived from the data in the current flight plan) is compared automatically with its radar position. Whenever the radar position along track differs by a specified parameter from the flight plan position, the current flight plan would be so modified automatically and estimated times over subsequent reporting points would be revised accordingly. Should the radar position reveal that the aircraft has deviated from the flight planned route by a specified parameter, the controller would be alerted. Similarly, the computer can monitor the vertical positions of aircraft using SSR level data and warn the controller of the possible need for corrective action. Revisions in current flight plan data resulting from the above process would be passed automatically to adjacent operating positions and centres.

3.5.4.4 Consideration should be given to the use of the automated processes for controller-to-controller co-ordination and for automated data transfers between ATS units, both centre-to-centre and centre-to-terminal unit. These may include:

- a) modifications of current flight plan data;
- b) controller-to-controller transfer of current flight plan revisions, e.g. changes in flight level;
- c) controller-to-controller transfer of control within an ATS unit;

- d) centre-to-centre and centre-to-terminal exchange of current flight plan data (current flight plan messages or estimate messages);
- e) centre-to-centre exchange of other co-ordination messages as appropriate.

3.5.4.5 Once a complete interface has been established between the plan position radar display and the tabular displays for flight data, integrated conflict search and warning routines are possible. These routines compare the predicted flight paths of two or more aircraft for the purpose of determining potential conflicts and display a warning to the controller when it is anticipated that the separation will be reduced below certain minima if no action is taken.

3.5.4.6 A conflict warning function may also be based on radar information alone, which permits conflict warnings also in respect of unknown traffic. Such a function requires, however, a considerable amount of processing, because, *inter alia*, tracking of all radar returns is required.

3.5.4.7 In ATC towers and approach control offices, certain area control centre-oriented functions are obviously not applicable. A first step in the application of automation here might be the automated preparation of flight progress strips using printers remotely operated from the computer at the associated centre. Assignments of SSR 4-digit identity codes made by the centre computer may be included on strips printed in the tower for subsequent delivery to pilots while taxiing for take-off. This ensures automatic SSR response identification before control is transferred from the tower.

3.5.4.8 Initiation and maintenance of automatic correlation between flight plan data and radar information requires assignment of one individual 4-digit code per aircraft. While the simplest method is the assignment of a fixed SSR code to each airframe or flight number, this method cannot be applied everywhere. Ideally, each aircraft within SSR coverage of any one centre should be assigned a protected code, i.e. a code which is not assigned to any other aircraft in the area. Advanced computer programmes may allow application of refined code protection procedures, such as:

- a) adaptation of the protection period to the actual period the aircraft is in the area;
- b) addition of geographical criteria related to the flight path to reduce the extent of the protection area;
- c) limitation of the code protection to a time period and area adequate to allow for unambiguous initial correlation (with subsequent transfer of maintenance of correlation to other criteria, e.g. flight path or altitude).

3.5.4.9 The next step in the application of automation in the unit providing approach control service might be in the form of improvements to the radar plan position display. The alphanumeric labelling of radar targets has been shown to offer considerable benefit. The use of the automatic identification and level transmission capabilities of SSR would facilitate radar transfers and provide three-dimensional position data. Establishment of data transfer communications between the centre and approach control computers would permit the exchange of current flight plan data, facilitating radar transfers between these ATS units.

3.5.5 MET and AIS data processing

3.5.5.1 Automated data processing and display techniques are particularly adaptable to the storage, processing and display of MET and AIS data required in the performance of air traffic control services. The ATS computer need not be used for this purpose as a separate system is often more practical. In fact, some administrations may find this to be a practical first step in automation.

3.5.5.2 It is presumed that the input of MET and AIS data is derived from sources outside the ATS units requiring them. Nevertheless, provisions may be included for both automated and manual inputs. In addition to MET data being used in calculating estimated times over significant points, the data would be processed for presentation in forms most suited to use by controllers and others in ATS units. One automated system might serve several ATS units through remote displays, with associated input devices to select data to be displayed. Some data might be transferred automatically to ATS computers.

3.5.5.3 Integration of ATS, AIS and MET systems offers advantages, e.g. in briefing of pilots. The dialogue capability of an intelligent terminal with an interactive display for flight plan filing having access to the AFTN could also permit access to weather data, NOTAM and other relevant AIS data. The terminal would thus become a "one-stop" briefing and flight planning terminal, providing all necessary MET and AIS data to pilots in addition to the feedback from ATS in response to the flight plan submitted.

3.5.6 Data recording and analysis

3.5.6.1 Recording of system data is required for various purposes. This includes data received by the computer, processed, displayed and transferred to other units as well as control actions entered by the controller. Analysis of these recorded data is a valuable aid for the correction of

errors in software and hardware, and will meet the needs for the investigation of accidents. For example, cleared flight levels and radar derived aircraft positions are crucial. Recorded radar data may also be used for search and rescue purposes. Additionally, further processing of recorded system data allows their use for planning and monitoring purposes, e.g. airspace and airport planning, system configuration and performance monitoring, as well as for user charges. The potential use for other purposes of recorded information should be considered. This may lead to additional requirements for recording and playback facilities. However, recording too much data might lead to deterioration of the total system performance and to increased response times as well as increased cost. Therefore, recording requirements should be balanced with system capability and other available resources.

3.5.6.2 For the recording of radar data, various techniques are available. A simple, but cumbersome technique is the use of film cameras or TV cameras and rotary-head video recorders to record the data on the controller's display. Digitized radar data may be recorded at various different data points, e.g. directly after the extraction of the primary and secondary surveillance radar plots, after the radar positions have been processed by the tracking process or after all software processing of the display data has been completed. If a playback system is designed to recreate, as closely as possible, the original viewing environment, software used in any recording or playback equipment should not compromise the data integrity. In order that the data actually displayed can be accurately reconstructed, display selections should ideally be also recorded, provided that this does not adversely affect the system's response times.

3.5.7 Communications

3.5.7.1 Data communications

3.5.7.1.1 Many switching centres in the aeronautical fixed telecommunication network (AFTN) are manually or, at best, semi-automatically operated. Each centre acts as a point for relaying messages, which are received on teleprinter terminals and re-perforated in the form of punched paper tape. Operators at these centres read the addresses on the messages and, where necessary, re-transmit them to the required destinations when the lines are free. In this process, delays inevitably build up.

3.5.7.1.2 An important increase in speed and efficiency in the handling of messages can be achieved with the use of computers. Reading addresses, deciding on the routing, calling and re-typing telex numbers are functions carried

out automatically. Full protection and security of both messages and circuits is incorporated in automatic systems. As a result of the almost total elimination of human intervention, and the comprehensive automatic checking of messages and circuits, the possibility of error or lost messages is considerably reduced. It should be stressed, however, that automated switching centres can perform efficiently only if the error rate in the received messages is extremely low, as rejected messages are routed to a manual position and are thus subjected to delays. Automatic systems store transmitted messages for short-term retrieval and for long-term retrieval as required. In addition, they log their own performance, providing daily statistical summaries. Users can thus see traffic trends and are able to assess the need for extra lines or other system expansion.

3.5.7.1.3 The importance for ATS messages of a reliable and efficient message switching system cannot be over-emphasized. Other categories of data, including MET and AIS data would equally benefit from the advantages of automated switching centres. An interesting possibility is the addition of a small flight plan processing module to the basic AFTN function of an automated switching system, by adding software elements and hardware components. In addition to increased efficiency, integrating the flight-plan processing with the message switching function provides automatic logging of all flight data inputs and outputs. In view of its essential function and potential integration with other systems, automation applied to a switching centre may be the first, essential step in ATS automation.

3.5.7.2 Voice communications

3.5.7.2.1 Voice communication facilities are essential in air traffic control. Co-ordination requirements are met by the provision of voice communication circuits between operators in one centre and between centres. With an increasing number of operating positions, the number of circuits has to increase even more, in order to retain flexibility in the system, where any two operators may require a voice connexion. Requirements for "hot" lines, direct access to external telephones, call transfer, conferencing and reconfiguration capability rapidly complicate a communication system to the extent that conventional techniques are no longer adequate to meet these requirements. The use of computer control allows circuit redefinition and total reconfiguration without hardware changes and thereby facilitates the expansion or contraction of operating position capability according to anticipated traffic volumes.

3.5.7.2.2 The communications facilities available to controllers should reflect the flexibility and re-configuration capability conferred by ATS data processing systems.

This includes re-assignment of air-ground frequencies and communications terminals. Integration of air-ground and ground-ground voice communications may simplify the operation of these systems by the controller. Provided that the required reliability is not compromised, a combined computer-controlled communications system is an obvious development to achieve the desired flexibility and simplification of operation.

3.5.8 Simulation

3.5.8.1 The use of simulation in ATC applications has obvious advantages. Simulation capability may be provided by additional software in the operational system, permitting use of the total system or parts thereof in a simulation mode, or by a separate simulator. While the first alternative may be cost-effective, depending on the system design, it may limit the simulations to non-critical hours of the operational system and degrade the availability of that system. Fully independent hardware and software for simulation provide more flexibility and have the potential of adding back-up hardware to the operational system.

3.5.8.2 Simulation capability has obvious value for the training of ATC personnel and may include scenario generation, problem execution, traffic situation freeze and playback features and objective measurements for individual performance. This capability becomes more critical as the role of the controller changes with advances in the operational system. It permits evaluations to be made of proposed changes to ATC procedures and functions of the operational system and “refresher courses” for ATC personnel before the changes are implemented.

3.6 MAN-MACHINE INTERFACE

3.6.1 The application of computers in ATS poses serious, often complex problems in the interface between the man and the machine. The computer is required to output a continuing flow of processed information on a routine basis, for display to the controller in an easily assimilable manner. This information includes radar and flight data supplemented in sophisticated systems by advisory and warning information. Also, the computer has to provide additional information on request, such demands requiring manual inputs. In order to provide these data, the computer has to be updated with information on actual aircraft positions, including flight level, and with information on

control actions which modify the current flight plans of individual aircraft, e.g. cleared flight level and holding instructions.

3.6.2 The need for manual input of current positional information may be reduced in advanced systems with automatic input of radar-derived positions which only occasionally has to be supplemented with manual inputs. However, control actions modifying a current flight plan require individual manual inputs in all cases until such time that the feasibility of automatic input can be demonstrated.

3.6.3 In the field of input devices, it is important to recognize that the purpose of the data processing equipment is to assist the human controller, and that he must not be made a slave to the machine. If input devices are chosen that require the controller to devote a large measure of his time to keeping the computer informed of his needs and decisions, the desired gain in his productive capacity will be lost, the expense of providing him this tool will be wasted and the growth of the system will be limited.

3.6.4 The usual input device associated with data processing equipment is an alphanumeric keyboard, similar to that of an ordinary typewriter. Combined with a CRT display for queuing of inputs, as required, and ease of editing, it becomes an input terminal that can, if desired, be used by a control assistant. Although the flexibility of this device makes it a valuable aid in some controller functions as well, the controller should normally not have to resort to extensive use of such equipment.

3.6.5 Input devices for the controller should be engineered to be functionally simple, involving him in a minimum number of input actions. Significant progress has been made in development of some specialized “ergonomic” devices for this purpose such as interactive “touch displays”. A functional keyboard, well designed from an ergonomic point of view is suitable in many applications. Various manually operated gating devices (e.g. “light pencils”, “track balls” or “joysticks”) are in use to identify specific data on a CRT display to the ATS computer. A computer programme can be so designed that data choices appear before the operator in several selectable series of questions and possible replies. One device specifically developed for ATS applications using this technique is a CRT tabular display with a grid type input sensor (for gating) superimposed over it. As a question/answer group appears, the operator touches the grid to select the appropriate answer to that question, whereupon the question/answer group next in order appears. Properly applied, a control action may be entered in the ATS computer with very few touches of the grid of such an interactive display.

3.6.6 An important aspect of input devices is the need for some form of display to be associated with the input device to permit the controller to confirm the correctness of data to be entered prior to their insertion into the computer, or to permit the computer to advise him when an input has been rejected because of content or format error not detected prior to insertion. In case of such a rejection, indication of the nature of the error is advantageous, as it assists greatly in a correct subsequent input of data.

3.6.7 A major problem to be solved in the development of advanced ATC systems is the determination of the content and optimum arrangement of the information shown on the display devices. Matters that may impair the controller's efficiency include:

- a) displaying too much data;
- b) incorrect and distracting use of colour and symbols on the display;
- c) displaying data either too early or too late with regard to its use;
- d) requiring the controller to actively engage too often in the real time acquisition of data;
- e) requiring the controller at inconvenient times to give his attention to matters not directly related to control; and
- f) displaying flight data in a tabular form in a predetermined sequence without sufficient flexibility for the controller to modify the sequence of the data.

3.6.8 Some display techniques may take the controller out of the data acquisition loop. For example, flight plan data may have been amended without his becoming aware of the amendment. It is necessary to involve the controller in important changes of displayed data to ensure that he is made aware of the changes. For example, by discrete highlighting of new and amended data until he acknowledges their presence it can be assured that he will take them into account in his planning and decision-making actions. The manual input required for such an acknowledgement could be used also as a data resequencing command, thus reducing the number of computer inputs by the controller.

3.6.9 Display of the present traffic situation and of aircraft intentions is required to enable controllers to make effective decisions. These data would be derived from current flight plan data amended by newly acquired aircraft position data as appropriate. A suitable display must enable the controller to relate the intended flight path of the aircraft concerned and the intended flight paths of such other aircraft as are in potential conflict with the aircraft concerned. In a radar control environment this is readily satisfied with a plan position type of display, supplemented with conflict detection aids. Similar displays may be used in a non-radar environment, e.g. in an oceanic

or other remote area. In this case, however, the display can only show computer-projected flight progress data extrapolated from actual position reports and using flight plan data. Although such a display may have advantages compared to the flight progress board, facilitating the assessment of the traffic situation, it should be realized that since aircraft positions are based on infrequent position reports, the display cannot be used as a "radar" display and non-radar separation minima will have to be applied.

3.7 SYSTEM RELIABILITY AND AVAILABILITY

3.7.1 Modern technology is indispensable in ATC, providing surveillance radar data, flight plan and other data and communications facilities to the controller. In the event of random, unpredictable equipment failures, controllers experience difficulty in providing unrestricted service, in particular during periods of heavy traffic. For this reason, the reliability of the various systems in use cannot be over-emphasized. This applies in particular to ATS computers on which controllers become more dependent with the progressive application of automation. Twenty-four hours a day operational service of these computers, accurate operation and uninterrupted system availability require an exceptionally high reliability of both hardware and software.

3.7.2 Over-all system reliability represents a complex amalgam of the independent reliabilities of the various sub-systems comprising the whole system. Choices will be required between standby units or channels and multiple redundant units or channels, or no back-up at all. Use of radar data from more than one location to maintain surveillance of a given portion of controlled airspace offers one form of redundancy. Redundancy in ATS computers may be achieved by the installation of two identical computer systems, the second processor operating in a standby mode. A high-speed, programme-controlled configuration switch facility may permit full automatic reconfiguration of the system in the event of processor or subsystem failure.

3.7.3 Alternatively, several processor modules may be so consolidated that multiple redundancy is achieved. Distributed processing must be seriously considered for air traffic control systems, since it allows the processor cost to be reduced while at the same time increasing reliability and maintainability, i.e. minimizing fault detection and repair time. Furthermore, expansion of the system through added capabilities can more easily be accommodated.

3.7.4 Each scheme offers different advantages and disadvantages which require that every sub-system be evaluated in a manner that will produce figures of merit according to which the performance of the over-all system may be judged. This can be achieved by providing design alternatives which can be explored to satisfy the particular needs of ATC. For example, should the data base be centralized for optimum maintenance or distributed for optimum retrieval? Should processors be functionally bound or have generalized capabilities? How much processing can be off-loaded into display console micro-processors? Should intracommunications be direct or are network communication delays acceptable? To answer these and many more basic questions, a rigorous analysis is needed. Simulation modelling is a modern technology aid to meet this need by providing assistance in determining optimum system design approaches taking into account the various operational and functional system requirements.

3.7.5 To accommodate local malfunction of equipment, parts should be replaceable easily and quickly when failure occurs. The most critical sub-system, perhaps, will be that which presents data for direct interpretation by the controller, such as flight progress strip printers and electronic display sub-systems. Displays, e.g. CRT displays, are of particular concern. Such displays should be designed to be reliable and "fail-soft". Reliability includes the provision of sufficient redundant channels to carry data to the display to permit some components of the equipment to fail without any resultant loss of the data displayed. "Fail-soft" or survivability requirements are met in the display system if it is so designed that, even if redundant equipment fails to the extent that loss of some data occurs, sufficient data remain on the display to enable the controller to continue operation, although with some difficulty. An example of a "fail-soft" condition is the loss of alphanumeric labelling data wherein it remains possible for the controller to continue working, albeit at reduced capacity, by mentally correlating aircraft identification with the related radar targets.

3.7.6 Data which is already displayed should not be lost in order to facilitate reversion to a back-up facility, e.g. a tabular display in support of a radar display. Channels from the computer to display devices may be duplicated to minimize the possibility of serious failure but the aim should be, even in this event, to provide efficient back-up display information to permit the continuation of service. Autonomous display units, receiving radar information directly from the radar sensors and bypassing a central computer containing flight plan information, will permit the continued display of aircraft, with labels containing SSR code and Mode C derived level information.

3.7.7 Obviously, software is also an important factor in the over-all system reliability. While the system is in operational use, the need for software modifications and additions will undoubtedly arise. Interruptions in the operational availability to implement these changes should preferably be kept to a minimum. Increased use of more powerful high level programming languages, structured programming techniques, automatic test facilities and a well-considered system release discipline facilitate a balanced implementation of subsequent programme versions with increased capabilities, while the required reliability is maintained.

3.8 DATA INTERCHANGE

3.8.1 Data interchange between ATS units

3.8.1.1 Benefits expected to be obtained from automation of ATS processes are greatest when their planning takes full account of the fact that ATS units do not exist in isolation, but operate as elements of a coherent network of units serving a wide area. The automation of individual units, therefore, should be planned with full regard to the exchange of flight data with neighbouring units on a computer-to-computer basis. Automated computer-to-computer exchanges assure the timely exchange of flight data in a fully dependable manner while at the same time reducing the manual input workload with its associated errors. The most benefits are to be gained from ATS automation by automating as many inputs of flight plan and other data as possible.

3.8.1.2 The following scenario exemplifies the savings possible in manual computer input workload. A filed flight plan is entered at the flight planning office on the keyboard of a microprocessor terminal. Computer assistance in the FPL message preparation will ensure a message checked for accuracy and thus free of obvious errors, which upon its completion will be transmitted to the ATS computer at the centre within whose FIR the flight will take off. Also automatically, the FPL message will be transmitted to those units which require advance information on future traffic, including "manual" centres and flow management centres. The computer in the first en-route ATC centre will convert the FPL message to a current flight plan assigning a 4-digit SSR identity code and will relay essential data to the tower and approach control unit serving the departure aerodrome. The SSR code is relayed to the aircraft before take-off. Upon identification after take-off, the approach control computer generates a departure message to the centre computer to update the current flight plan.

3.8.1.3 Within the centre computer, the current flight plan is kept current in the horizontal plane by automatic radar correlation and vertically by automatic inputs from SSR Mode C replies and manual inputs of changes in the cleared flight level as assigned to the aircraft. Twenty minutes before the flight is to enter the next centre's FIR, the current flight plan containing only data of interest in the future progress of the flight is automatically sent to the computer at that centre. This will be the first knowledge the new centre will have received about this flight. Receipt of the current flight plan is acknowledged and acceptance by the next controller of the proposed conditions of transfer, as contained in the CPL message, completes the co-ordination process. After a "silent" radar transfer, which does not require voice communication between successive controllers, the process continues as the flight proceeds from the second centre's FIR to successive FIRs until the aircraft arrives at its destination aerodrome or is transferred to a centre which is not equipped for automated ATS data interchange. Until this point en route, no filed flight plan was required for manual input of flight plan data, except for the initial input at the flight planning office.

3.8.1.4 The type of automated data interchange needed for computer-to-computer exchanges will vary according to whether radar control or non-radar control is exercised. Where only flight data processing is being performed for non-radar control, the demands for data exchanges will be less urgent by a considerable degree than where co-ordination and transfer is based on radar control. In the former situation, a slow data transmission speed (or rate) may be selected, while in the latter the need for quick response to co-ordination messages will dictate a requirement for choosing a data transmission rate sufficient to provide the needed system response time. Another consideration may be the means of detecting and correcting errors (error control). Over long periods of time low speed teletypewriter circuits have been used, without error control, for the exchange of filed flight plan messages and associated update messages. Because logic checks by the receiving controller can detect most significant errors in such messages, adequate over-all service has been obtained despite the obvious shortcomings of the communications system. On the other hand, computer-to-computer exchange of ATS messages requires a reliable form of error control.

3.8.1.5 The procedures and message formats for ATS data transfers set forth in Part VIII and Appendix 3 of the PANS-RAC primarily cover the requirements for data interchanges between area control centres. This is logical, because most international ATS data transfers using messages in automatic format will be conducted between

centres. The large variety of message types prescribed will also adequately meet most of the requirements for data transfers within a given State, including those between centres, approach control offices and aerodrome control towers. The advantages of using the same message types and formats within a State as well as internationally appear obvious. Such a practice would be very convenient for controllers and communicators, since they would be saved the inconvenience of having to receive and send data in one direction in one set of formats and in another direction in another set. It would also enable a computer to accept all its incoming data directly from the source of origin without human intervention and to generate its outgoing messages without unnecessary complication of programme routines.

3.8.1.6 As the introduction of new capabilities in the field of automated data processing generally does not follow a common time-scale, automated centres will be required to co-operate with adjacent non-automated centres during intermediate phases with due regard being taken of their manual capabilities. Thus, data transmitted from automated to non-automated centres will need to be sent in formats suitable for human interpretation using communication techniques then available.

3.8.1.7 Exchanges between ATS computers of flight plan data and other ATS messages should preferably employ the 7-unit coded character set (IA-5, International Reference Version). This enables use of input/output (I/O) devices designed for computer applications. ATS computer I/O capability should be compatible with the Standards and Recommended Practices (SARPs) and guidance material contained in Annex 10, Volume I. Interconnexion between computers serving different ATS units is most effective when data links employing medium and higher data signalling rates and error detection techniques are used. A medium and higher data rate network such as the CIDIN (Common ICAO Data Interchange Network) could serve equally well in lieu of separate point-to-point data links. Technical provisions relating to ground-ground data interchange at medium and higher signalling rates appear in Part I, Chapter 4 of Annex 10, Volume I, and guidance regarding such interchange, including material relating to the CIDIN, appears in Attachment G to that document.

3.8.2 Data interchange with other systems

3.8.2.1 The ATS system has relationships of various degrees with a number of other systems of which the meteorological, aeronautical information and air defence systems are the closest. The development of a MET data-processing system will permit the automatic transfer of MET data to an ATS computer and may also enable, for

example, the presentation of severe weather outlines on the controllers' plan view displays. In similar fashion, the ordered storage and dissemination of AIS information is ideally suited to automated data processing. In some cases this function has been incorporated with the MET data processing system, while in others it remains separated. Access to this data through ATS automated data systems offers an effective means of reference to AIS data within ATS units.

3.8.2.2 The relationship between ATS and air defence systems is more intimate and more in real time. Since the air defence system may have radar equipments covering some part of the airspace not covered by ATS radars, the resulting radar data could be made available in digital form to the ATS computer where this coverage or a portion thereof is needed by the ATS system. The ATS system can assist the air defence system by filling in gaps in the defence radar system with ATS radar data, and can assist in the identification of aircraft, particularly those entering from beyond the boundaries of national airspace. In addition to purely domestic ATS/air defence co-ordination, there may be circumstances in which air defence systems co-ordinate across an international boundary.

3.9 FURTHER AUTOMATION

3.9.1 Extended application

3.9.1.1 Extension of the application of automation in ATS may include calculation of the available capacity of a terminal control area or aerodrome within that terminal area, and balancing of this capacity with the projected load by suggesting gross acceptance and delivery rates. Provision of electronic tabular displays will allow more efficient arrival and departure sequencing through the use of automatic interchange capability between the centre and the unit providing approach control service. Determination of terminal area sequencing and spacing well in advance can allow more precise calculation of any expected delays and pilots can be informed of them early enough to absorb most of the time through speed reductions en route. In cases of continuing congestion, start-up procedures and co-ordination with successive centres may be necessary in order to avoid delays en route. It is obviously preferable, if a delay cannot be avoided, to hold an aircraft on the ground. Flow control combined with sequencing and spacing of aircraft entering or departing from a terminal control area will ensure minimum delay and maximum utilization of the available capacity of the ATC system.

3.9.1.2 The requirement for advance planning of traffic flows has led some administrations to establish centralized flow control units which require interchange of flight data with ATS units being served. In addition to long-term flow management based on airline schedules, data on past flights and capacity parameters, tactical demand/capacity balancing requires the availability of basic flight plan data updated by actual traffic data. In these areas a communications network such as CIDIN could facilitate the flight data interchanges required for dynamically regulating the air traffic flow.

3.9.1.3 Conflict search and warning routines may be extended to include determination of potential short-term, en-route conflicts. The ability to predict flight paths and conflicts, to determine acceptable alternative flight paths and display to the controller possible solutions of conflicts with a clear indication of their resulting effects on the whole traffic situation, provides computer assisted conflict resolution.

3.9.1.4 A minimum altitude warning function may be added to the automated system. Combined with appropriate logic, correlation of SSR Mode C altitude, aircraft position and minimum safe altitudes will result in a suitable warning on the controller's display if any aircraft equipped with an SSR Mode C transponder is below a specified minimum safe altitude.

3.9.1.5 Although weather data for display on the controller's plan view display may be obtained from a MET data processing system, ATC requirements may warrant a separate development. An existing surveillance radar may be used in conjunction with a weather extractor to provide digitized clutter data. Filtering of clutter at two different intensity levels would enable separate display of the "hard core" of showers. Presentation of severe weather should not cause overshadowing of displayed aircraft. For this reason, a careful choice should be made regarding the display method, e.g. shading of severe weather areas by radial lines originating at the radar station or presentation of severe weather outlines only. It should be noted that a two-level presentation of weather information is not totally satisfactory. However, a better presentation is not available within the existing technology, employing surveillance radar and monochromatic displays.

3.9.2 Technological developments

3.9.2.1 An important development in the area of secondary surveillance radar systems is monopulse technique, which allows a considerable improvement in accuracy of

azimuth data. Progressive implementation of this technique in SSR ground stations will alleviate the problems caused by over-interrogation. In addition to monopulse processing, enhanced surveillance processing is incorporated in an improved SSR system with the ability to select the aircraft from which it requests a reply. This improved SSR system is referred to as SSR Mode S. Previously, developments of SSR Mode S were known as Address Selective (ADSEL) SSR or as Discrete Address Beacon System (DABS). Each SSR Mode S equipped aircraft has a unique address code and selection of the aircraft to respond is accomplished by means of this address. The interrogator's ability to limit its interrogation to only those targets for which it has surveillance responsibility prevents surveillance system saturation caused by all transponders responding to all interrogators within line of sight. Additionally, appropriate timing of interrogations under ground computer control ensures that the responses from aircraft do not overlap, eliminating the mutual interference which results from the overlapping of replies from closely spaced aircraft (so-called synchronous garble).

3.9.2.2 Another advantage of SSR Mode S lies in the fact that its use establishes a two-way digital air-ground data link. With increased automation, both on the ground and in the aircraft, and increasing amounts of information to be transferred between ground and aircraft, voice communications and associated data-voice-data translation in the transfer of information is not practical. To support further automation, digital communications are being explored to supplement the voice communications. Many potential applications of the SSR Mode S data link have been suggested, including the air-to-ground transmission of airborne derived data, ground-to-air transmission of operational flight information, clearance confirmation, flight level assignments and other control messages.

3.9.2.3 ATS automation is going through a dramatic evolution due to major technological advances in such areas as microprocessors, memories and digital communications. Computer hardware is becoming smaller, cheaper and more powerful. To a large extent developments in memory-on-a-chip technology may obviate the need for external memories with their associated access times. The trend in the evolution of ATS computer systems has been to offload functions from the large central computer complex by making the peripherals smarter, both on the sensor side and the display side. The offload of current functions results in modularity, functional growth potential, high data integrity, reliability and operational availability and recoverability, which capabilities are inherent capabilities of distributed computer architecture. Significant improvements have also been achieved in the field of

input/output devices, which can be tailored to specific ATS requirements. Combined with the required software, further improvements may include speech recognition, which together with an interactive display could be used in lieu of a keyboard for data entry into the computer. Possibly in combination with output of synthesized voice, this would benefit the man-machine interface, allowing the controller to communicate with the computer without adding significantly to his workload.

3.9.2.4 Eventually, automation will undoubtedly necessitate some fundamental changes to ATC procedures and the role of the controller in the ATC system as the computer assists in, or partially takes over, the more complex strategic and tactical decision-making tasks. An obvious task for the computer is the provision of a suitable traffic flow management plan for a certain area. In addition to a strategic flow pattern, alternatives may be provided on request to allow evaluation of the effect of revised parameters before the plan is accepted. Tactical flow control on the basis of individual aircraft might benefit from automatic means to determine if restrictions are necessary regarding the route, altitude or time. Ultimately, this would result in ATC clearances which will guarantee that no delay will be experienced en route. A continuous monitoring of the air traffic flow and provision of information on anticipated imbalance in demand/capacity and the effects of possible remedial actions would enable optimum use of the available airspace and air traffic control systems.

3.9.3 Growth potential

3.9.3.1 When introducing automation in air traffic services, it should be realized that investments are being made in a field which is growing rapidly. While the capabilities of the initial automated systems may be limited, they should be so designed that by addition of software and, if necessary, hardware modules, the system can be made capable of performing additional functions. Many of these potential applications may be known at the initial planning stage. However, many future applications have not yet been defined, although their feasibility may have been demonstrated.

3.9.3.2 Full benefits of the investments in automated ATS systems can only be expected if the systems have sufficient growth potential to perform additional tasks, without the need for replacement of the total system. In order to plan future applications, it is necessary to keep abreast of current developments in the fields of surveillance, computer technology and communications and to

determine which of these developments lend themselves for future integration in the existing automated ATS systems.

3.9.3.3 With the increasing reliance on automated aids in ATS, it becomes increasingly important to minimize disruptions of the availability of these automated aids due to maintenance, upgrading or addition of modules. To this end, the system architecture should facilitate replacement and addition of hardware and software modules. Software

should be “portable”, i.e. capable of being implemented in newer computer models. If total replacement of a complex system will eventually become necessary, a phased replacement plan should be developed well in advance, in view of the extremely lengthy lead times involved. Such a plan should minimize the impact on the ATS operations by providing for separate implementation dates for changes in procedures, hardware and software, thereby permitting a continuing, virtually uninterrupted provision of service.

Appendix A

Glossary

Alphanumeric. Pertaining to a character set that contains letters and or mathematical symbols.

Analog data. Data in the form of continuously variable physical quantities. Contrast with digital data.

Application programme. A programme written for or by a user that applies to his own work.

Automatic data processing. Data processing largely performed by automatic means.

Automation.

- 1) The implementation of processes by automatic means.
- 2) The conversion of a procedure, a process or equipment to automatic operation.

Availability. The ratio of percentage of the time that a system is operating correctly, to the total time in that period.

Chip. An integrated circuit of many components on one or more minute layers of, e.g. silicon.

Computer.

- 1) A data processor that can perform substantial computations, including numerous arithmetic or logic operations, without intervention by a human operator.
- 2) A device capable of accepting information, applying prescribed processes to the information and supplying the results of these processes.

Data.

- 1) A representation of facts, concepts or instructions in a formalized manner suitable for communication, interpretation or processing by human or automatic means.
- 2) Any representations such as characters or analog quantities to which meaning is, or might be, assigned.

Data link. Terminals together with interconnecting circuits permitting the transmission of data between the terminals.

Data processing. The execution of a systematic sequence of operations performed upon data. Synonymous with information processing.

Data processor. A device capable of performing data processing, including desk calculations, punched card machines and computers. Synonymous with processor.

Diagnostic programme (routine). A programme (routine) used to locate and perhaps explain either a fault in equipment or a mistake in a programme.

Digital computer.

- 1) A computer in which discrete representation is mainly used.
- 2) A computer that operates on discrete data by performing arithmetic and logic processes on these data.

Digital data. Data in the form of digits or integral quantities. Contrast with analog data.

Discrete. Pertaining to distinct elements or to representation by means of distinct elements, such as characters.

Display. An output device that provides a visible representation of data.

Distributed processing. Processing by multiple data processors, usually interconnected.

Error. Any discrepancy between a computed, observed or measured quantity and the true, specified or theoretically correct value or condition.

Note.— An error may be due to a fault or a mistake, but errors also arise from lack of precision which is foreseen and accepted.

Fail-soft. Pertaining to a system design characteristic which, in case of redundant equipment failure, will enable continued operation of the remaining equipment, although with reduced capacity and efficiency.

Fault. The failure of a device to perform in the manner required over a specified range of environmental conditions.

Functional keyboard. A special purpose keyboard, designed for a specific application.

Garbling. The degradation of code information due to the simultaneous presence in a decoder of overlapping reply pulse trains.

Gating device. A device that controls a visual marker on a radar display. When the marker is positioned over or around a selected echo or radar position symbol on the display, positional or other information with respect to the target can be extracted.

General purpose computer. A computer designed to handle a wide variety of problems.

Hardware. Physical equipment, as opposed to the computer programme or method of use, e.g. mechanical, magnetic, electrical or electronic devices. Contrast with software.

High level programming language. A programming language designed for the convenient expression of a given class of problems or procedures used in a solution of a wide class of problems.

Input device. The mechanical unit designed to bring data to be processed into a computer, e.g. keyboard or a terminal.

Interactive display. A display which permits communication between the user and the computer involving step-by-step interaction in a "conversational manner".

Intelligent terminal. A visual display terminal with independent processing capability and storage capacity. Also called "smart" or "programmable" terminal.

Maintainability. The ability of equipment to be retained in or restored to a state in which it can perform its required functions.

Manual computer input. The entry of data into a computer or system by direct manual manipulation of a device.

Microprocessor. A small size, low cost computer contained on a single integrated circuit or a set of integrated circuits on a single printed circuit board.

Mistake. The failure of a human to carry out an operation in the required manner, e.g. in writing a programme or operating equipment.

Monopulse technique. A radar technique in which azimuth information of an SSR transponder equipped aircraft is derivable from each pulse detection by comparison of signals received simultaneously in two or more antenna beams.

Operating system. A collection of programmes forming part of the system software of an automatic data processing system used to enhance the utility of a computer by providing facilities during the execution of application programmes which are not readily built into the hardware.

Peripheral equipment. In a data processing system, any unit of equipment, distinct from the central processing unit, which may provide the system with outside communication.

Programme. In automatic data processing, a complete specification of a process to be performed on data, i.e. a schedule of actions, at least partially ordered in time, proposed in order to achieve some desired result.

Programmer. A person mainly involved in designing, writing and testing computer programmes.

Programming language. An artificial language specifically designed for expressing programmes.

Real-time. Pertaining to a mode of operation of a system in which the instants of occurrence of many events in the system satisfy restrictions determined by the occurrence of events in some other, independent system.

Reliability. The probability that a device will function without failure over a specified time period or amount of usage.

Response time. The amount of time elapsed between generation of an inquiry at a terminal and the receipt of a response at that terminal.

Routine. An ordered set of coded instructions that may have some general or frequent use to direct a computer to perform a desired operation or series of operations.

Shielding. The presence of an object, usually conducting, between the SSR interrogator and transponder antennas that substantially reduces the effect of the radiated electromagnetic fields.

Simulation. The representation of certain features of the behaviour of a physical or abstract system by the behaviour of another system, e.g. the representation of physical phenomena by means of operations performed by a computer or the representation of operations of a computer by those of another computer.

Simulation modelling. A design technique using a model of a system in the form of a computer programme. The model can be adjusted easily and the system that is being designed can be tested to show the effect of any change.

Software. A set of programmes, procedures and possibly associated documentation concerned with the operation of a data processing system. Contrast with hardware.

Software engineering. The definition of software development objectives and the optimization of approaches towards these objectives by the use of sound engineering principles and methods.

Support programmes. The programmes necessary to support and facilitate programming activities.

System software. Software whose primary purpose is to make a computer usable or to enhance its usefulness.

Terminal. A device, usually equipped with a keyboard and some kind of display, capable of sending and receiving information over a communication channel.

Tracking. The establishing of a track by the radar data processing system on the basis of received radar plot positions and predicted positions.

Turnkey system. A system which is designed, built, installed and tested and which the user receives with complete documentation, ready for use.

Chapter 4

ATS Data Management

4.1 INTRODUCTION

4.1.1 Air traffic control (ATS) relies on the timely availability of information on the progress of flights and pilots' intentions. The flight plan is the basic source for such information and as such is a vital link between the pilot and the controller in the determination of the conduct of flight. The amount and detail of specific information which an ATS unit needs to obtain from the flight plan is dependent on the function of that ATS unit. Area control or flight information centres (FICs) may require complete information, while approach control offices and aerodrome control towers may require considerably less information derived directly from the flight plan. In addition to the basic functions of ATS, flight plan data, in some cases, are also required for the purpose of air traffic management (see Part II, Section 1, Chapter 1).

4.1.2 Frequently, pre-planned flight operations that re-occur with identical basic features such as aircraft identification, departure aerodrome, route and destination, etc., may be exempted from the requirement to submit a separate flight plan for each individual flight. Regional procedures for these repetitive flights have been in existence for a number of years and permit such flight plans to be submitted by operators for retention and repetitive use by ATS units.

4.1.3 Once a flight plan has become current, an exchange of ATS messages between sectors and/or centres is necessary to determine progression of the flight. The provisions concerning ATS messages are included in the PANS-RAC, Part VIII.

4.1.4 Flight data received by an air traffic control (ATC) unit in the form of individual or repetitive flight plans (RPLs), ATS messages or via radiocommunication between pilots and controllers must be displayed to the controller. Normally this is done on flight progress strips, or in automated systems on radar data displays and/or electronic data displays.

4.1.5 While simultaneous transmission of flight plan data is required for planning purposes, the progressive transmission of current flight plan data appears to allow more flexibility and thus reduces the work level on the ATC unit in particular in cases involving required changes to flight plans. Therefore planning of ATS facilities should take account of the required level of communication channels and processing facilities to allow for the progressive transmission of flight plan data between adjacent ACCs.

4.2 USE OF FLIGHT PLANS

4.2.1 Submission and acceptance of flight plans

4.2.1.1 To obtain an ATC service, it is necessary for the pilot to submit a flight plan. Except when RPL procedures are applied, a completed flight plan form is normally submitted by the pilot or his designated representative to the ATS reporting office at the departure aerodrome. Accuracy is required in the completion of the flight plan form since it is the basic document by which the pilot's intentions are made known to all ATS units along the route of the flight.

4.2.1.2 The ATS unit receiving a flight plan or changes thereto is required to check the data and to take the necessary action in case of errors. Currently, there is a need to improve the integrity of such data, since a high percentage of the errors in flight data are man-made and should be eliminated during the initial input of the data and before transmission to other ATS units.

4.2.1.2.1 A means for achieving a significant reduction in human-originated errors is the use of micro-processor technology in the form of intelligent terminals to replace the commonly used teletypewriter as an input device. A dialogue capability between the intelligent terminals and the operator facilitates the input of ATS messages and the correction of errors detected by the programmed terminal, prior to final entry into the aeronautical fixed telecom-

munication network (AFTN). Computer-assisted ATS message preparation results in a further considerable reduction in human-originated errors.

4.2.1.3 Further automation (i.e. automatic message generation and transfer and automatic processing of ATS messages) offers the additional benefit of timely, highly reliable flight data for ATC and would thus enhance safety in civil aviation.

4.3 REPETITIVE FLIGHT PLANS

4.3.1 General

4.3.1.1 RPLs are flight plans related to frequently recurring pre-planned flight operations with identical characteristics and which may be submitted by operators for retention and repetitive use by ATS units for a specified period of time, thus eliminating the need for an operator to file a flight plan each time one of these flights is operated.

4.3.1.2 Apart from the reductions in the number of flight plans required to be filed, the use of RPLs offers a number of other advantages, such as:

- a) reduction of errors due to poor handwriting or incorrect completion of flight plan forms and errors of transmission;
- b) an appreciable reduction in the work of operators, ATS units and aeronautical telecommunications personnel;
- c) an appreciable reduction in the load on communication channels used between ATS units and between operators and such units;
- d) earlier availability of flight plan data, which permits preparation of flight progress strips in good time and the early display of flight plan data which may facilitate advance planning of the air traffic flow.

4.3.1.3 The procedures used for RPLs are capable of application regardless of whether automatic data processing equipment is available to ATS units or whether flight plan data are handled manually. Detailed refinements concerning the acquisition, storage, processing and transfer of data may be necessary, however, to accommodate local or national requirements.

4.3.2 Basic requirements

4.3.2.1 The use of RPLs should take account of the following requirements:

- a) specification of the frequency of flight operations concerned;
- b) specification of the assurance that flight plan data provided in the RPL are stable;
- c) the capability of ATS to store and activate RPLs;
- d) the development of detailed methods for the submission, change and cancellation of RPLs;
- e) appropriate agreements between ATS and operators concerned for implementation of the RPL system.

4.3.3 Implementation

4.3.3.1 Prior to introducing a system of RPLs, consultations with operators likely to participate are necessary to determine the optimum arrangements.

4.3.3.2 The use of RPLs can initially be established most easily for flights operating within a single FIR or a single State. The system may also be established for flights across international boundaries; however, such arrangements require the establishment of bilateral or multilateral agreements between States. Multilateral agreements involving a large number of States may take the form of regional air navigation agreements.

4.3.3.3 When implementing the use of RPLs, States should publish their intentions in relevant aeronautical information publications well in advance and provide all necessary details, such as the area of application, the procedures to be applied for the submission of data, the agency to which relevant flight data are to be sent by operators and specifications for additional data, if any.

4.3.3.4 States should notify ICAO Regional Offices when implementing the RPL system. Regional Offices concerned can then publish summaries showing the status of implementation within the region concerned.

4.3.4 Operation

4.3.4.1 When determined by the appropriate authority(ies), the use of RPLs should be based on the basic requirements as shown in 4.3.2. The detailed procedures required to make such use successful are to be determined in accordance with the data-handling capability of the ATS units concerned. Basic actions required in this respect are:

- a) the operator transmits RPLs, in standard format, together with an indication of the effective periods of operation for those flights meeting the agreed regularity and frequency requirements to all offices/ATS units concerned. The RPL should reach all addressees at a

specified time prior to the effective date of the first flight covered by any of the RPLs. The required lead time for submission should be part of the agreements with operators and should be published in aeronautical information publications;

- b) the RPLs are stored by each ATS unit concerned in a manner that will ensure that the plans are systematically activated on the appropriate day of operation and in the order of the estimated times of entry into the unit's area of responsibility. Activation of the flight plans is to be accomplished so that the data are presented to the controller in appropriate form and in sufficient time for his analysis and action;
- c) provisions should be made to permit an up-date of the RPL data files whenever one or more of the following events occur:
 - 1) permanent changes to all flights;
 - 2) temporary and incidental changes to individual flights;
 - 3) cancellations of all or specific flights;
 - 4) additions to the number of flights;
 - 5) submission of completely revised lists when this appears appropriate in view of extensive changes.

4.3.4.2 Depending on the agreed administrative arrangement, the RPL should be submitted to:

- a) a designated office in a region or in each State or each FIR concerned, which will select and forward relevant flight plan data to ATS units concerned; or
- b) each area control centre (ACC) or FIC concerned with the repetitive flights; or
- c) the ATS reporting office responsible for the departure aerodrome, which will select and forward relevant flight plan data to other ATS units concerned.

The objective of such agreements is to have a single office designated for the largest possible area, consistent with identical operational needs, which will forward relevant flight plan data to all ATS units concerned. Every effort should be made to establish such an office in areas where RPLs are utilized.

4.3.4.3 Operators should submit flight plan data for all eligible series of flights, in accordance with the procedures in the PANS-RAC, Part II, or as indicated in 4.3.4.4 below. Acknowledgement of receipt of RPL data by the receiving ATS office is advisable, at least during the initial phase of use of RPLs.

4.3.4.4 Submission of RPLs by media suitable for electronic data processing may be implemented in accordance with procedures agreed upon by the appropriate ATS

authorities and the operators. When this method of submission is utilized, strict specifications must be established and adhered to. A specific procedure for submission of RPLs on magnetic tape has been developed in the European region. Details of the procedure can be obtained from any ICAO Regional Office.

4.3.4.5 Procedures for handling RPLs by ATS units are prescribed in the PANS-RAC, Part II.

4.4 METHODS OF ATS MESSAGE EXCHANGE

4.4.1 The ATS data flow is determined by three main factors: the functions to be performed, the types of data to be exchanged, and the processing facilities at the ATS units. However, the availability of adequate communications means is a prerequisite to any data exchange.

4.4.1.1 Although the submission of flight plans is primarily intended for ATC, the basic data in them can also be used for short-term flow management predictions for a period of approximately one hour ahead (tactical demand/capacity balancing) (see also Part II, Section 1, Chapter 1 — Air Traffic Management).

4.4.1.2 ATS messages are grouped into the following categories:

- a) basic flight plan messages and associated update messages;
- b) co-ordination messages;
- c) supplementary messages;
- d) control messages.

4.4.1.3 For ATC purposes, the first en-route ACC normally needs basic data approximately 30 minutes before departure. The controller at the next and successive centres will require co-ordination data with a lead time of approximately 20 minutes ahead of the traffic concerned so that each, in turn, will be able to prepare for the transfer of control.

4.4.1.4 Basic data, and their updates, should be addressed simultaneously to appropriate flow management centres, to the first ACC involved and to any other ACC along the route of the flight.

4.4.2 The flow of basic data and updates is depicted in Figure 1, in which O represents the originator of the FPL message or RPL listing. FM1 and FM2 represent two flow management centres. The first flow management centre

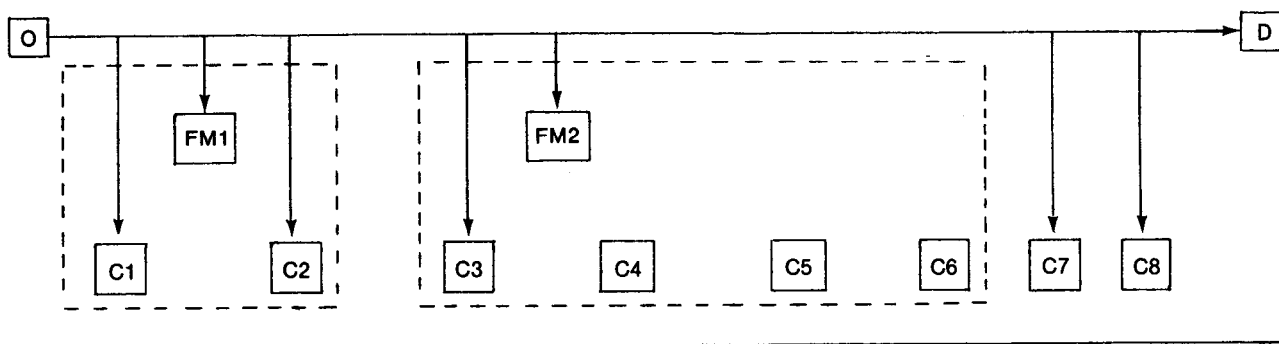

Figure 1.— Flow of basic data

serves ATS units C1 and C2, the second flow management centre serves ATS units C3, C4, C5 and C6. No flow management is applied at ATS units C7 and C8. It is assumed that several other ATS units may be involved, and the last unit is the control tower D at the destination aerodrome. ATS units C4, C5 and C6 do not require basic data and updates, since they will be able to process current flight data which they will receive as the flight progresses.

4.4.2.1 When a flight is current, progressive co-ordination is required between successive sectors and ACCs throughout the duration of the flight. Co-ordination data transferred from ACC to ACC include proposed conditions of transfer, as contained in the estimate (EST) message. These will supplement the already available (updated) basic data.

4.4.2.2 In the example described, ATS units C4, C5 and C6 have not yet received any basic data. These ACCs will receive updated basic data, together with the proposed conditions of transfer. This combination of co-ordination data and basic data is a CPL message. The flow of co-ordination data is depicted in Figure 2.

4.4.2.3 Thus it can be seen that the application of CPL messages in the co-ordination process offers certain clear advantages. The ATS units concerned receive the necessary information in time. They do not have to store basic data and update this information, since they will receive a complete set of updated basic and co-ordination data.

4.4.2.4 On the other hand, ATS units without the required processing capabilities or without adequate communication circuits still require the timely receipt of basic data. Flow management centres also require basic data at an early stage. Such units will have to store the basic data and amend them as and when updates are received.

4.5 FLIGHT DATA PRESENTATION

4.5.1 Flight progress strips

4.5.1.1 Data concerning the current progress of flights provided with ATS are normally displayed on 2½ cm by 21 cm flight progress strips to facilitate the prediction and resolution of conflicts between aircraft. The strips are coded, by colour or otherwise, to indicate the general direction of flight and/or the flight rules under which the flight is operating.

4.5.1.2 Essential details concerning each flight are recorded on a flight progress strip or a series of flight progress strips depending on the type of ATS provided. For flights in control areas a separate strip is normally prepared for each displayed reporting point along the route of the flight. As a flight progresses, information on flight progress strips is amended, as necessary, according to the latest information available. A continual assessment is

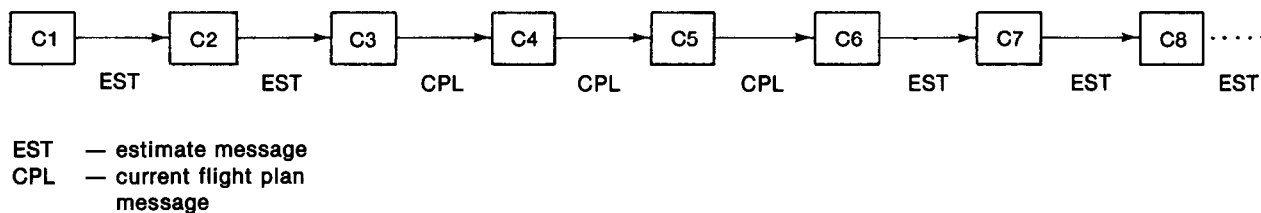

Figure 2.— Flow of co-ordination data

constantly being made of the relationship of known flights to each other.

4.5.2 Operation of the flight progress system

4.5.2.1 Introduction

4.5.2.1.1 Only such data as are required for the efficient operation of a particular operating position need be recorded on flight progress strips. However, it must be borne in mind that, in addition to being used as an aide memoire, the recorded information should be sufficient to enable a change of watch to be effected with the minimum of briefing or for a traffic situation to be reconstructed in the correct sequence of events, if required.

4.5.2.1.2 When surveillance radar is in use, the procedural controller need record only those flight details necessary to maintain an appreciation of the traffic flow and to permit procedural control to be introduced in the event of radar failure. Such procedures are usually outlined in local operating memoranda.

4.5.2.2 Preparation of strips

4.5.2.2.1 Flight progress strips should be prepared for use on receipt of a flight plan, or other advice that the flight is airborne or about to become airborne. Partial prep-

aration of strips may be carried out at an earlier time when information is available from RPLs or other sources as airline schedules, flight notifications, etc. The points at which aircraft will enter, leave, or cross controlled airspace should be noted and en-route strips prepared by reference to relevant en-route reporting points. Sufficient strips relating to each flight should be prepared to meet the requirements of each operating position concerned with the flight. The terms, methods and symbols used in the flight progress strip marking system are shown in Appendix A.

4.5.2.2.2 At units where two or more functions are performed at one operating position, strips should be prepared for the combined operating position only, for example, when approach control and aerodrome control are combined, the approach strip may be used for the dual purpose.

4.5.2.3 Use of strips

Strips displayed on the active bays of the flight progress board should be placed above the bay designator in chronological order with the earlier time in the lower position. The strips should be retained on the board until the information contained thereon is no longer required and, in the case of controlled flights, until there is no longer any possibility of conflict with other traffic. Strips no longer required should be removed from the board and filed.

— — — — —

Appendix A

Terms, Methods and Symbols used in Relation to the Flight Progress Strip Marking System

1. TERMINOLOGY

1.1 The following terms are used to describe the various items involved in flight progress equipment and strip marking:

Flight progress board. A specially constructed board used for the display of flight progress strips.

Bay. A panel, or subdivision of a panel of a flight progress board, representing one or more locations.

Bay designator. A plaque used to identify a bay. Normally movable and engraved with the coded name(s) of the location(s) which the bay represents.

Holding bay. A bay for storing prepared or partially prepared flight progress strips.

Suspense bay. A bay for storing prepared flight progress strips which will be required within the ensuing 30 minutes.

Active bay. Any bay used for the display of flight progress strips relating to flights operating in or about to operate in the area of responsibility.

Flight progress strips. A specially printed strip of card on which is recorded essential information relevant to the flight of an aircraft.

Strip holder. A mobile piece of equipment into which a flight progress strip is fitted for display on the flight progress board.

Departure strip. A flight progress strip used to display essential details of a departing flight.

Arrival strip. A flight progress strip used to display essential details of an arriving flight.

En-route strip. A flight progress strip used to display essential details of a flight at each displayed reporting point over which the flight will pass.

Entry strip. The en-route strip used at the first reporting point on the route of the flight within the area of responsibility.

Exit (or Transfer) strip. The en-route strip used at the last reporting point on the route of the flight within the area of responsibility.

Blocking strip. A flight progress strip positioned in a reporting point bay to indicate that a clearance or clearance approval has been issued to an aircraft departing from an aerodrome in an adjacent sector and which will be crossing the particular entry reporting point within 15 minutes of departure.

Radar strip. A flight progress strip used in radar control to display essential details of a flight receiving a radar control service.

IFR strip. A flight progress strip used to display essential details of a flight operating under IFR outside controlled airspace.

Box. A subdivision of a flight progress strip within which specified details are recorded.

2. METHODS USED IN MARKING STRIP

2.1 Black ink pens, either ball point or felt/nylon tipped, should be used for recording entries.

2.2 All handwriting should be neat, clear and concise.

2.3 Letters should be written in printed capitals.

2.4 Arabic numerals should be used in recording figures and time should be recorded in four digits (hours and minutes).

2.5 Correction of errors should be made by crossing through the incorrect data with double horizontal lines and inserting the correct data in the same box. Erasures must not be made.

2.6 Updating of data on the strip should be achieved by crossing through the out-of-date information with a single line and inserting the new data within the same box.

2.7 Uncancelled data displayed on a flight progress strip should be assumed to have been verified as correct. No additional ticks or other markings shall be used to indicate that the data have been checked.

2.8 Levels should be recorded by using two or three figures representing hundreds of feet or metres of altitude or flight level as appropriate.

2.9 Planned cruising levels should be recorded in the appropriate box of the strip and, if approved when the clearance is issued, remain untouched.

2.10 Level changes should be tabulated downwards in order of occurrence. Levels to be checked in climb or descent may be shown separately alongside the climb/descent symbol.

2.11 Estimated times of arrival (ETAs) should be tabulated downwards in order of occurrence.

2.12 Any item of an aircraft report which is not in accordance with a previously issued clearance or approval, should be recorded alongside the correct data and circled. Any such information not corresponding to that recorded should immediately be checked with the aircraft.

Aircraft has reported at wrong level (indicated in circle)

e.g. 80

Alternative instructions

(. . .)

Below . . . ft

— . . .

. . . ft or below

. . . —

Climb

↑

Climb co-ordinated

↑↻

Climb 1 000 ft below (aircraft)

↑(a/c call sign)
1

Climb when instructed by radar

↑R

Cruise climb

↑CC

Cleared to cross airways/ADR

X

Clearance expires at (time)

CE

Co-ordination effected

↔

Current weather

WX

Delay not determined

Z

Descend

↓

Descent co-ordinated

↓↻

Expected approach time

EAT

ILS

I

Joining flight

⇒

Leaving controlled airspace

△

Maintain

↔

No delay expected

Λ

Outer marker

OM

3. SYMBOLS USED ON STRIPS

3.1 Examples of symbols used for flight progress strip marking in one State (United Kingdom) are as follows:

Above . . . ft + . . .

. . . ft or above . . . +

After passing /

Aircraft given time check T

Aircraft given appropriate altimeter setting Q

Aircraft instructed to hold H

Overhead	QFG	Report leaving (level)	RL
Overflight	V	Report passing (level)	RP
Radar	R	Report reaching (level)	RR
Radar vectoring for a visual approach	R/V	Request flight level change en route	RLCE
Radar vectoring for ILS approach	R/I	Restrictions written below this line	_____
Release not before	_____ (time)	Reporting point	F
Release not before	— R(time) (for use with data transfer systems)	Surveillance radar approach	SRA
Release subject to (call sign or title, aircraft or agency)	RS	This information has been passed and acknowledged.	✓

AIR TRAFFIC SERVICES PLANNING MANUAL

PART II

SECTION 4. METHODS OF APPLICATION EMPLOYED BY ATS

SECTION 4
METHODS OF APPLICATION EMPLOYED BY ATS

Contents

	<i>Page</i>		<i>Page</i>
Chapter 1. ATS in Oceanic Airspace	II-4-1-1	Chapter 3. Helicopter Operations	II-4-3-1
1.1 Introduction	II-4-1-1	3.1 Introduction	II-4-3-1
1.2 Flight planning	II-4-1-1	3.2 Performance characteristics	II-4-3-1
1.3 Navigation	II-4-1-1	3.3 ATS considerations	II-4-3-1
1.4 Air-ground communication	II-4-1-1	3.4 Operations over the high seas	II-4-3-2
1.5 Position reporting	II-4-1-1		
1.6 ATC clearances	II-4-1-2		
Chapter 2. Mixed IFR/VFR Operations	II-4-2-1	Chapter 4. Supersonic Transport (SST)	
		Aircraft Operations	II-4-4-1
2.1 Introduction	II-4-2-1	4.1 Introduction	II-4-4-1
2.2 Application of ATS	II-4-2-1	4.2 Planning of ATS	II-4-4-1
2.3 Provisions concerning VFR flights and related problems	II-4-2-2	4.3 Communication requirements	II-4-4-2
		4.4 Sonic boom aspects	II-4-4-2

Chapter 1

ATS in Oceanic Airspace

1.1 INTRODUCTION

The provision of air traffic services (ATS) in oceanic airspace differs in many aspects from that provided over land areas. Oceanic flights are conducted in airspace where no sovereign rights are exercised and where normally, in that airspace, more than one State is concerned with the provision of ATS. Therefore the planning of ATS for such operations is basically a matter of international concern. The development and implementation of the ICAO air navigation plans and the provision of ATS for such areas is entrusted by ICAO to designated States based on regional air navigation agreements.

1.2 FLIGHT PLANNING

1.2.1 Flight planning plays an important role in operations over oceanic airspace. Theoretically, the flight path from departure aerodrome to destination, along a great circle, would give the minimum distance track. However, wind speeds and directions and other meteorological aspects such as temperature, areas of clear air turbulence, etc., affect flight times and therefore the optimum flight paths vary considerably from day to day.

1.2.2 Other constraints, such as provisions applicable in domestic airspace on either side of the oceanic ATS route network, airspace restrictions and/or reservations etc. may also affect flight planning. Additionally, the free choice of the desired flight path may be restricted by the need to maintain a particular flight level, Mach number or a specific track in an organized track system.

1.3 NAVIGATION

Navigation over most of the oceanic area is based on long-range navigational aids such as OMEGA or

LORAN-C or INS. The navigation performance requirements for a specific aircraft or flight is decided by the State of Registry or the State of the Operator as appropriate. The navigation capability of aircraft involved may differ considerably, and therefore the agreed horizontal separation minima for application in oceanic airspace are quite substantial compared to those applied in continental areas. In the North Atlantic (NAT) region a portion of the airspace has been defined as airspace wherein minimum navigation performance specifications (MNPS) apply and this has made it possible to considerably reduce the lateral separation minima in this airspace compared to those used in oceanic airspace not so designated (see also Part II, Section 2, Chapter 4).

1.4 AIR-GROUND COMMUNICATION

Most oceanic air-ground communications are conducted on frequencies in the high frequency (HF) band. At present pilots normally communicate on HF with the oceanic area control centres (OAC) via ground communication stations which are not necessarily co-located with the OAC and messages must therefore be relayed, mostly by teletype, between the ground station and the relevant OAC. Where this method of air-ground communication is employed it is inevitable that all reports, clearances and acknowledgements exchanged between pilots and controllers are subject to a certain delay. Sufficient lead time must therefore be allowed when issuing air traffic control (ATC) clearances or when expecting position reports over oceanic airspace. However, further improvement to the HF communication techniques, based on the use of satellites, may permit direct pilot-controller communications at a later date.

1.5 POSITION REPORTING

When flying outside an established ATS route network, position reports are normally expressed in latitude and

longitude or by using the specific name codes of assigned or designated reporting points. Position reports are given at intervals of 5, 10 or 20 degrees latitude or longitude, as regionally agreed, to provide information at approximately hourly intervals. This relatively low rate of position updates is one of the reasons for the comparatively large horizontal separation minima applied in oceanic airspace.

1.6 ATC CLEARANCES

1.6.1 The fuel cost is a dominant part of the total cost of flight operations and is especially significant for long-distance flights. ATC can assist in fuel conservation by imposing constraints on intended flight operations only when the constraint is essential in view of the over-all

traffic situation. It should also be kept in mind that the pilot's request for a change of his current flight plan (CPL) is normally a result of a change in the operational factors affecting the efficiency of his flight. Such a request should therefore be met if at all possible.

1.6.2 Changes to the planned flight may also be initiated by the controller for reasons of separation. There are basically four possibilities for such a deviation: change in flight level, track, speed or time of entry into the oceanic airspace. The alternative, selected by the controller concerned, in a specific situation should not only be based on a sound knowledge of the flight planning techniques used by operators but also of the factors affecting the efficiency of flight operations. Facility management should therefore cover this subject during training and familiarization of controllers required to work in oceanic area control centres (ACCs).

Chapter 2

Mixed IFR/VFR Operations

2.1 INTRODUCTION

2.1.1 Annex 2 contains general rules applicable to both instrument flight rules (IFR) and visual flight rules (VFR) flights, including those related to the avoidance of collisions, and the specific VFR dealing with the conditions concerning visibility and distance from clouds. Annex 2 also contains provisions regarding air traffic services (ATS) to VFR flights at controlled aerodromes, operated as special VFR flights, or in controlled airspace (instrument/visual).

2.1.2 Annex 11 contains provisions concerning airspace organization and ATS and makes provisions for controlled airspace, without any restricting clause, as well as for controlled airspace with restrictions as follows:

- a) controlled airspace (instrument restricted);
- b) controlled airspace (instrument/visual);
- c) controlled airspace (visual exempted).

2.1.3 In controlled airspace without any restricting clause the provisions concerning VFR flights are unspecified. Controlled airspace (instrument restricted) is reserved for IFR flights only. In controlled airspace (instrument/visual) both IFR and VFR flights are controlled by air traffic control (ATC), and in controlled airspace (visual exempted) both IFR and VFR flights are permitted, but VFR flights are not subject to control.

2.1.4 ATC provides separation between controlled IFR flights and controlled VFR flights, including special VFR flights; between special VFR flights; and, when so prescribed, between controlled VFR flights in controlled airspace (instrument/visual). In controlled airspace (visual exempted) VFR flights are provided with flight information service, but there exists no specific requirement on ATS to provide such flights with information on collision hazards based on the understanding that pilots will be able to avoid collisions with other aircraft by applying the "see and be seen" concept.

2.2 APPLICATION OF ATS

2.2.1 The application of the existing provisions concerning VFR flights in a mixed IFR/VFR environment differs considerably amongst and within States, depending mainly on the traffic volume, composition and complexity. In many States, VFR operations create no specific problems and the application of the basic ICAO provisions has been found to be sufficient to meet the required level of safety and service. Where this situation exists, it is mainly due to the relatively small concentrations of mixed IFR/VFR operations and the generally favourable meteorological conditions. In some States, including those where large numbers of general aviation flights are conducted, it has also been found that the authorization to conduct VFR flights at night has not caused any significant problems.

2.2.2 As traffic increases at and around an aerodrome there may be a need to introduce specific provisions for VFR operations. As a first step, the requirement for two-way radiocommunication capability by all aircraft operating into or in the vicinity of the aerodrome concerned, should be considered. This requirement will provide the ATS with the possibility of improving its service to both VFR and IFR flights concerned.

2.2.3 Where traffic density and prevailing meteorological conditions warrant a further tightening of ATS provisions, it may be necessary to segregate VFR flights from IFR arrivals and departures. The introduction of VFR corridors and/or VFR routes, entry and exit points and holding fixes should then be considered. As an alternative or as a complement to the above, it may also be advisable to upgrade the airspace around an aerodrome from controlled airspace (visual exempted) to controlled airspace (instrument/visual) in order to enable ATS to separate both IFR and VFR flights by subjecting the latter to air traffic control procedures and clearances.

2.2.4 As a consequence of airspace upgrading, it may also be necessary to impose additional pilot qualifications and

specific requirements regarding the carriage of navigation equipment in aircraft for operation in that airspace. Additional pilot qualifications might include a specific level of experience additional to that required for the issue of a private pilot's licence or a navigation capability, while the requirement for the carriage of adequate airborne equipment may specify the installation of VHF omnidirectional radio range (VOR) receivers, and in some cases even secondary surveillance radar (SSR) transponders.

2.2.5 At aerodromes with a significant number of IFR operations, traffic schedules for VFR flights during peak traffic hours may have to be considered. Alternatively, specific types of VFR operations, e.g. pilot training exercises, etc., may have to be re-scheduled, restricted or even curtailed during specified periods.

2.2.6 Where the density of the en-route IFR traffic warrants, the establishment of controlled airspace (instrument/visual) or (instrument restricted) should be considered, taking into account the likely risk of collisions on one hand, and on the other, the consequences of restrictions imposed on VFR operations in such types of airspace.

2.3 PROVISIONS CONCERNING VFR FLIGHTS AND RELATED PROBLEMS

2.3.1 In recent years, aircraft have become larger and faster and the speed and altitude capability of light aircraft has increased considerably. In addition to the existing requirements of the various types of aircraft engaged in VFR operations, new types of activities, such as hang gliding, power-driven hang gliding and sports parachuting, have been introduced and must now be considered in relation to the provisions regarding VFR operations. There is, therefore, a growing awareness that the provisions concerning VFR operations have not kept pace with aviation developments in general, especially as regards aircraft performance and traffic composition and care should be taken to ensure that any measures adopted should reflect the latest ICAO provisions.

2.3.2 A number of States, handling a considerable number of aircraft operations with a large mixture of IFR and VFR flights and which experience a wide variety of weather conditions, have found it necessary to introduce provisions supplementary to those of ICAO in order to restore an appropriate level of safety in their areas. As existing ICAO provisions give little guidance in this respect, the specific national provisions, developed

individually to cater for specific circumstances, tend to vary from State to State, thus creating difficulties for pilots engaged in international VFR operations.

2.3.3 Military flight operations, which in the past were mostly performed in the upper airspace, now tend to be conducted at low levels. This has resulted in an increased demand on that part of the airspace where the majority of VFR flights are normally operating. In addition, a comparatively large number of military operations, such as high speed, low level flights, are performed in such a way that they cannot be classified as either VFR or IFR flights. In areas where the availability of airspace is limited and the traffic is dense, additional problems are created which cannot easily be solved by segregation only, but may also require procedural arrangements and/or creation of special airspace reservations. In both cases, special provisions regarding the conduct of operations and publication of the relevant arrangements, possibly in the form of charts, is one important aspect that must be considered.

2.3.4 Some States have found it necessary when dealing with the procedural aspects associated with the mix of VFR and IFR traffic to develop new airspace additional to that contained in the ICAO provisions wherein aircraft operating in accordance with VFR are subject to additional rules. These rules are applied to those areas where the density of traffic warrants such additional rules but where the imposition of control of VFR traffic is not justified.

2.3.5 There are also indications that several States see a need for providing information on collision hazards to aircraft operating outside of controlled airspace in which case information, which is at present available only to IFR aircraft, is provided also to VFR flights in specified portions of that uncontrolled airspace. Experiments with an elaborate flight information service provided to helicopters operating in the North Sea area are presently underway. One State is in the process of introducing similar provisions on a permanent basis.

2.3.6 In the United States, services similar to those in 2.3.5 have been in use for some time, with participation by pilots on a voluntary basis. It is worth noting that approximately 90 per cent of the pilots concerned use this service.

2.3.7 In the United Kingdom, a service known as "lower airspace radar service (LARS)" is applied which provides advisory service to participating aircraft, based on information derived from radar facilities established to serve military aerodromes. The advice given is limited to known traffic only and avoidance instructions are not given unless requested by the pilot. The airspace wherein

this service is available covers a sizable portion of the total United Kingdom airspace.

2.3.8 An experiment with a new type of airspace, which is between controlled airspace (visual exempted) and controlled airspace (instrument/visual), and associated

provisions regarding service to aircraft in this airspace, is being conducted at Lyon (France). The Federal Republic of Germany provides an "improved" flight information service to VFR aircraft in controlled airspace below FL 100 and outside those portions of the airspace wherein VFR flights must be conducted as controlled VFR flights.

Chapter 3

Helicopter Operations

3.1 INTRODUCTION

3.1.1 Helicopter operations have increased significantly in recent years to a point where they are now, in certain areas, so numerous as to become a problem from an air traffic services (ATS) point of view, a problem that will be accentuated in the years ahead. It should also be noted that the instrument flight rules (IFR) operations by helicopters are a comparatively new event in the ATS system, and that helicopters have now entered an environment in which the air traffic control (ATC) procedures, developed and refined over many years to cater for the needs of fixed-wing aircraft, are not necessarily suitable for the unique characteristics of rotary-wing aircraft. One State (United States) expects that, by the end of the 1980s, at least 50 per cent or about 7 000 of its combined business/corporate type helicopters will have an IFR capability. These trends are particularly significant from an ATC viewpoint and underline the need to be prepared for adjustments in those ATC systems where the number of helicopters served is already considerable or where it can be foreseen that helicopters will become a significant part of the over-all air traffic.

3.1.2 As a result of the growing technical sophistication of helicopters, advances in their operational capabilities, and the increasingly international character of helicopter operations, Standards and Recommended Practices (SARPs) and guidance material on helicopters similar in scope to those currently provided for aeroplanes are being developed. States developing regulations concerning helicopters should ensure that they are in possession of the most recently introduced ICAO material on this rapidly developing subject.

3.2 PERFORMANCE CHARACTERISTICS

3.2.1 Helicopters have a number of unique capabilities that have an important influence on ATC operations. Some of these characteristics have a marked influence on the efficient mixing of traffic. For example, on final

approach, the generally slower speeds of helicopters prevent their orderly integration with high speed aircraft and result in lower runway capacity. However, the low speed and good manoeuvrability of the helicopter enable it to safely maintain visual reference to the ground under worse weather conditions than is possible for aeroplanes.

3.2.2 Other characteristics provide measures of flexibility that assist in ATC maintaining an efficient traffic flow of helicopters. One example is the ability of the helicopter to hover-taxi. After making an approach to a minimum descent altitude, or decision height, the helicopter can proceed directly to a helipad and therefore requires zero runway occupancy time. Nevertheless, in general, it is desirable to segregate helicopters from aeroplanes in the terminal control area (TMA) and/or control zone, whenever it is possible to do so; for the en-route portion of operations, it appears that it will be desirable to establish separate helicopter routings.

3.2.3 Helicopters have the potential ability to navigate to and land on virtually any flat surface with an area not much larger than the helicopter's rotor diameter. As a result, States may eventually provide navigation, communications and surveillance services to many places where these services were not previously required. The requirements of offshore helicopter operators have already indicated the need for these services beyond the coverage now provided by existing shore-based facilities.

3.2.4 In the majority of cases, helicopters are operated at levels up to 1 200 m (4 000 ft) and in accordance with both visual flight rules (VFR) and IFR. Outside controlled airspace, helicopters are permitted to operate in accordance with VFR in conditions of visibility which are very much reduced in comparison with those required by aeroplanes.

3.3 ATS CONSIDERATIONS

3.3.1 The major problems created for ATS stem from the fact that a large number of helicopter flights are conducted at low level beyond very high frequency (VHF) communi-

cations coverage and high frequency (HF) coverage at those levels is not provided. In some regions of the world, and especially over the high seas during off-shore air operations, it is very difficult or even impossible to provide conventional traffic control and separation because of inadequate air-ground communications. In some areas, vertical spacing between helicopters has been reduced to 150 m (500 ft), thus making the timely communication of accurate altimeter settings especially crucial to safety.

3.3.2 VHF communications, navigation by means of VHF omni-directional range (VOR)/distance measuring equipment (DME), and radar surveillance are all subject to line-of-sight propagation limitations. As a result, their usable range at low levels is relatively short. Consequently, helicopters operating in their preferred environment, particularly in offshore and remote areas, are often outside the coverage of these facilities.

3.3.3 Additionally, the ATC system is not well adapted to deal with random-route operations. In a radar environment, for example, one of the basic ATC problems is the controller's difficulty in visualizing flight routes between waypoints which are not shown on his video map. There exist some 2 400 offshore helicopter platforms in the Gulf of Mexico, any one of which could become a point of origin or destination. Trying to portray all these possible waypoints on a display all the time would simply create a confusing situation to the controller.

3.3.4 Various methods of providing continuous, static-free voice communications between controllers and helicopter pilots operating outside of normal ATC air-ground communications coverage are being investigated at present. Possible solutions include the use of troposcatter VHF links between an ATC unit and repeater stations, the latter having direct VHF links between the repeater stations and helicopters. Other solutions include the use of microwave relay between ATC facilities through repeater stations, and even air-to-air relay of communications in some instances. It is expected that long-term solutions to static-free over-the-horizon communications, navigation and surveillance will involve the use of satellite technology.

3.3.5 The volume of traffic and its composition may justify the establishment of different instrument approach and departure routes for conventional aircraft and helicopters to reduce the ATC workload which otherwise would be caused by the difference in speed between the two types of aircraft. However, where helicopters must be

merged with conventional aircraft into a common instrument approach path, the path should be kept as short as practicable to minimize the effects on capacity resulting from differences in approach speeds.

3.3.6 Another possibility to segregate helicopter operations in a TMA or a control zone would be the establishment of uncontrolled corridors to enable uncontrolled VFR traffic, including helicopters, to have access through controlled airspace or to aerodromes. Even for the en-route phase of helicopter operations, the establishment of discrete ATS routes offers a method to segregate IFR helicopters from other traffic. When ATS routes are established for helicopters alone, however, these routes should be designated with the basic designator K ("KOPTER") in accordance with Annex 11, Appendix 1.

3.4 OPERATIONS OVER THE HIGH SEAS

3.4.1 Since the arrangements required for the provision of ATS, as well as those for other types of services (e.g. meteorological and search and rescue services), for helicopter operations over the high seas depend almost exclusively on the availability of means for direct and reliable air-ground communications, it is important that those concerned with systems planning approach, i.e. operators, agencies providing air navigation services and other agencies, be consulted and contribute to the solution of the specific problems related to helicopter operations over the high seas.

3.4.2 Helicopter operations over the high seas are in many cases not a matter of concern to one State only, but often concern a group of States which share the responsibility for the provision of air navigation services (as a result of regional air navigation agreements). One such example is the provisions for helicopter operations in the North Sea where a number of States are involved with the oil exploration projects. Guidance material, which has been developed from practical experience with helicopter operations in the North Sea by Norway, the United Kingdom and the Kingdom of the Netherlands is at present available, as is material developed by the United States and Mexico concerning operations in the Gulf of Mexico. The guidance material covers not only provisions related to ATS but also other provisions, such as altimeter setting procedures and approach and landing aids and can be obtained from any ICAO Regional Office.

Chapter 4

Supersonic Transport (SST) Aircraft Operations

4.1 INTRODUCTION

The results of initial work, performed within ICAO, is published in Circular 126 — *Guidance Material on SST Aircraft Operations* (1975). Practical experience has since been gained in the North Atlantic (NAT) region where SST operations are taking place on a routine basis. This chapter summarizes aspects on SST operations related to air traffic services (ATS) planning which are described in detail in Circular 126 and in national documents of those States directly concerned with such operations.

4.2 PLANNING OF ATS

4.2.1 The ideal flight profile for optimum economic operation of SST aircraft should commence with an uninterrupted climb to supersonic speed, followed by an uninterrupted descent to destination along the most direct route. The flight profile covers the following phases of flight:

- a) subsonic climb;
- b) transonic acceleration climb;
- c) supersonic climb;
- d) cruise climb;
- e) transonic deceleration and descent;
- f) subsonic descent.

4.2.2 The ideal flight profile will often be impossible to arrange because of problems caused by the sonic boom and because of the presence of other aircraft in the same general area where SST aircraft operate.

4.2.3 The high rate of climb potential should be exploited whenever possible, and if necessary by the use of discrete climb paths, to avoid conflict with subsonic traffic. If it becomes necessary to interrupt the subsonic climb, the relevant clearance should be issued not later than when the SST is about 1 500 m (5 000 ft) below the level at which it is required to level off. Initial optimum subsonic cruise

conditions will be about Mach 0.9 to 0.95 in the height band between flight level (FL) 250 and FL 360 (depending on the aircraft type, weight and ambient temperature).

4.2.4 The transonic acceleration phase should, whenever possible, immediately follow the subsonic climb phase. The aircraft should not be required to turn or to interrupt the climb in this phase and its route should be free from crossing traffic.

4.2.5 Longitudinal separation between successive SST flights during supersonic cruise should, whenever possible, be achieved by spacing the aircraft concerned while they are still operating subsonically, i.e. prior to the start of transonic acceleration.

4.2.6 The supersonic climb path should be as straight as possible and the climb should be free from interruption. The preferred supersonic cruise will be conducted as a cruise-climb between approximately FL 450 and FL 650. Within this layer the actual vertical position of an SST aircraft varies for each flight depending upon the route distance, aircraft type, weight, ground speed and ambient temperature. Necessary deviations from its optimum cruise climb path should, therefore, preferably be made in the lateral plane. Any turns made while flying supersonically will require a low rate of turn and a large radius.

4.2.7 Where supersonic cruise-climb is not possible, a stepped cruise is the next preferred operating method. Steps should be arranged as close as possible to the optimum cruise-climb profile and a departure of more than 1 200 m (4 000 ft) from the optimum is most undesirable from a fuel economy viewpoint.

4.2.8 Level supersonic cruise is suitable only for shorter distances and should commence at the next appropriate flight level to that adopted for cruise-climb. As the flight continues, level cruise will progressively deviate from the optimum flight profile. The supersonic cruise should, whenever possible, be free from crossing traffic. Where it becomes necessary to resolve crossing traffic problems, the cruise-climb may be interrupted to achieve vertical separation. During supersonic cruise, the SST will normally

create sonic booms along the surface under its flight path, therefore this should be taken into account when planning SST routes.

4.2.9 Clearance for deceleration/descent should be given to the pilot sufficiently in advance in order for him to be able to plan for and comply with it. The aircraft should not be required to interrupt the descent from the point at which preparations for descent are commenced to a level in the supersonic descent appropriate to stabilized cruise at the descent speed. Consequently, the descent clearance given prior to deceleration should remain unmodified, at least to the point where cruise is stabilized. The clearance for descent should preferably cover the entire descent profile, down to subsonic level, without interruption. The descent will normally not produce a focused sonic boom unless the normal descent profile is altered or a turn is made.

4.2.10 The SST aircraft are fuel sensitive at low speeds and low holding levels and it will be preferable to absorb anticipated terminal delays en route by descending early from supersonic cruise and thereafter cruising to destination at lower speeds (normally subsonic) and flight levels. The subsonic descent and approach will be substantially the same as for other subsonic traffic except that, if required, holding should be performed at higher speeds and levels (280 kt, at FL 150 and above).

4.2.11 From the above it is evident that the SST aircraft is very sensitive to any deviation from the optimum flight path. The economic operation of the aircraft, therefore, depends to a great extent on the airspace organization and the understanding and judgement of the controller.

4.3 COMMUNICATION REQUIREMENTS

4.3.1 There is a general need to reduce the message transit time of pre-flight MET information and ATC clearances for SST aircraft. In-flight clearance procedures may also require improved point-to-point communications.

4.3.2 There is no requirement for improved short-range very high frequency (VHF) communications facilities, but there is a requirement for rapid and reliable communications extending to about 500 NM from destination terminal control areas (TMAs). If sonic boom regulations prohibit overland supersonic flight, the range requirement should cover the distance from coast lines to the TMA concerned along the route flown. This requirement is necessary to provide information to the pilot on which to

base his decisions sufficiently in advance of the planned start of descent. Where necessary, this range will also cover the requirement for traffic separation after a delayed transonic acceleration. In all cases, designated operational service height, required for VHF/ultra-high frequency (UHF) communications facilities used by SST, should be 20 000 m (66 000 ft).

4.3.3 In view of the much higher flying speeds and relative operating complexity of SST aircraft in certain flight phases, there may also be a communications requirement for automated data interchange systems.

4.4 SONIC BOOM ASPECTS

4.4.1 The sonic boom is the acoustic event caused by the shock wave generated by an aircraft flying at supersonic speed. The sonic boom will first occur during the transonic acceleration phase and will reach the ground as a high intensity focused boom, affecting a comparatively small area. Thereafter, a sonic boom carpet of lower intensity will follow the SST along its track until shortly before it again becomes subsonic. The effect of the boom across track is not constant; its effects decrease with increased angular distance. Changes in aircraft speed and/or direction can produce localized increases in the sonic boom over-pressure on the ground. Accelerations and turns affect the paths taken by successive shock waves, resulting in two or more shock waves arriving at the same point in phase with each other. This condition causes higher peak over-pressures and is known as focusing. It is important to remember that all accelerations from subsonic to supersonic speeds will produce a focused boom ahead of the point of generation. Therefore, the SST should adhere very closely to the approved acceleration routes in order not to direct sonic booms onto areas where adverse effects must be avoided.

4.4.2 In establishing supersonic routes, each State concerned by them should attempt to determine:

- a) areas to be protected from the adverse effects of sonic boom ("protected areas"); and/or
- b) corridors to be used by supersonic aircraft which cross the land area of the State concerned.

4.4.2.1 In determining SST routes, consideration will also need to be given to transonic acceleration on departure from a protected area and transonic deceleration on arrival in a protected area.

AIR TRAFFIC SERVICES PLANNING MANUAL

PART II

SECTION 5. ATS ON AND IN THE VICINITY OF AERODROMES

SECTION 5

ATS ON AND IN THE VICINITY OF AERODROMES

Contents

	<i>Page</i>		<i>Page</i>
Chapter 1. Altimeter Setting Procedures. . . .	II-5-1-1	3.2.5 Cautionaries	II-5-3-7
1.1 Introduction	II-5-1-1	3.2.6 Jet blast.	II-5-3-7
1.2 Establishment of the transition altitude.	II-5-1-1	3.3 Minimizing the effect of wake	
1.3 Determination of the transition level.	II-5-1-2	turbulence.	II-5-3-7
1.4 Determination of minimum flight levels.	II-5-1-2	3.3.1 General.	II-5-3-7
Appendix A. Method to determine the		3.3.2 The ATC dilemma	II-5-3-7
transition level which will at least coincide		3.3.3 Wake turbulence characteristics.	II-5-3-7
with the flight level corresponding to the		3.3.4 On the provision of air traffic	
transition altitude.	II-5-1-3	services (ATS)	II-5-3-9
Appendix B. Flight level graph	II-5-1-5	3.3.5 On the provision of area control	
Chapter 2. Category II and III Operations	II-5-2-1	service.	II-5-3-9
2.1 Introduction	II-5-2-1	3.3.6 On the provision of approach	
2.2 System concept	II-5-2-1	control service	II-5-3-9
2.3 Operational objectives.	II-5-2-1	3.3.7 On the provision of aerodrome	
2.4 Ground environment	II-5-2-2	control service	II-5-3-10
2.4.1 Electronic guidance system.	II-5-2-2	3.4 Vortex sensing and tracking	
2.4.2 Visual aids.	II-5-2-3	developments	II-5-3-11
2.5 Air traffic services.	II-5-2-3	Appendix A. Wake vortex avoidance systems	II-5-3-12
2.6 Aeronautical information service (AIS)	II-5-2-4	Chapter 4. Surface Movement Guidance	
2.7 Meteorology	II-5-2-4	and Control.	II-5-4-1
2.8 Ground movement control.	II-5-2-4	4.1 Introduction	II-5-4-1
Chapter 3. Wake Turbulence	II-5-3-1	4.2 Apron management service	II-5-4-1
3.1 Introduction	II-5-3-1	4.3 Surface movement radar.	II-5-4-1
3.2 Separation minima.	II-5-3-1	4.3.1 General.	II-5-4-1
3.2.1 Application of minima.	II-5-3-1	4.3.2 The role of SMR.	II-5-4-2
3.2.2 Effects on aircraft	II-5-3-2	4.3.3 Use of SMR	II-5-4-2
3.2.3 Categorization of aircraft.	II-5-3-2	4.3.4 Limitations of SMR	II-5-4-3
3.2.4 Minima related to conditions.	II-5-3-2	4.3.5 Methods of establishing SMR	
		identification.	II-5-4-3
		4.3.6 Relay of SMR position	
		identification.	II-5-4-4
		4.4 Responsibilities and functions	II-5-4-4

Chapter 1

Altimeter Setting Procedures

1.1 INTRODUCTION

1.1.1 Altimeter setting procedures are contained in the *Procedures for Air Navigation Services — Aircraft Operations* (Doc 8168, Volume I) and the *Regional Supplementary Procedures* (Doc 7030). These documents should be used by States when specifying their altimeter setting procedures including the establishment of minimum flight levels, transition altitudes and methods for the determination of transition levels.

1.1.2 The basic method used in providing adequate vertical separation between aircraft and adequate terrain clearance during all phases of flight is based on a number of basic principles. Those principles are outlined below:

- a) during flight, when at or below a fixed altitude (called the transition altitude), an aircraft is flown at altitudes determined with the aid of an altimeter set to sea level pressure (QNH) and its vertical position is expressed in terms of altitude;
- b) during flight above the transition altitude an aircraft is flown along surfaces of constant atmospheric pressure based on an altimeter setting of 1013.2 hPa (1013.2 mb). Throughout this phase of flight, the vertical position of an aircraft is expressed in terms of flight levels. Where no transition altitude has been established for the area, aircraft in the en-route phase shall be flown at a flight level;
- c) when climbing, the change in reference from altitude to flight levels is made at the transition altitude and when descending the change from flight level to altitude is made at the transition level;
- d) during any phase of a flight adequate terrain clearance may be maintained in any of several ways, depending upon the facilities available in a particular area. The recommended methods in the order of preference are:
 - 1) the use of current QNH reports from an adequate network of QNH reporting stations;
 - 2) the use of such QNH reports as are available, combined with other meteorological information

such as forecast lowest mean sea level pressure for the route or portions thereof;

- 3) where relevant current information is not available, the use of the lowest altitude values of flight levels which have been derived from climatological data;
- e) during the approach to land, terrain clearance may be determined by using the QNH altimeter setting (giving altitude) or, under specified circumstances a QFE setting (giving the height above the point to which the QFE is related, e.g. the runway threshold).

1.1.3 The method provides sufficient flexibility to permit variation in detailed procedures which may be required to account for local conditions, without deviating from the basic procedures.

1.2 ESTABLISHMENT OF THE TRANSITION ALTITUDE

1.2.1 The basic principles for the establishment of the transition altitude are contained in Doc 8168, Volume I, Part VI. Preferably a common transition altitude should be established for groups of aerodromes, aerodromes in adjacent States or for a specified area when so determined on the basis of a regional air navigation agreement.

1.2.2 The selection of a transition altitude will be governed by the following factors:

- a) the amount of traffic operating in the lower airspace;
- b) the types and performance categories of aircraft;
- c) the ratio of level flights to those climbing and descending in the same airspace;
- d) the terrain configuration;
- e) the departure and arrival procedures including noise abatement procedures;
- f) variation in the route distances involved and thus variation in cruising levels required;

- g) the rate of change in barometric pressures and the range of fluctuation along air traffic services (ATS) routes within a certain area;
- h) the infrastructure for the provision of area QNH; and
- i) the existence of other aerodromes in the vicinity.

1.3 DETERMINATION OF THE TRANSITION LEVEL

1.3.1 Approach control offices or aerodrome control towers are responsible for the establishment of the transition level to be used in the vicinity of the aerodrome(s) served. The current transition level for an aerodrome shall be available at all times and shall normally be passed to aircraft in the approach and landing clearances.

1.3.2 The means provided by a State for the determination of the transition level are not standardized on a world-wide basis. However, within the ICAO Africa-Indian Ocean (AFI) and the South American (SAM) regions a method is used for the determination of the transition level which will make it at least coincide with the flight level corresponding to the transition altitude. This method is shown in Appendix A.

1.4 DETERMINATION OF MINIMUM FLIGHT LEVELS

1.4.1 Flight levels in control areas are normally notified by States in their respective aeronautical information publication. The lowest usable flight level or levels for the whole or parts of the control area is determined by the area control centre (ACC) using the latest and most appropriate QNH altimeter setting reports. In the control area this level must always be at least 150 m (500 ft) above the established lower limit of the control area. A chart for use in converting QNH values to flight levels is shown in Appendix B.

1.4.2 Normally it is the responsibility of the pilot to ensure that an air traffic control (ATC) clearance is safe with regard to the pilots' requirements regarding terrain clearance. However, when an instrument flight rules (IFR) flight is being vectored by radar the pilot is often unable to determine his exact position and consequently his terrain clearance. States should therefore provide controllers with detailed data regarding the minimum safe altitudes for those specific areas where radar vectoring will be provided to IFR flights at low levels. Control instructions should stress the added controller's responsibility in this respect.

— — — — —

Appendix A

Method to Determine the Transition Level which will at least Coincide with the Flight Level Corresponding to the Transition Altitude

1. GENERAL METHOD

1.1 To determine the transition level for a transition layer of 150 m (500 ft), 300 m (1 000 ft), etc., it will suffice to add the figures 5, 10, etc., to the transition level shown in the appropriate column of Table 1.

1.1.1 The columns on the left show the values that can be assigned to transition altitudes and the top lines indicate the pressure ranges in hectopascals between which the QNH values of the aerodrome fluctuate. The transition level for a transition layer of at least 50 m (500 ft) appears in each consolidated table in the form indicated below.

Note.— The values for transition altitudes, indicated in metres and feet, are merely given for the purpose of identifying typical transition altitudes. Although pairs of values

are given in each column, this does not necessarily mean that they are equivalent.

1.1.2 Example explaining the use of the table

1.1.2.1 Assuming a given QNH value (e.g. 1 012.5 hPa) and a given transition altitude (e.g. 1 410 m) the transition level (under the conditions indicated) is FL 50. Should a transition layer of at least 300 m (1 000 ft) be required, the flight level corresponding to the transition level is 60.

1.1.3 Since the transition altitude for each location has a fixed value, the only line of the table to be used at all times is that which includes this altitude. For example, in the case of an aerodrome with a transition altitude of 1 560 m (5 200 ft), it could be:

T.A.		QNH					
		From 949.1 to 966.5	From 966.6 to 984.2	From 984.3 to 1 002.2	From 1 002.3 to 1 020.5	From 1 020.6 to 1 039.1	From 1 039.2 to 1 057.9
m	ft						
1 560	5 200	70	65	60	55	50	45

Table 1.— Transition level which will at least coincide with the flight level corresponding to the transition altitude

QNH										From	From	From	From	From	From
T.A.										942.2	959.5	977.2	995.1	1 013.3	1 031.7
m										to	to	to	to	to	to
ft										959.4	977.1	995.0	1 013.2	1 031.6	1 050.3
QNH										From	From	From	From	From	From
T.A.										945.6	963.1	980.8	998.7	1 016.9	1 035.4
m										to	to	to	to	to	to
ft										963.0	980.7	998.6	1 016.8	1 035.3	1 054.1
QNH										From	From	From	From	From	From
T.A.										949.1	966.6	984.3	1 002.3	1 020.6	1 039.2
m										to	to	to	to	to	to
ft										966.5	984.2	1 002.2	1 020.5	1 039.1	1 057.9
QNH										From	From	From	From	From	From
T.A.										952.6	970.1	987.9	1 006.0	1 024.3	1 042.9
m										to	to	to	to	to	to
ft										970.0	987.8	1 005.9	1 024.2	1 042.8	1 061.7
QNH										From	From	From	From	From	From
T.A.										956.1	973.6	991.5	1 009.6	1 028.0	1 046.7
m										to	to	to	to	to	to
ft										973.5	991.4	1 009.5	1 027.9	1 046.6	1 065.5
450	1 500	480	1 600	510	1 700	540	1 800	570	1 900	35	30	25	20	15	10
600	2 000	630	2 100	660	2 200	690	2 300	720	2 400	40	35	30	25	20	15
750	2 500	780	2 600	810	2 700	840	2 800	870	2 900	45	40	35	30	25	20
900	3 000	930	3 100	960	3 200	990	3 300	1 020	3 400	50	45	40	35	30	25
1 050	3 500	1 080	3 600	1 110	3 700	1 140	3 800	1 170	3 900	55	50	45	40	35	30
1 200	4 000	1 230	4 100	1 260	4 200	1 290	4 300	1 320	4 400	60	55	50	45	40	35
1 350	4 500	1 380	4 600	1 410	4 700	1 440	4 800	1 470	4 900	65	60	55	50	45	40
1 500	5 000	1 530	5 100	1 560	5 200	1 590	5 300	1 620	5 400	70	65	60	55	50	45
1 650	5 500	1 680	5 600	1 710	5 700	1 740	5 800	1 770	5 900	75	70	65	60	55	50
1 800	6 000	1 830	6 100	1 860	6 200	1 890	6 300	1 920	6 400	80	75	70	65	60	55
1 950	6 500	1 980	6 600	2 010	6 700	2 040	6 800	2 070	6 900	85	80	75	70	65	60
2 100	7 000	2 130	7 100	2 160	7 200	2 190	7 300	2 220	7 400	90	85	80	75	70	65

Appendix B

Flight Level Graph

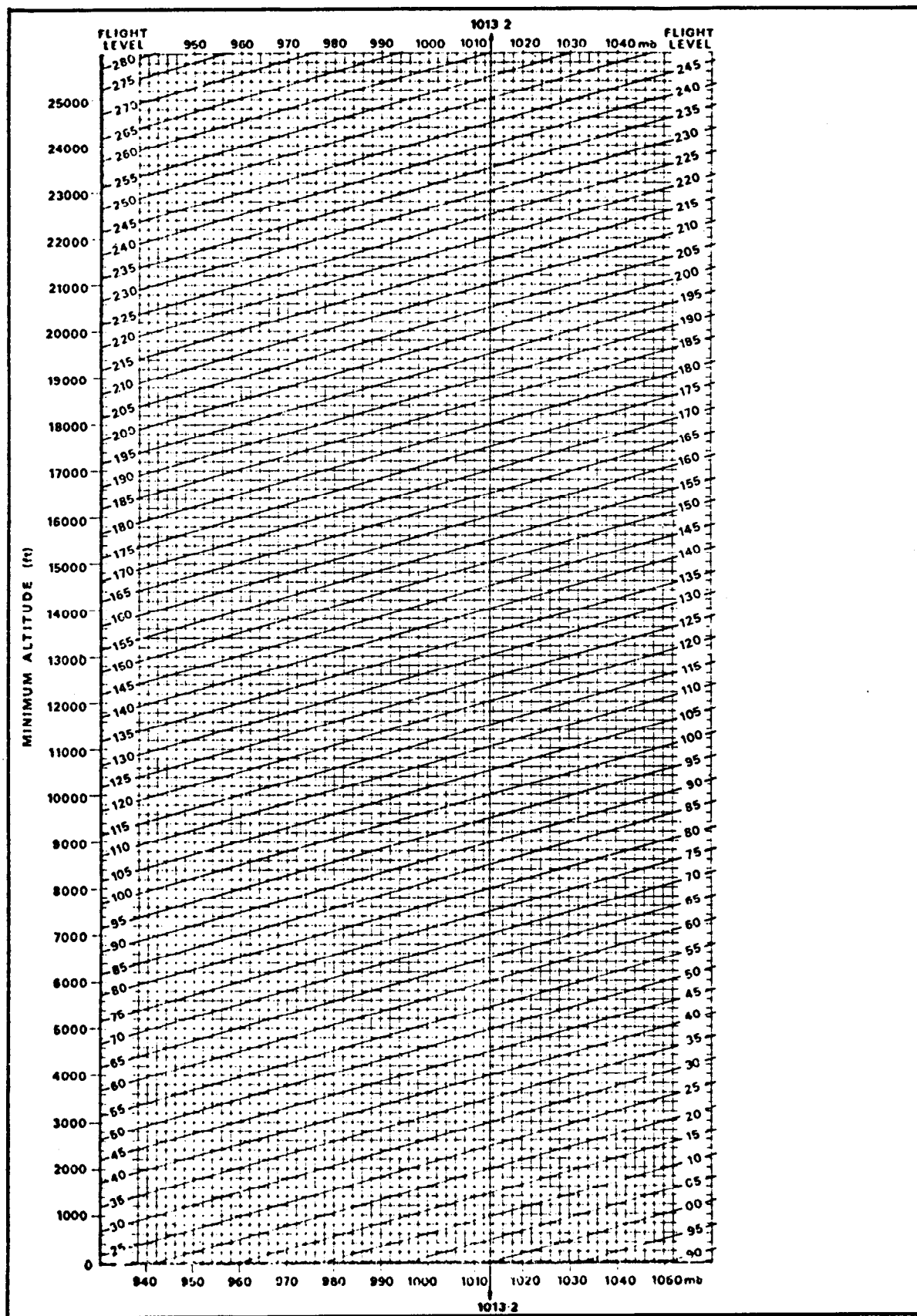

Chapter 2

Category II and III Operations

2.1 INTRODUCTION

2.1.1 Aircraft operations with limited visual reference need facilities, services and procedures at aerodromes which are additional to those required for operation in good weather. Operations in adverse weather conditions call for special procedures. Annex 6, Part I provides guidance to States in this regard; additionally, ICAO Doc 9365 — *Manual of All-Weather Operations*, contains material on the significant operational and technical aspects associated with the achievement of all-weather landing operations; Chapter 5 deals with additional requirements for category II and III operations. The manual should be used as a guide by States in their detailed planning of all-weather landing operations.

2.1.2 Those aspects of all weather operation which are of particular interest in the planning of air traffic services (ATS) in connexion with category II and III operations are highlighted in this chapter.

2.2 SYSTEM CONCEPT

2.2.1 All-weather category II and III operations are based on a total system concept. The system encompasses the need for additional and more reliable ground equipment and airborne systems capable of guiding the aeroplane with greater accuracy to the decision height and, when appropriate, through to a landing and subsequent roll out. The pilot is part of the system and takes an active role in the operation. To this effect the pilot has to be furnished with the necessary information to supervise all phases of the approach and landing and, if necessary, to assume manual control of the aircraft in order to complete the landing or carry out a missed approach procedure, if appropriate. The provision of the ATS is an essential part of the system concept in category II and III operations.

2.2.2 System reliability and integrity is achieved through design features such as low failure rates, redundancy and

a monitoring capability which allows for operational alternatives. Monitoring of all elements of the system, including both ground and airborne equipment, is essential. The pilot must be informed of any ground equipment failures affecting the status of the system, a task that is normally the responsibility of the air traffic controller.

2.2.3 Redundancy is also an important part in providing operational reliability and it is for this reason that standby facilities are used for both ground and airborne equipment. The redundant equipment may also operate in a monitoring mode by comparing its performance with that of the primary operating equipment and may provide an alert if differences exceed established values.

2.3 OPERATIONAL OBJECTIVES

2.3.1 Guidance material concerning instrument landing system (ILS) installations, operational design and maintenance objectives as well as definitions of course structure for facility performance categories is described in Annex 10, Volume I, Attachment C to Part I. Additional requirements for category II and III operations are described in Doc 9365, Chapter 5. The facility performance categories defined in Annex 10, Part I, Chapter 3 have operational objectives which are described below:

- a) Category I: Operation down to 60 m (200 ft) decision height and with a runway visual range (RVR) not less than a value of the order of 800 m (2 600 ft) with a high probability of approach success. This can be regarded as a precision approach operation achieved without the need for facilities additional to those which have been in use for several years for the classic ILS approach.
- b) Category II: Operation down to 30 m (100 ft) decision height and with an RVR not less than a value of the order of 400 m (1 200 ft) with a high probability of approach success. In this category the time available in the visual phase limits the corrections which can be made to the aircraft's flight path. Consequently, improved quality of non-visual guidance and aircraft

equipment from that required for category I is necessary. Improved approach and runway lighting systems are necessary to provide adequate visual cues. Carefully considered flight deck procedures and flight crew training are called for.

- c) Category IIIA: Operation, with no decision height limitation, to and along the surface of the runway with external visual reference during the final phase of the landing and with an RVR not less than a value of the order of 200 m (700 ft). In practice, category IIIA operations may include a decision height below 30 m (100 ft) to permit pilot confirmation that a safe automatic landing can be effected. In this operation the guidance and control systems must have the capability to permit the aircraft to land safely on the runway without visual reference but thereafter, during the landing roll, the pilot will normally control the aircraft by external visual references.
- d) Category IIIB: Operation, with no decision height limitation, to and along the surface of the runway without reliance on external visual reference, and subsequently, taxiing with external visual reference in a visibility corresponding to an RVR not less than a value of the order of 50 m (150 ft). This operation introduces a requirement to provide non-visual guidance for roll-out. Depending on the taxiway configuration, extensive improvements to taxiway lighting, marking and traffic control may be required if the attainment of the lowest limits of category IIIB is intended.
- e) Category IIIC: Operation, with no decision height limitation, to and along the surface of the runway and taxiways without reliance on external visual reference. This ultimate objective creates the need for non-visual guidance to guide the aircraft on the taxiways and on the apron. The system will also have to be applicable to emergency services and other essential vehicles, unless alternative means can be applied to provide them with facilities for rapid and safe movement while performing their tasks.

Note.— The values given above in feet are approximate rather than exact equivalents for those given in metres and they have been chosen on the basis of their operational significance in establishing RVR values.

2.3.2 It is important to note the difference between operational performance categories and facility performance categories, the latter being determined by quite different and separate technical specifications. For example, an ILS may be required to meet a specific category of facility performance which can be different from the operations performance category promulgated for the runway served by that ILS.

2.4 GROUND ENVIRONMENT

2.4.1 Electronic guidance system

2.4.1.1 ILS ground equipment consists of a localizer, glide path and two marker beacons, or a suitably sited distance measuring equipment (DME) where the siting of marker beacons is impractical. The ILS ground equipment must meet the facility performance requirements specified in Annex 10, Volume I, Part I. The quality of the ILS signal in space is not determined solely by the quality of ground equipment as the suitability of the site, including the influence of reflection from objects illuminated by the ILS signal and the manner in which the ground equipment is adjusted and maintained has a significant effect on the quality of the signal received at the aeroplane.

2.4.1.2 To ensure that the integrity of the guidance signal radiated by the ILS is maintained during aircraft approaches, all vehicles, including aircraft on the ground, must remain outside the ILS critical areas, as described in Annex 10, Volume I, Attachment C to Part I. It may also be necessary to supervise carefully the parking and movement of some types of aircraft and large vehicles in a much larger "sensitive area". If a vehicle is within the critical area, it may cause reflection or diffraction of the ILS signals which will result in significant disturbances to the guidance signals on the approach path. This problem is aggravated by the ground movement of large aircraft if they are parked or taxied in the vicinity of the ILS antennas as certain combinations of distance and size can cause serious disturbances to both the glide path and the localizer signals. Additional longitudinal separation between successive landing aeroplanes may be required to ensure the integrity of ILS guidance signals.

2.4.1.3 It is therefore essential to determine the level of interference caused by aircraft and vehicles at various positions in the sensitive area. Where this interference takes the ILS signal outside the performance limits, the area should, therefore, become part of the designated "critical area". The size of the final critical area will depend on the type of ILS, the radiated signal pattern, its achieved performance in the absence of interference and the size of the aircraft and vehicles involved in aerodrome operation. Thus for a particular ILS installation, the ATS unit and the operators concerned should develop precise criteria covering all such cases on an individual basis.

2.4.1.4 Adequate monitoring of all facilities associated with precision approaches is essential to achieve the high degree of integrity required by lower operating minima. All

facilities associated with the ILS ground equipment must be monitored in accordance with the provisions of Annex 10, Volume I, Part I. It is necessary that the pilot be made aware immediately of any operationally significant failure or degradation of service observed at a ground monitoring station. The system must ensure minimum delay in relaying essential information to the pilot and it is, therefore, extremely important that system status information, as derived from the monitor, be available to the ATS unit providing approach control service with a minimum of delay.

2.4.2 Visual aids

2.4.2.1 Approach, threshold, touchdown zone, runway edge, centre line and other aerodrome lights are required in compliance with Annex 14, appropriate to the category of operation for which a runway is intended. For daylight operations experience has shown that surface markings are an effective means of indicating the centre lines of taxiways and holding positions. A holding position sign is required at all category II and III holding positions and other signs may be needed to identify taxiways. Taxiway centre line lights or taxiway edge lights and centre line markings providing adequate guidance are required for category II and III operations.

2.4.2.2 Stop bars are also useful in limited visibility when traffic signals and signs on the sides of the taxiways may not be visible. Stop bars are required in category III visibility conditions. They are particularly effective as an added measure for preventing unauthorized entry by ground traffic to an active runway, obstacle free zone or an ILS critical or sensitive area and are a requirement for category III operation. It may be advantageous to automate, at least partially, the operation of certain stop bars so that the air traffic controller will not be required to operate them manually, thus avoiding the possibility of human error. For example, a manual switch off of a stop bar after issue of a movement clearance would be followed by an automatic re-illumination by the crossing aeroplane or, a "limited visibility" setting on the control panel would automatically illuminate stop bars across taxiways which are not to be used in limited visibilities. Controlled stop bars, when combined with taxiway centre-line lights, lighted only for the route to be followed, provide efficient control for ground movement.

2.4.2.3 Ideally, all lighting should be monitored by the air traffic controller and information on system failure or downgrading made available to the pilot in compliance with Annex 15.

2.5 AIR TRAFFIC SERVICES

2.5.1 The provision of aerodrome control service is considered essential at aerodromes planned for categories II and III operations. The information to be provided to pilots is specified in Annex 11 and in the *Procedures for Air Navigation Services — Rules of the Air and Air Traffic Services* (PANS-RAC, Doc 4444), Part IV. Guidance on the responsibilities of ATS regarding surface movement guidance and control is given in ICAO Circular 148 — *Surface Movement Guidance and Control Systems*. The ATS unit must ensure that pilots are kept informed of any change in the status of airport facilities at their destinations and at their alternate aerodromes. In some locations, the ATS unit concerned may require a discrete frequency for communicating information to aircraft at the commencement of an approach and during the final approach, landing and roll-out phases. Where provided, an automatic terminal information service (ATIS) will assist operations prior to the commencement of final approach, but may not normally be updated frequently enough to eliminate the need to pass additional information to pilots engaged in operations lower than category I.

2.5.2 Because ILS signals can be disturbed by reflections caused by aeroplanes overflying the localizer, ATS units must ensure that, when category II or III operations are being conducted, aeroplanes do not take off from the landing runway after an aeroplane on final approach has reached a certain point. For instance, clearance for take-off should be given so as to ensure that the departing aeroplane has overflown the ILS localizer antenna before the arriving aeroplane has descended to 60 m (200 ft). This is necessary to preserve the integrity of the precision guidance system during the time when the landing aircraft is critically dependent on the quality of the signal in space. For the same reason, additional longitudinal separation may be required between successive aircraft conducting category II and III operations.

2.5.3 When designing approach procedures for use in conjunction with category II and III ILS facilities, it is desirable to make provisions whereby aircraft equipped for low visibility operations will not be delayed unnecessarily by aircraft not so equipped. Such consideration may require special holding procedures, or special radar vectoring procedures. However, when category II or III operations do not prevail, all aircraft should be afforded normal priorities by ATS units (see also Part I, Section 2, Chapter 7, 7.3.9).

2.5.4 ATS units should recognize the need for aircraft to simulate low minima approaches in good weather

conditions so that both crew and equipment can gain practical exposure. Approval to conduct such an exercise should be requested by the pilot and ATS units should agree to such a request whenever traffic will permit. While this exercise is being conducted, ATS units should, where feasible, restrict take-offs and ground manoeuvring to the same extent as if actual low minima conditions existed. When this is not feasible, ATS should advise the pilot accordingly (see also Part I, Section 2, Chapter 7, 7.3.10).

2.6 AERONAUTICAL INFORMATION SERVICE (AIS)

The efficient operation of the AIS is essential to category II and III operations so that pilots, at the flight planning stage, are kept informed of the status of all aerodrome facilities appropriate to the flight. Changes in, or degradation of, any operationally significant aerodrome facility must be immediately notified to the appropriate AIS units. Annex 15, Chapter 7 outlines some of the requirements which must be met in this respect.

2.7 METEOROLOGY

2.7.1 Annex 3 — *Meteorological Service for International Air Navigation* and the *Manual of Aeronautical Meteorological Practice* (Doc 8896) specify the various types of meteorological information and service which is necessary to meet the requirements for take-offs and landings in low visibility conditions. They contain provisions regarding the location of ground measuring instruments and their tolerances.

2.7.2 There is also a requirement for an RVR system to be used for the measurement of this element with a high degree of accuracy, reliability and integrity. Any significant change in RVR values should be available to ATS, for transmission to the pilot, within 15 seconds and with less delay if possible. Detailed material on RVR observing and reporting practices is contained in ICAO Doc 9328 — *Manual of Runway Visual Range Observing and Reporting Practices*.

2.8 GROUND MOVEMENT CONTROL

2.8.1 ICAO Circular 148 — *Surface Movement Guidance and Control Systems* provides information on appropriate

combinations of visual aids, non-visual aids, applicable radiotelephony (RTF) procedures and control and information facilities. The system to be adopted at a particular aerodrome should be designed to meet the operational requirements for that particular aerodrome.

2.8.2 Ground movement control procedures should ensure that the runway is kept free of obstructions during any period when the runway is required for take-off and landing operations. The main purpose of ground movement control in low visibility operations is:

- a) to avoid traffic conflicts between taxiing aircraft or between an aircraft and a ground vehicle;
- b) to ensure that aircraft or ground vehicles do not enter the ILS critical or sensitive areas at an improper time;
- c) to ensure clearance of the runway in use when an aircraft is landing or taking off;
- d) to facilitate the taxiing to and from the runway;
- e) to maintain the maximum safe capacity of the airport.

2.8.3 Normal procedures and aids which facilitate movement on a busy aerodrome are generally adequate in visibility conditions down to about 150 m (500 ft). Plans for ground movement of aircraft and vehicles during periods of low visibility (category II or IIIA conditions) should be based on maximum use of procedures and aids which are common for operations in good visibility. In low visibility conditions, all aircraft and other vehicles operated on the manoeuvring area of the aerodrome must be subject to the control of the aerodrome controller.

2.8.4 Additionally, and in order to ensure that aircraft and vehicles can operate on the ground with efficiency and safety in low visibility, an effective means must also be provided to substitute for the lack of visual reference normally used by pilots and controllers. The primary means of control and surveillance of ground traffic in low visibility conditions can be procedural, using radio voice communications between the aerodrome controller and the pilot (or vehicle operator), supplemented by visual information for the pilot in the form of lights, surface markings, and signs. Control may also include accompaniment by an escort who is in direct radiocommunication with the aerodrome controller.

2.8.5 Control and/or surveillance will be improved by the use of such supplementary facilities and equipment as aerodrome surface movement radar, controllable taxiway lights, stop bars, signs, and local detectors, i.e. induction loops, intrusion alarm devices, etc.

2.8.6 Although existing visual aids and procedures can be employed for ground movement in low visibility, such

operations must be conducted with extra caution and procedures must be applied which may limit traffic. To simplify these procedures and minimize the potential for conflict, it is advantageous to minimize the number of options for taxi routes between parking areas and runways.

2.8.7 To ensure that aircraft with authority to take off in low visibility are not blocked on taxiways by others who must wait for improved visibility, it is advantageous to grant taxi clearance only to those aircraft able to take off in low visibility. In such cases a holding area, away from the terminal, would be required to permit safe passage of those taxiing aircraft which will be authorized for take-off.

2.8.8 When stop bars are not used on taxiways and there may be a potential traffic conflict along taxi routes, it is preferable to grant clearance to taxi only to an intermediate holding point where the potential conflict may be assessed and avoided by subsequent direction. Upon reporting its arrival at the holding point, the aircraft may be subsequently cleared to continue taxiing if the controller is assured that no conflicting traffic exists.

2.8.9 Clearance to taxi, acknowledgement of the clearance, and position reports on the taxi route should be clear and concise, as in flight, in order to avoid misunderstanding between the aerodrome controller and the pilot. This is particularly important with respect to control of ground movements near an active runway. Controlling authorities must bear in mind that they have the responsibility to ensure that active runways and ILS critical areas are clear and that pilots are totally dependent on the controllers for such assurance during operations in low visibility.

2.8.10 In category II and III conditions, it is highly desirable that ground movement control be effected by the use of a discrete communication frequency, separate from the local control frequency used for aircraft in flight. Radiocommunication on the frequency used by pilots making a final approach in low visibility should be limited

to that which is essential to the pilot making the approach. Experience has indicated that when aircraft land sequentially at minimum time intervals in low visibility, it is desirable for pilots to report on the local control frequency when they are clear of the runway. Subsequent communications should be on the ground control frequency.

2.8.11 When no special surveillance equipment is employed and control of traffic on the manoeuvring area of the aerodrome is maintained by procedures and visual aids, unauthorized traffic must be restricted from gaining access to the manoeuvring area by local security measures. Normally, it may be expected that routine measures for preventing unauthorized traffic on the air side of an aerodrome will be adequate for low visibility operations (i.e. security fences around the aerodrome, signs restricting unauthorized access, and limiting access only to those vehicle operators who are familiar with essential precautions and procedures). When the local situation is such that routine measures may not be adequate, special measures should be taken to provide surveillance and control, particularly for the ILS critical areas and active runways. For example, when construction or maintenance vehicles are engaged in mobile activities on the aerodrome at the onset of category II or III operations, it may be necessary to terminate their activity and remove them from the aerodrome until the visibility improves. Alternatively, it may be appropriate to accompany such vehicles with a radio controlled escort while the low visibility condition prevails.

2.8.12 Aerodrome surveillance radars have been found useful as an aid for ground controllers to monitor and assist traffic on an aerodrome. However, a basic radar display may be difficult to interpret because of the effects of precipitation, high ambient light in the control tower, and lack of adequate resolution. Other systems using such devices as improved radar displays, Doppler radar, induction loop detectors, and intrusion alarm devices are being used or tested at some major aerodromes to meet a local situation (see also Part II, Section 5, Chapter 4).

Chapter 3

Wake Turbulence

3.1 INTRODUCTION

3.1.1 The purpose of the material contained herein is to provide air traffic controllers with a thorough understanding of situations where hazardous wake turbulence may exist and to recommend appropriate separation minima for use when wake turbulence is likely to exist. The material is intended to serve as a link between the wake turbulence categorization of aircraft and increased longitudinal separation minima recommended herein and regulatory material which is envisaged for applicability in 1990.

3.1.2 In the past there was insufficient agreement on the correlation between wake turbulence research and operational experience to state with an acceptable degree of certainty what weight classifications should be applied to aircraft and what separation should be applied between different kinds of aircraft. Techniques for detecting wake vortices near ground level were available and residence times of vortices detected near ground levels have been recorded in several parts of the world. Operational experience with actual in-flight wake turbulence encounters was well documented. The recent analysis of wake turbulence data collected by certain States has yielded yet more definitive criteria and the conflict between safety and expedition, between caution and regularity and between separation minima and runway acceptance rate has now been resolved. Much the way aircraft noise is the by-product of thrust, aircraft wake turbulence is the by-product of lift. If the harmful effects of noise on communities near aerodromes can produce regulations for its alleviation, so can the potential hazard of wake turbulence.

3.1.3 Wake vortices are present behind every aircraft, but are particularly severe when generated by a large and wide-bodied jet aircraft. These vortices are two counter-rotating cylindrical air masses trailing aft from the aircraft (see Figure 1). The vortices are most dangerous to following aircraft during the take-off, initial climb, final approach and landing phases of flight. They tend to drift down and

when close to the ground move sideways from the track of the generating aircraft, occasionally rebounding upwards.

3.1.4 The term "wake turbulence" is used in this chapter to describe the effect of the rotating air masses generated behind the wing tips of large jet aircraft in preference to the term "wake vortex" or "wake vortices" which describes the nature of the air masses.

3.1.4.1 According to recent studies, there is turbulence in the wake being generated by the aircraft as well as in the atmosphere. The latter can become just as potentially hazardous in the form of low-level wind shear and clear air turbulence as wake vortices. It is extremely important to make a distinction between these two highly organized, counter-rotating cylindrical air masses trailing aft from aircraft, and the naturally occurring atmospheric turbulence.

3.2 SEPARATION MINIMA

3.2.1 Application of minima

3.2.1.1 Wake turbulence separation minima are intended to greatly reduce the potential hazards of wake turbulence. However, when the separation minima normally applied to instrument flight rules (IFR) flights are greater than those for wake turbulence, no special measures need to be taken by air traffic control (ATC) since the IFR minima apply.

3.2.1.2 Because wake turbulence is invisible, its presence and location cannot be determined with precision. Controllers, therefore, as well as pilots, should thoroughly understand the likely situations where hazardous wake turbulence may be encountered. Wake turbulence separation minima specified in this chapter should be applied for any situation not covered by other specified minima whenever a controller believes there is a potential hazard due to wake turbulence.

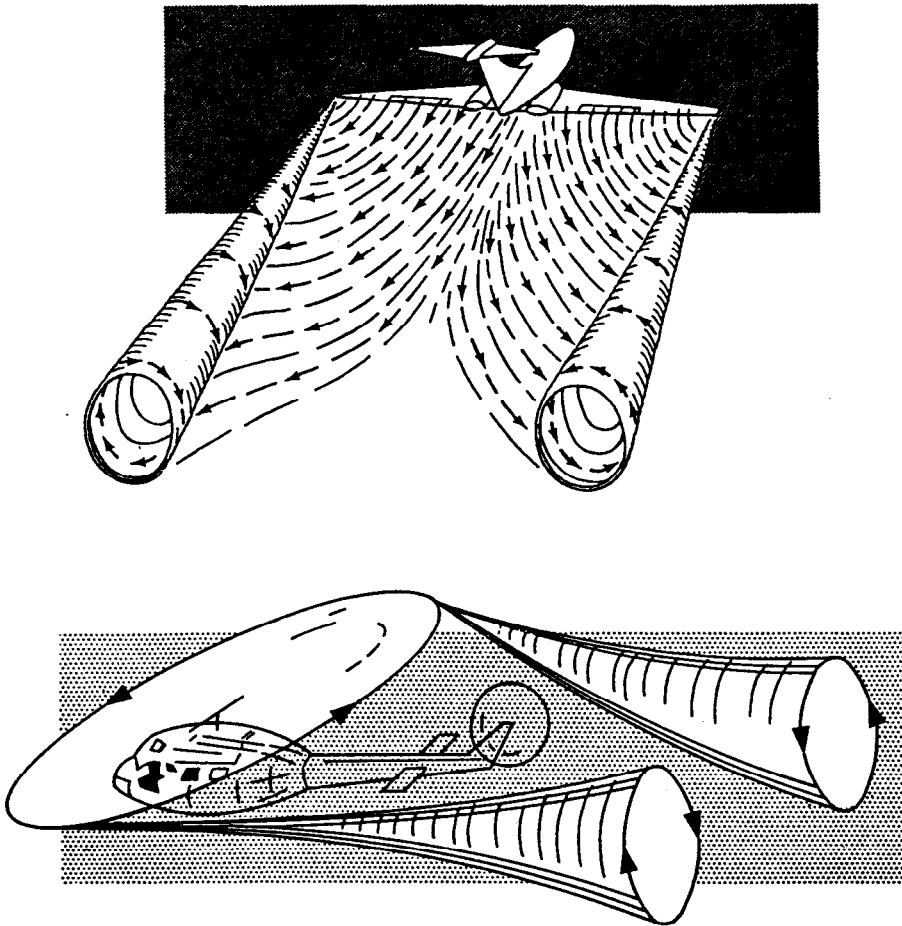

Figure 1.— The rolling-up process

3.2.2 Effects on aircraft

The three basic effects of wake turbulence on a following aircraft are induced roll, loss of height or rate of climb, and possible structural stress. The greatest danger is the roll induced on the penetrating aircraft to the degree that it exceeds the counter control capability of the aircraft concerned. Should the wake turbulence encounter occur in the approach area, its effect is greater because the following aircraft is in a critical state with regard to speed, thrust, altitude and reaction time.

3.2.3 Categorization of aircraft

3.2.3.1 Wake turbulence separation minima should be based on a grouping of aircraft types into three categories according to the maximum certificated take-off mass.

3.2.3.2 The recommended categories are:

- a) HEAVY (H) — all aircraft types of 136 000 kg or more;
- b) MEDIUM (M) — aircraft types less than 136 000 kg and more than 7 000 kg;
- c) LIGHT (L) — aircraft types of 7 000 kg or less.

Note.— Wake turbulence aircraft categories and separation minima contained in this chapter will become applicable for inclusion in the PANS-RAC (Doc 4444), as regulatory material, on 15 November 1990.

3.2.4 Minima related to conditions

3.2.4.1 Based on the knowledge and experience accumulated to date, the following separation minima are offered as guidance.

3.2.4.2 Radar separation minima

Aircraft categories		Separation minima
Leading aircraft	Following aircraft	
HEAVY	HEAVY	7.4 km (4.0 NM)
	MEDIUM	9.3 km (5.0 NM)
	LIGHT	11.1 km (6.0 NM)
MEDIUM	HEAVY	5.6 km (3.0 NM)
	MEDIUM	5.6 km (3.0 NM)
	LIGHT	9.3 km (5.0 NM)
LIGHT	HEAVY	5.6 km (3.0 NM)
	MEDIUM	5.6 km (3.0 NM)
	LIGHT	5.6 km (3.0 NM)

Note.— See Figure 2.

3.2.4.2.1 The separation minima set out in 3.2.4.2 above should be applied when:

- a) an aircraft is operating directly behind another aircraft at the same altitude or less than 300 m (1 000 ft) below; or
- b) both aircraft are using the same runway, or parallel runways separated by less than 760 m; or
- c) an aircraft is crossing behind another aircraft, at the same altitude or less than 300 m (1 000 ft) below.

3.2.4.3 Non-radar separation minima

3.2.4.3.1 Arriving aircraft

For timed approaches, the following separation minima should be applied to aircraft landing behind a HEAVY or a MEDIUM aircraft as follows:

- a) MEDIUM aircraft behind HEAVY aircraft — 2 minutes;
- b) LIGHT aircraft behind a HEAVY or MEDIUM aircraft — 3 minutes.

3.2.4.3.2 Departing aircraft

3.2.4.3.2.1 Except as set in 3.2.4.3.2.2, a minimum of 2 minutes should be applied between a LIGHT or MEDIUM aircraft taking off behind a HEAVY aircraft or a LIGHT aircraft taking off behind a MEDIUM aircraft when the aircraft are using:

- a) the same runway;
- b) parallel runways separated by less than 760 m;
- c) crossing runways if the projected flight path of the second aircraft will cross the projected flight path of the first aircraft at the same altitude or less than 300 m (1 000 ft) below;
- d) parallel runways separated by 760 m or more, if the projected flight path of the second aircraft will cross the

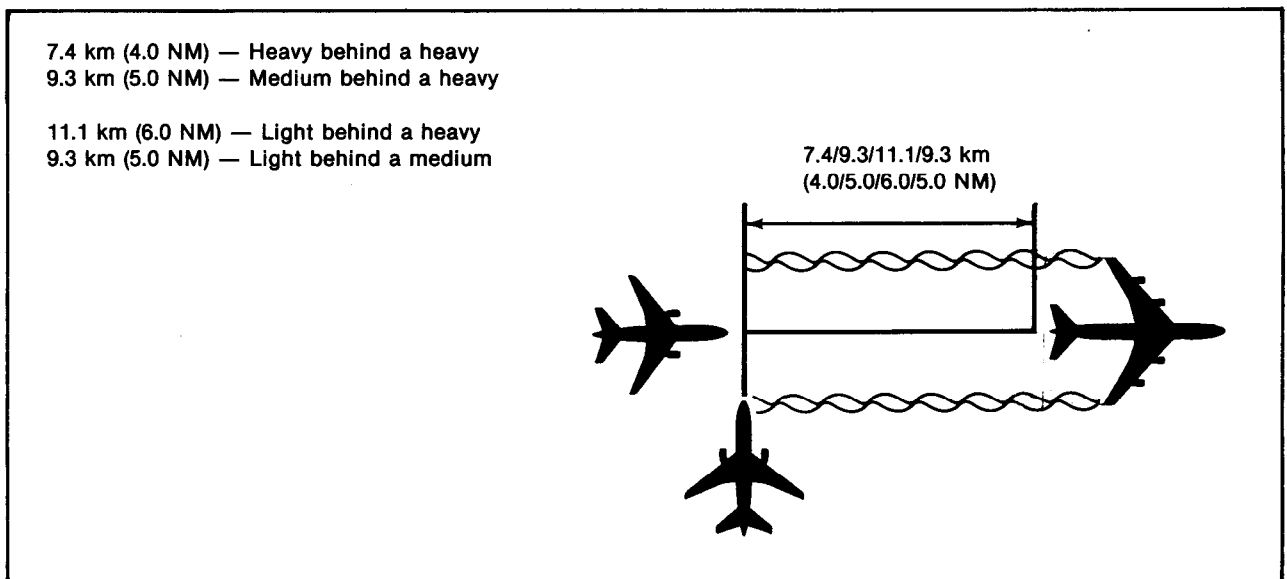

Figure 2.— Wake turbulence separation minima for crossing and following aircraft (see 3.2.4.2)

projected flight path of the first aircraft at the same altitude or less than 300 m (1 000 ft) below.

Note.— See Figures 3 and 4.

3.2.4.3.2.2 A separation minimum of 3 minutes should be applied between a LIGHT or MEDIUM aircraft when

taking off behind a HEAVY aircraft or a LIGHT aircraft when taking off behind a MEDIUM aircraft from:

- a) an intermediate part of the same runway; or
- b) an intermediate part of a parallel runway separated by less than 760 m.

Note.— See Figure 5.

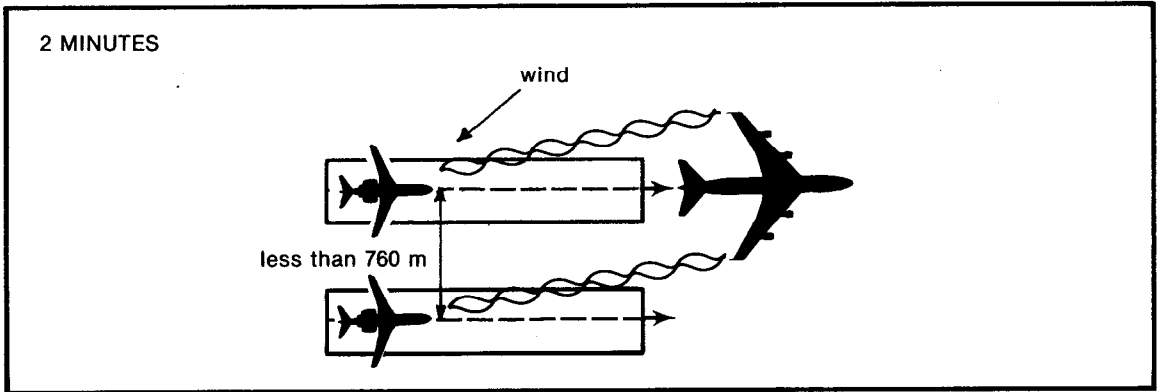

Figure 3
(see 3.2.4.3.2.1)

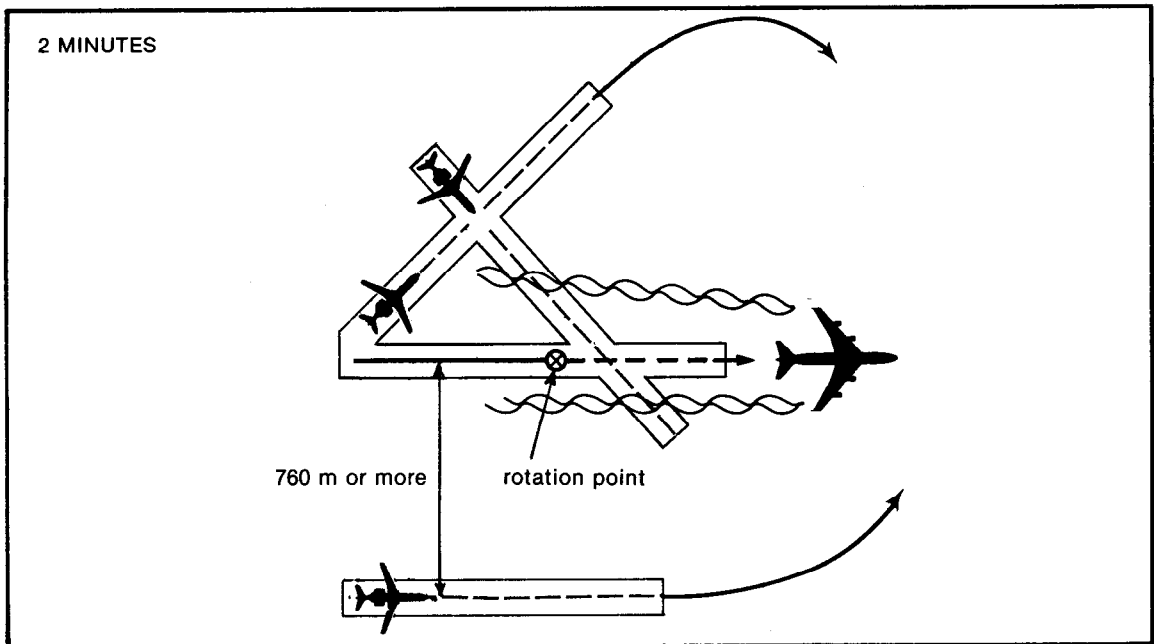

Figure 4
(see 3.2.4.3.2.1)

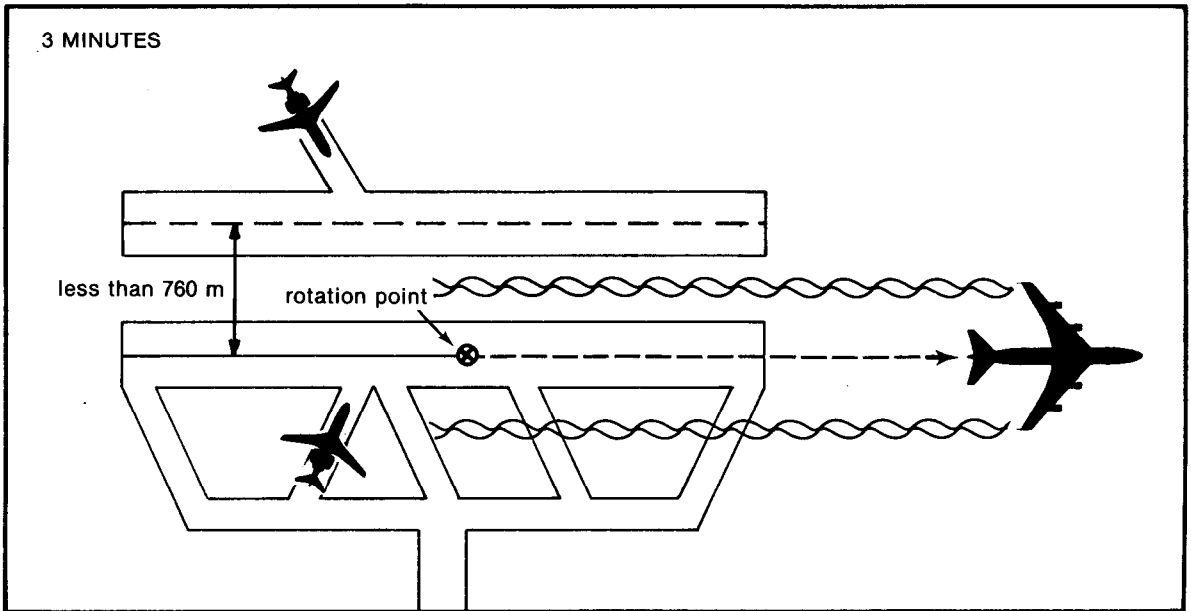

Figure 5
(see 3.2.4.3.2.2)

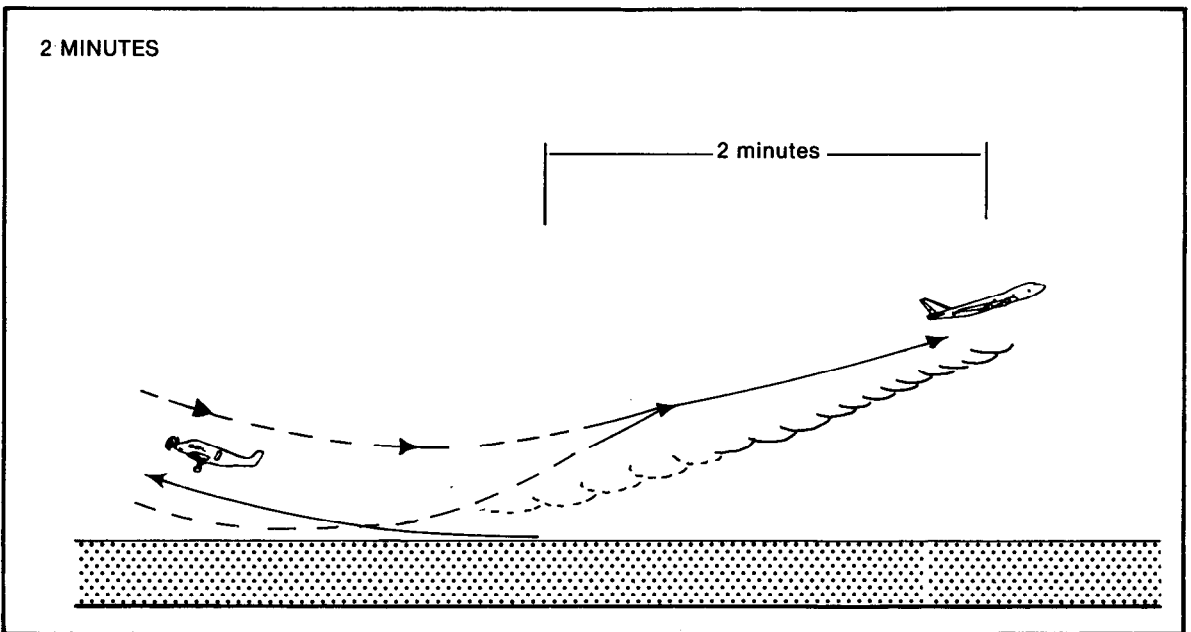

Figure 6.— For opposite-direction aircraft
(see 3.2.4.5 a))

3.2.4.4 Displaced landing threshold

A separation minimum of 2 minutes should be applied between a LIGHT or MEDIUM aircraft and a HEAVY aircraft and between a LIGHT aircraft and a MEDIUM aircraft when operating on a runway with a displaced landing threshold when:

- a) a departing LIGHT or MEDIUM aircraft follows a HEAVY aircraft arrival and a departing LIGHT aircraft follows a MEDIUM aircraft arrival; or
- b) an arriving LIGHT or MEDIUM aircraft follows a HEAVY aircraft departure and an arriving LIGHT aircraft follows a MEDIUM aircraft departure if the projected flight paths are expected to cross.

3.2.4.5 Opposite direction

A separation minimum of 2 minutes should be applied between a LIGHT or MEDIUM aircraft and a HEAVY aircraft, and between a LIGHT aircraft and a MEDIUM aircraft when the heavier aircraft is making a low or missed approach and the lighter aircraft is:

- a) utilizing an opposite-direction runway for take-off; or

Note.— See Figure 6.

- b) landing on the same runway in the opposite direction, or on a parallel opposite-direction runway separated by less than 760 m.

Note.— See Figure 7.

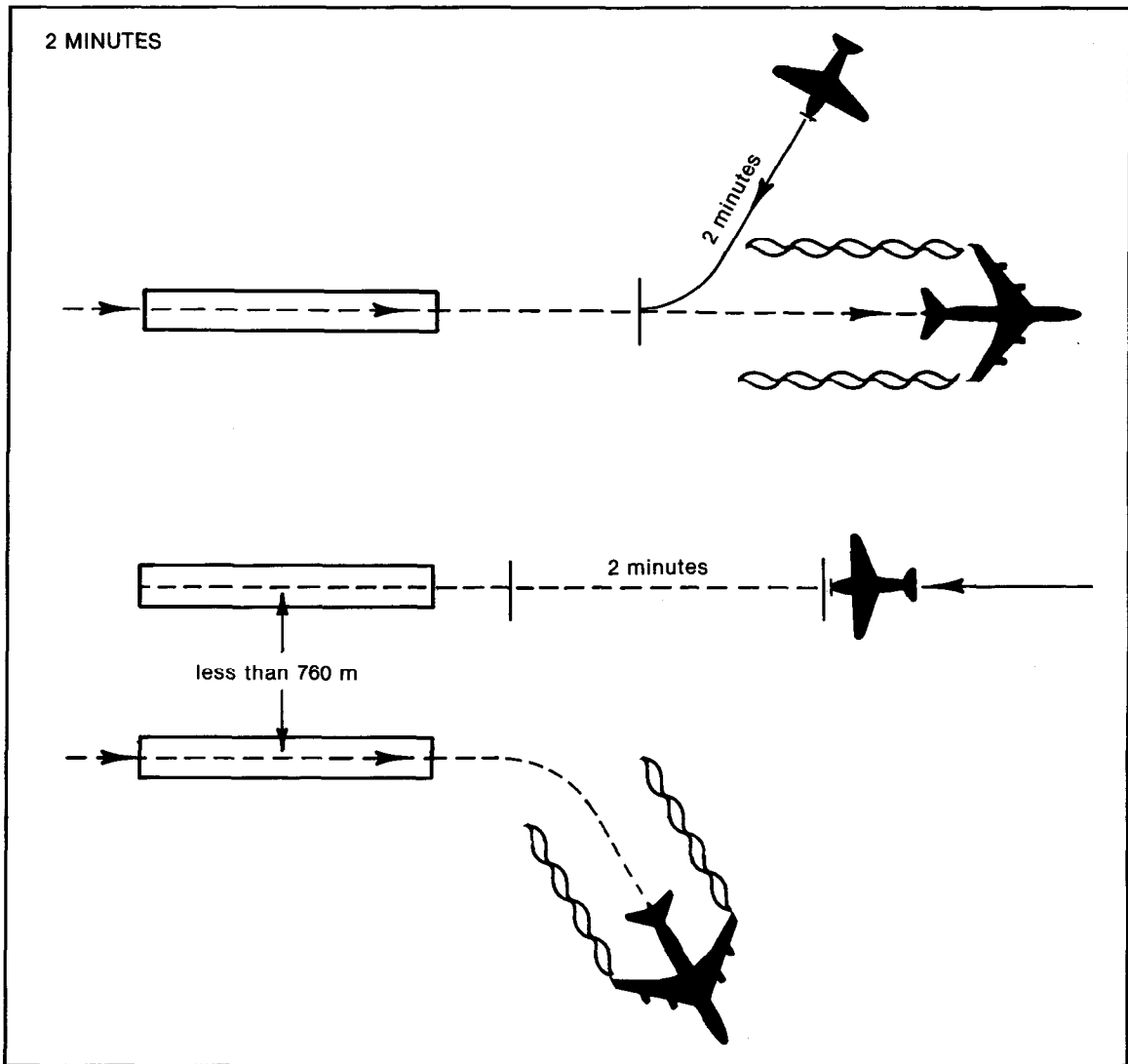

Figure 7.— For opposite-direction aircraft (see 3.2.4.5 b))

3.2.5 Cautionaries

Figure 8 gives examples of cases where aerodrome controllers should advise aircraft of the potential existence of wake turbulence.

3.2.6 Jet blast

In issuing clearances or instructions, air traffic controllers should take into account the hazards caused by jet blast and propeller slipstream to taxiing aircraft, to aircraft taking off or landing, particularly when intersecting runways are being used, and to vehicles and personnel operating on the aerodrome.

Note.— Jet blast and propeller slipstream can produce localized wind velocities of sufficient strength to cause damage to other aircraft, vehicles and personnel operating within the affected area.

3.3 MINIMIZING THE EFFECT OF WAKE TURBULENCE

3.3.1 General

The information presented below is not intended to give the impression that ATC may reduce the prescribed wake turbulence separation minima. It is only intended to preclude the need to increase the wake turbulence separation beyond the minima by avoiding, when and where practicable, occasions where conditions are most likely to result in wake turbulence encounters. It follows that the application of the wake turbulence minimum is not an assurance against a wake turbulence encounter; its application only minimizes the hazard.

3.3.2 The ATC dilemma

3.3.2.1 The primary concern of ATC in applying wake turbulence procedures is to minimize the effects of such turbulence on aircraft. ATC must also be concerned with aerodrome capacity and its own ability to discharge its responsibility for expediting air traffic as efficiently as possible.

3.3.2.2 Discharging such responsibility while at the same time having to assess the potential behaviour and location of invisible air currents creates a dilemma for the air traffic

controller. The guidance material prescribed in this chapter will help in resolving the controllers' dilemma on wake turbulence.

3.3.3 Wake turbulence characteristics

3.3.3.1 Wake vortices generated by an aircraft in flight are related to the aircraft gross mass, airspeed, configuration and wing span. Vortex characteristics are altered and eventually dominated by interactions between the vortices and the ambient atmosphere. The wind, wind shear, turbulence and atmospheric stability affect the motion and decay of a vortex system. The proximity of the ground significantly affects vortex movement and decay.

3.3.3.2 Vortex generation begins on rotation when the nose wheel lifts off the runway and ends when the nose wheel touches down on landing. Vortex strength increases proportionally to weight and is greatest when the generating aircraft is HEAVY, in a clean configuration, and is flying slowly.

3.3.3.3 Helicopters produce vortices when in flight and there is some evidence that, per kilogram of gross mass, their vortices are more intense than those of fixed-wing aircraft. When hovering or while hover-taxiing helicopters should be kept well clear of light aircraft.

3.3.3.4 Special attention needs to be given to situations of light wind where vortices may remain for a considerable time in the approach and runway touchdown areas, drift to a parallel runway, or sink to the landing or take-off paths of succeeding aircraft.

3.3.3.5 Vortices generally dissipate or break up in one of three ways:

- a) over a long period of time, turbulent diffusion can enlarge each wake so that the wakes merge and dissipate;
- b) disturbances along the length of the vortices become unstable and sinuous oscillations develop which cause the vortices to touch and link together;
- c) a sudden structural change known as vortex breakdown or bursting can abruptly widen the vortex core.

3.3.3.6 Ground effect becomes an important factor when considering the movement and decay of the vortices. The ground acts as a plane of reflection; as the trailing vortices descend toward the ground their vertical velocity decreases and, with no or little wind, they begin to travel horizontally over the ground away from each other at a height approximately half the wing span of the generating aircraft.

Caution an aircraft approaching behind a departing heavy aircraft, or a light aircraft behind a medium aircraft, using a crossing runway if flight paths will cross.

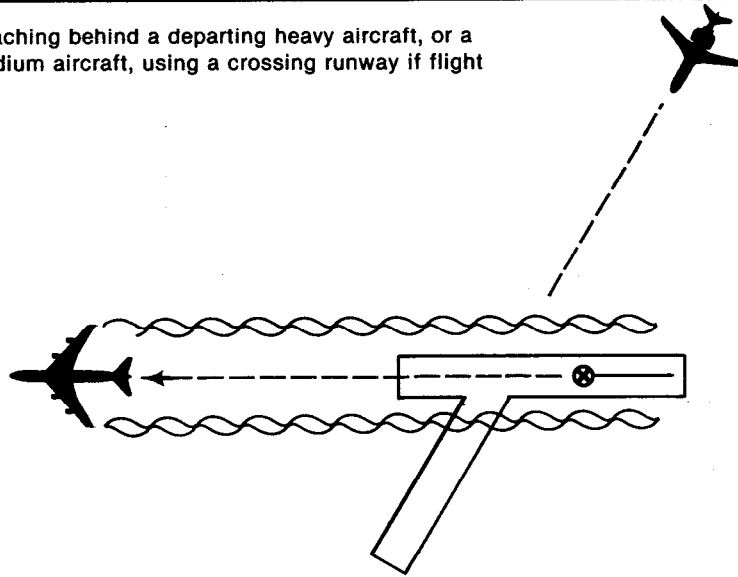

WATCH FOR

- a) calm wind conditions;
- b) a light cross wind or tail wind which could keep the wake turbulence on the runway; and
- c) wake turbulence drifting to another runway.

Do not approve rolling take-off by a heavy aircraft if its jet engine blast may be hazardous to a following aircraft or vehicle, or to ground fixtures.

Caution an aircraft approaching behind an arriving heavy aircraft, or a light aircraft behind a medium aircraft, approaching:

1. the same runway;
2. a parallel runway less than 760 m away; or
3. a crossing runway when flight paths will cross.

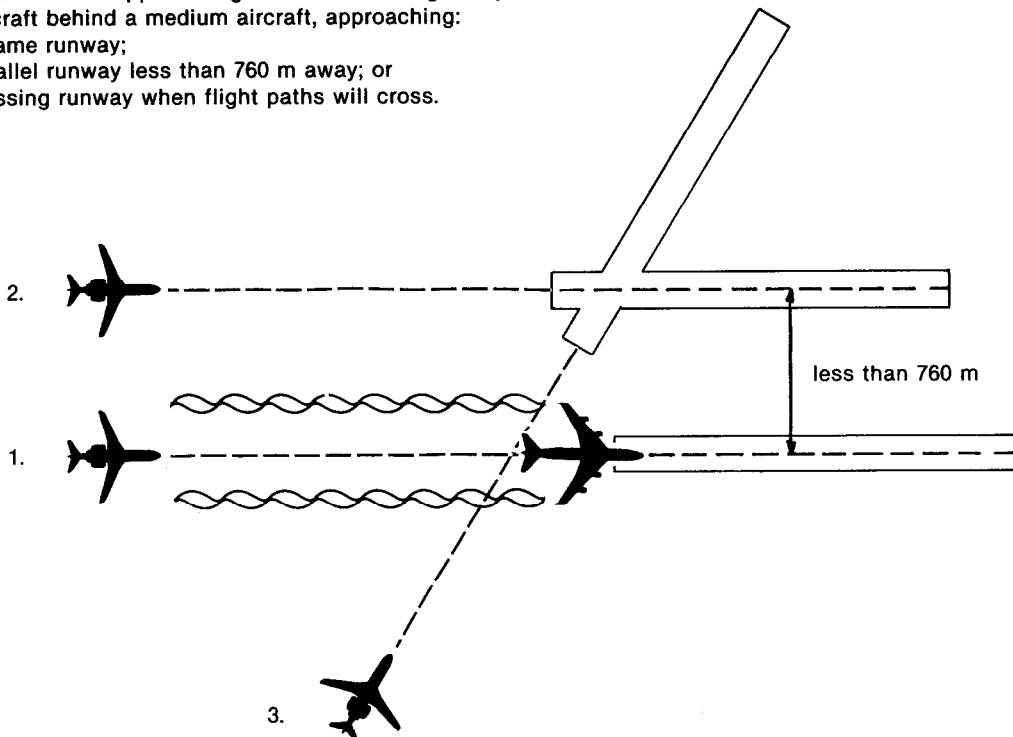

Figure 8.— Cautionaries — Visual flight rules (VFR) and visual approaches (see 3.2.5)

3.3.4 On the provision of air traffic services (ATS)

For aircraft in the “HEAVY” wake turbulence category the word “HEAVY” should be included immediately after the aircraft call sign in the initial radiotelephony contact between such aircraft and the aerodrome control tower or the approach control office prior to departure or arrival. Wake turbulence categories are specified in the instructions for completing Item 9 of the ICAO flight plan.

3.3.5 On the provision of area control service

The provision of vertical or horizontal separation is not applicable to a flight while it is cleared to maintain its own separation and remain in visual meteorological conditions (VMC). Any flight so cleared has therefore to ensure that, for the duration of the clearance, it is not operated in such proximity to other flights as to create a collision hazard and so as not to incur the hazards resulting from wake vortices.

3.3.6 On the provision of approach control service

3.3.6.1 To cater for wake turbulence, in addition to the provisions in 3.3.3 and 3.3.5 above and in relation to the establishment of controlled airspace, the lower limit of a control area should, whenever possible, be established at a greater height than the minimum specified, i.e. 200 m (700 ft) in order to allow freedom of action for VFR flights. Whenever there is a significant potential hazard from wake turbulence descending into a control zone or ATS route, the lower limit of such airspace should be at such a height that there is not less than 300 m (1 000 ft)

between the flight levels or altitudes used by flights above the lower limit and those used by flights below the lower limit of the control area when the control of such flights is the responsibility of separate ATC units (see Figure 9). Such a relationship also exists when separation is the responsibility of a single ATC unit, such as when vertical separation is being applied to IFR flights.

3.3.6.2 Flight tests have shown that vortices from large aircraft sink at a rate of about 2 to 2.5 m/s (400 to 500 ft/min). They tend to level off at about 275 m (900 ft) below the flight path of the generating aircraft. Wake turbulence strength diminishes with time and distance behind the generating aircraft. Atmospheric turbulence hastens breakup of the vortices. The vortex circulation is outward, upward and around the wing tips when viewed from either ahead of or behind the aircraft. Tests with large aircraft have shown that the vortex flow field, in a plane cutting through the wake at any point downstream, covers an area about two wing spans in width and one wing span in depth, the wing span being that of the generating aircraft (see Figure 10). It may be helpful to visualize vortex circulation in conjunction with the sink rate shown in Figure 9. The vortices remain spaced, about a wing span apart, and drift with the wind, at altitudes greater than a wing span from the ground. If persistent wake turbulence is encountered by an aircraft which is being separated by radar from a large aircraft, a slight change of altitude and lateral position (preferably upwind) will provide a flight path clear of the vortices. Aircraft should be operated at or above the flight path of the large aircraft, changing course as necessary to avoid the area behind and below the large aircraft that is generating the wake turbulence.

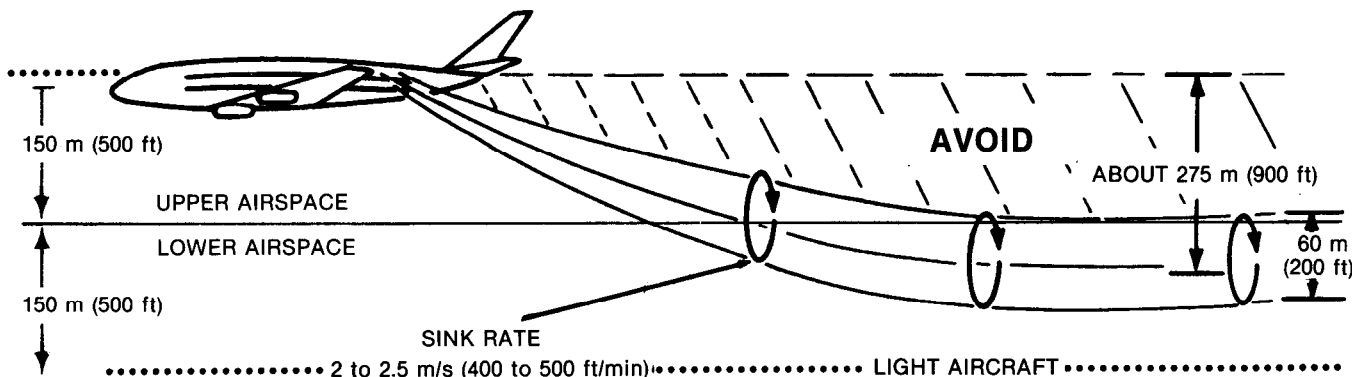

Figure 9

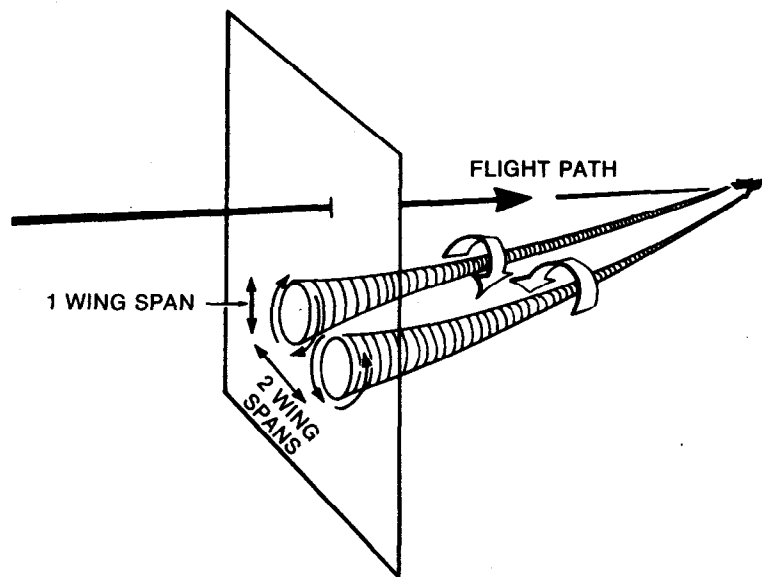

Figure 10

3.3.6.3 In rare instances, a wake turbulence encounter could cause in-flight structural damage of catastrophic proportions. However, the usual hazard is associated with induced roll, as described in 3.2.2.1, which can exceed the roll capability of the encountering aircraft. Counter control is usually effective and induced roll minimal in cases where the wing span and ailerons of the encountering aircraft extend beyond the rotational flow field of the vortex. It is more difficult for aircraft with a short wing span (relative to that of the generating aircraft) to counter the imposed roll induced by vortex flow. Pilots of short-span aircraft, even of the high performance type, should be especially alert to wake turbulence encounters and should be handled accordingly by air traffic control. Figure 11 depicts the above relationship.

3.3.6.4 For data collection purposes, wake turbulence encounters have been classified (by one State) according to the reported roll angle, as follows:

a) Severe — a reported roll angle in excess of 30° with full opposite aileron applied.

b) Moderate — a reported roll angle of 10 to 30° .
c) Slight — a reported roll angle of less than 10° .

3.3.6.5 ATS authorities should ensure that records are kept of wake turbulence encounters. These records should indicate the severity of the encounter, the flight path and altitude of the encountering aircraft, and if possible, that of the generating aircraft, and the spacing between aircraft. Wind speed and direction, as reported by the aerodrome and/or approach controller, may have a bearing on the encounter in certain circumstances. Since the reporting system should be designed for analysing the effectiveness of applied wake turbulence separation minima it should not be more complicated than is absolutely necessary.

3.3.7 On the provision of aerodrome control service

3.3.7.1 The responsibility for wake turbulence avoidance exercised by the aerodrome control service for other than IFR flights will remain as stated in 3.2.1, until such time as

there is an acceptable degree of certainty as to the "residence times" of wake vortices along the flight paths of arriving aircraft.

3.3.7.2 The use of radar in the provision of aerodrome control service may bring about the adoption of an integrated radar/visual IFR/VFR form of aerodrome and approach control service. In an ATC environment where radar is used extensively, the application of radar minima would be largely academic, since the wake turbulence separation minima would be equal to or greater than the radar minima and would, by necessity, have to be applied to all flights operating in such an environment.

3.4 VORTEX SENSING AND TRACKING DEVELOPMENTS

There are several kinds of wind-sensing systems. In general, a wake vortex sensor must interact with some physical property of the vortex. The usefulness of the sensor depends upon how closely the property sensed is related to the property which is to be determined. Vortex sensing equipment is important to air traffic controllers and pilots because it has the capability of providing information on the presence and strength of vortices. A brief description of wake vortex avoidance systems is included in Appendix A.

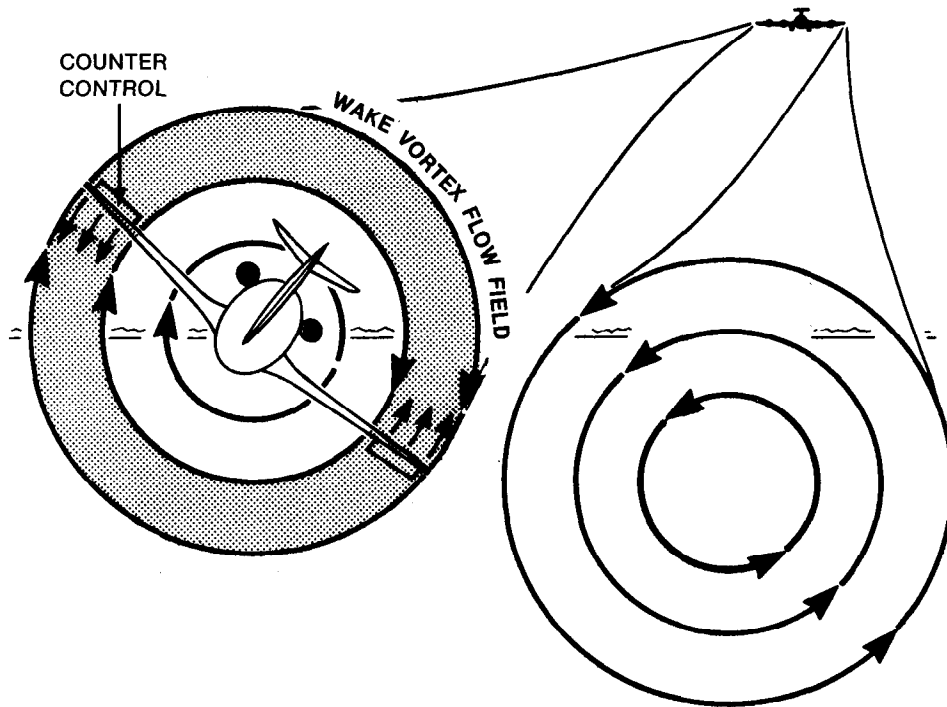

Figure 11

Appendix A

Wake Vortex Avoidance Systems

1. GENERAL

1.1 As a result of research and development a system for wake vortex avoidance has evolved. A straightforward approach was taken in the formulation of a system concept for wake vortex avoidance and it began with defining the system's users, the user requirements, and the operational requirements.

1.2 User interests and needs for wake vortex avoidance are diverse. In general, the users can be divided into three main groups:

- a) aerodromes;
- b) aircraft; and
- c) ATS.

1.2.1 Aerodromes require:

- a) an increase in runway capacity;
- b) maintenance of safety of operations;
- c) the minimization of system acquisition and ownership costs; and
- d) site independent system performance.

1.2.2 Aircraft needs are:

- a) to improve the safety of operations;
- b) to be operational under all weather and visibility conditions;
- c) to cover all aircraft;
- d) to have a low cost to obtain the use of the system; and
- e) to improve economics of operation.

1.2.3 ATS needs are:

- a) to maintain safety of operations;
- b) to optimize use of airspace and runways; and
- c) to have no interference with or degradation of other ATC functions.

1.3 Based on these needs, a wake vortex avoidance system should meet the following requirements:

- a) replace fixed wake vortex separation minima with separations adapted to individual cases, thus optimizing traffic flow;

- b) detect the presence of a vortex hazard and generate information necessary to avoid it;
- c) make the system ground-based. No additional avionics should be required to obtain the use of the system;
- d) use a modular system design, tailoring the system capabilities and cost to specific requirements;
- e) use a complement of ground instrumentation to ensure uniform system performance independent of site constraints;
- f) design the system for maximum independence from other ATS systems to ensure maximum system reliability; and
- g) use of the system shall not place any additional burden on air traffic controllers or pilots.

1.4 Fortunately, by their nature the possible solutions to the wake vortex problem lend themselves very well to the development of a modular system which meets all of the listed requirements. A series of systems of increasing complexity and cost are feasible, starting with the simplest, the vortex advisory system (VAS) and ending with the fully automated wake vortex avoidance system (WVAS).

2. THE VORTEX ADVISORY SYSTEM (VAS)

2.1 The VAS is the first step in the hierarchy of systems designed primarily to assist air traffic controllers in alleviating the wake vortex problem. The use of a VAS promises a significant gain in aerodrome capacity through reduced approach and departure times. Until recently the lack of knowledge about the life-cycle of wake vortices generated by today's large aircraft required large separation distances between successive aircraft and thus limited approach-and-landing capacities. Analysis of the extensive data on vortex behaviour as a function of meteorological conditions has shown a positive correlation between the vortex residence times and ambient wind conditions and has indicated that there are wind conditions which predictably remove vortices. A wind direction criterion could, therefore, be used to determine when standard or wake vortex separation minima should be used.

2.2 The VAS was designed to take advantage of the wind direction criterion. The system is based on comparing the

measured wind magnitude and direction (with respect to each runway heading) with the wind criterion. The comparison indicates via a simple display when wake vortex separations need no longer be applied.

2.3 The VAS was tested at Chicago O'Hare Airport (United States) to determine the feasibility of eliminating wake vortex separations when either the wake vortices have been blown out of the approach corridor, or the vortices have decayed and no longer present a hazard to the following aircraft. VAS testing was implemented by using an instrumentation system to measure the vortex positions as a function of time and the ambient meteorological conditions and correlating the vortex tracks with the VAS displayed output. The amount of time that the VAS indicated that wake vortex separation was not required was evaluated to determine how many additional operations could be accommodated if normal separations were in effect. The evaluation had to be performed under all combinations of approach and landing runway scenarios as well as under VFR and IFR weather conditions. It was anticipated that the system would allow the use of normal separations up to 60 per cent of the time, and that significant increases in capacity would be possible, especially during IFR conditions when current capacity was oversaturated.

3. THE VAS DISPLAYS

3.1 The system interfaces with the air traffic controllers via the VAS runway monitor display. The controller selects the operating corridor and designates either an arrival (A) or departure (D) runway. The display thereafter accepts data with the corresponding label from the data base. As a very important by-product, the controller display provides in digital form the wind direction, speed and gust in the selected region, thus greatly improving the accuracy of the wind information relayed to pilots by the controllers. The usual, centrally located single meteorological sensor does not provide accurate wind information for widely dispersed points. If arrivals are being handled by the controller, the display indicates red if vortex conditions require a three, four, five or six-mile separation between aircraft, or if an all three-mile, or whatever is the lowest permissible spacing, a green indication is shown. If departures are being handled, only the wind conditions are displayed, and the red/green indications are blanked out.

3.2 A separate summary display is provided for the supervisor's position console, which displays the meteorological conditions across the entire aerodrome as measured by the

surface wind sensor. This display should ease greatly the task of runway selection, and also show any major ambient wind anomalies requiring controller/pilot attention, such as major local wind changes resulting from the passage of a front or thunderstorm.

4. THE VORTEX WARNING SYSTEM (VWS)

4.1 The VWS is designed primarily to assist pilots to monitor a defined critical approach corridor, and to provide the pilot of a landing aircraft with information as to whether or not there are vortices present in the corridor.

4.2 A vortex sensor (a Ground Wind Vortex Sensing System (GWVSS), or a Doppler Acoustic Vortex Sensing System (DAVSS), etc. where there are terrain limitations), located approximately 600 m from the runway threshold, detects the vortices and tracks them in the critical approach corridor, and vortex-position information is displayed to the following aircraft via lights installed at the threshold of the landing runway.

4.3 Red and green lights can be used to indicate whether or not there are vortices present in the corridor. Green would indicate that the corridor is free of vortices. Red light patterns could be used to provide the pilot with advance information, enabling an early decision to continue approach or to initiate a go-around. Thus, a "rippling" red light line could indicate that vortex persistence of more than 60 seconds is expected in the corridor; steady red, less than 60 seconds.

4.4 The VWS has been tested operationally as a viable means of communicating to the pilot the corridor vortex status.

5. THE WAKE VORTEX AVOIDANCE SYSTEM (WVAS)

5.1 The ultimate solution to the wake vortex problem seems to combine VAS with VWS and developments in computer technology to produce a sophisticated WVAS with the capability to solve the wake vortex problems at certain aerodromes. Although the VAS has the potential, technically, to increase aerodrome capacity, its effectiveness varies and is governed by meteorological criteria. At Chicago O'Hare Airport, for instance, the prevailing wind conditions are such that the VAS has the potential to

increase capacity approximately 60 per cent of the time. However, this does not occur at all times. During the summer months when low winds prevail, normal separation can only be applied approximately 20 per cent of the time. The higher percentage occurred during the autumn and winter periods. Los Angeles International Airport by comparison, exhibited a wind pattern which resulted in the VAS being effective only 20 per cent of the time.

5.2 The WVAS incorporates the VAS and VWS concepts, but adds predictive capability to the system to provide adaptable separations, thus optimizing the traffic flow for any given conditions. The WVAS must obviously take up the slack between the VAS performance and the demonstrated capability for the air traffic system to operate with normal separations 99 per cent of the time. This can be achieved by a WVAS with the following techniques:

- a) use of a meteorological prediction algorithm with forecasting techniques to predict vortex conditions in the corridor approximately 20 minutes ahead. The predictive algorithm is driven by a network of meteorological sensors deployed about the aerodrome;
- b) use of a vortex behaviour predictive model incorporating all pertinent meteorological parameters and aircraft types. The actual vortex tracks measured by the vortex-detection system are then used to update the predictive algorithm;
- c) use of a VWS at each runway approach for fail-safe operation (vortex warning system, see 4);
- d) as opposed to a fixed separation standard, the WVAS provides an adaptable separation matrix which allows optimum separations and optimizes traffic flow for any set of conditions.

5.3 The WVAS thus has the potential to achieve greater utilization of the aerodrome capacity by the replacement of fixed separation standards with separations adapted to the prevailing situation, which permits maximum traffic flow. This achievement is made possible through the use of

accurate predictive algorithms and the fail-safe operations ensured by the presence of a VWS at each runway. Furthermore, the WVAS has a soft-failure mode. In the event of a main system failure, it reverts to a VAS and/or VWS operation. The WVAS thus has a high safety potential, technically, for providing approach control service. Its ultimate successful adaptation to the contingency-prone ATS systems would require an ultimate degree of executive control over such systems.

5.4 It is believed that the WVAS could allow aircraft spacing on approach of less than 3 NM and that the extensive data base shows that a 2 NM spacing could be used 86 per cent of the time. The adaptable separations provided by the WVAS would be continuously changed depending on traffic demand and meteorological conditions. The WVAS, therefore, would be used to its fullest capacity with the introduction of the metering-and-sequencing (M and S) algorithm into the automated radar environment. The separation requirements as calculated by the WVAS would then be directly inserted into the M and S system, the operation of which would be transparent to the controller, who, it is proposed, would only assume direct control in the event of equipment failure.

CONCLUSION

The studies undertaken by several States indicate that the use of vortex advisory system (VAS) or vortex warning system (VWS) could regain some of the runway capacity lost due to the increased wake turbulence separation minima. However, it has been found that the incidence of transitions through red/green warning lights do not provide sufficient time for the controller to change the separation minima applied between various types of aircraft in an already established approach sequence. Therefore, further research in this respect has been suspended.

Chapter 4

Surface Movement Guidance and Control

4.1 INTRODUCTION

4.1.1 In its broadest sense, surface movement guidance and control (SMGC) is the provision of guidance to, and the control of, all aircraft and ground vehicles on the movement area of an aerodrome. "Guidance" relates to equipment, information and advice necessary to enable the pilots of aircraft or the drivers of ground vehicles to find their way on the aerodrome and to keep the aircraft or vehicles on the surfaces or within the areas intended for their use. "Control" means the measures necessary to prevent collisions and to ensure that the traffic flows smoothly and efficiently.

4.1.2 An SMGC system provides guidance to, and control of, an aircraft from the landing runway to the parking position on the apron and back again to the runway used for take-off, as well as from the maintenance area to the apron, or vice versa. The system also provides guidance to, and control of, all ground vehicles whose functions require them to operate on the movement area, e.g. aerodrome management vehicles, aircraft servicing vehicles, rescue and fire fighting vehicles, and vehicles engaged in construction work. Additionally, an SMGC system assists in safeguarding against unauthorized or inadvertent entry onto operational runways.

4.1.3 An SMGC system comprises an appropriate combination of visual aids, non-visual aids, radiotelephony communications, procedures, control and information facilities. Systems range from very simple arrangements at small aerodromes with light traffic operating only in good visibility to very complex facilities at large and busy aerodromes with operations in very low visibility conditions.

4.1.4 The subject of SMGC is of a multi-disciplinary nature and as a result several ICAO Annexes and other documents contain provisions for many aids and procedures which are currently used for SMGC. However, the *Manual of Surface Movement Guidance and Control Systems* (Doc 9476) presents a review of the over-all requirements including details of systems recommended to meet various requirements.

4.1.5 Air traffic services (ATS) planners should consult the manual together with other relevant documents when developing aids and procedures to be used by ATS for the provision of SMGC service. In regard to the multi-disciplinary nature, it is most important that the work is performed on a co-operative basis within the various specialities involved. The ultimate aim is to develop an integrated system which is compatible with the requirements of all associated disciplines.

4.2 APRON MANAGEMENT SERVICE

The provision of surface movement control service on the manoeuvring area of an aerodrome is covered in Annex 11 by the specifications concerning aerodrome control service. Apron management service is a service provided to regulate the activities and the movement of aircraft and vehicles on the apron. With regard to the management of aircraft and vehicles on the apron, a variety of different methods are available depending on the particular conditions at an aerodrome. Apron management service may be provided by the aerodrome ATS unit, or by a unit set up by the aerodrome authority, or by the operator in the case of a company terminal, or by co-ordinated service between ATS and the aerodrome authority or operating company. Details concerning the different possible methods for the provision of the apron management service are included in the Manual of SMGC Systems.

4.3 SURFACE MOVEMENT RADAR

4.3.1 General

4.3.1.1 Surface movement radar (SMR) is one of the possible components of an SMGC system and may be used as an aid in the provision of aerodrome control service.

4.3.1.2 Specifications on the characteristics of SMR and its use do not exist in ICAO documents. SMR, like primary radar, is a stand-alone type system and does not warrant

the technical definition or co-ordination required by technically or operationally interdependent systems. Considering that each surface movement guidance and control system must be related to the operational conditions and requirements of the particular aerodrome (i.e. visibility conditions, traffic density and aerodrome layout), the system composition and capability are considered matters to be decided on an individual basis. SMR has proven to be useful in assisting with the monitoring of aircraft and vehicles on the manoeuvring area particularly in low visibility conditions.

Note.— See Annex 14, Volume 1, Chapter 8, for the requirements concerning the provision of SMR.

4.3.2 The role of SMR

4.3.2.1 There is currently no facility, or combination of facilities, that compensates fully for a controller's loss of visual contact with the aerodrome surface traffic. Information derived by other methods such as radiotelephony (RTF) communications or SMR is rarely comprehensive, and is far less economical in terms of the workload required for its acquisition. Due to the normally distant location of an aerodrome control tower from runways and taxiways, the controller's ability to control traffic on the manoeuvring area on the basis of visual observation will, during periods of reduced visibility, be limited. When such conditions of reduced visibility prevail, the air traffic control (ATC) workload per movement increases and the traffic handling capacity of the aerodrome control service may be reduced.

4.3.2.2 Provided that an aerodrome is adequately equipped with visual aids, the provision of an aerodrome SMR can make a valuable contribution to the safety and efficiency of the aerodrome surface movement control during periods of low visibility and at night; optimum capacity under these conditions is unlikely to be achieved without it. SMR permits a continuous check of runway occupancy and taxiway usage. Furthermore, it allows rapid appreciation of lighting control requirements and facilitates clearances for aircraft and vehicles. In emergencies it can play an important part in expediting movement of emergency vehicles and the safe disposition of other traffic.

4.3.2.3 At a major aerodrome, a large part of the manoeuvring area may be obscured at times from the aerodrome control tower while visibility is still within the limits at which traffic can operate at the normal level of demand, i.e. in visibility conditions sufficient for the pilot

to taxi and avoid collision with other traffic on taxiways and at intersections by visual reference, but insufficient for the aerodrome controller to exercise control and detect runway intrusions on the basis of visual observation. The introduction of SMR can to a great degree alleviate the limitations on observation and control normally associated with low visibility conditions; however, the workload involved in detailed monitoring, together with the clutter and other limiting factors, is very high and may therefore restrict the number of movements the aerodrome controller can handle at one time. Obviously, the accuracy of manoeuvres required on taxiways which can be satisfactorily accomplished by following lights and markings is far more precise than could be provided by ATC instructions using SMR guidance. It is necessary for the pilot to be able to comply with instructions given by the controller without the radar being used to provide directional guidance. However, the traffic and positional information a controller is able to provide by using SMR where it is provided as a component of the surface movement guidance and control (SMGC) systems is of major assistance to pilots operating on the manoeuvring area of an aerodrome.

4.3.2.4 In summary, SMR can make a valuable contribution to the safety and efficiency of aerodrome surface movement control in low visibility conditions and at night. However, it should be emphasized that SMR is an adjunct and not an alternative to the visual aids and procedures currently used for the control of aircraft and vehicles on the manoeuvring area.

4.3.3 Use of SMR

4.3.3.1 Aerodrome controllers determine the position of aircraft and vehicles on the manoeuvring area by visual observation and/or radio position reports. Within the limitation of the radar coverage, the information presented on an aerodrome SMR display may be used by ATC to supplement these existing methods as follows:

- a) to confirm that the runway is clear of aircraft, vehicles or obstructions prior to a departure or landing;
- b) to ensure that the departing aircraft is lined up on the correct runway;
- c) to ensure that the arriving aircraft has vacated the runway;
- d) to ascertain that the departing aircraft has commenced take-off run;
- e) to provide directional information to pilots or vehicle operators on request or as necessary;
- f) to monitor aircraft/vehicle compliance with control instructions on the manoeuvring area;

- g) to monitor the manoeuvring area and identify optimum taxiing routes that reduce congestion and assist in expediting the flow of traffic during periods of low visibility;
- h) to confirm a pilot or vehicle operator position report;
- i) to provide guidance information to emergency vehicles, as necessary;
- j) to assist in the timing of landing and take-off clearances in low visibility conditions to maximize runway utilization;
- k) to provide detection and guidance information to an aircraft uncertain of its position;
- l) to assist in detecting runway intrusions; and
- m) to ensure that approving of requested push-back will not conflict with traffic on the manoeuvring area.

4.3.3.2 SMR may be used to assist in conflict resolution at intersections and as an aid to assignment of intersection priorities where a possible conflict exists. This function should be performed by the issuance of appropriate holding instructions. Observation of the general traffic pattern and points of congestion on an SMR display should provide information to assist the controller in determining which aircraft should be given priority at an intersection.

4.3.3.3 SMR may be used to ensure that a runway is clear of traffic before clearance is given for a landing or take-off on that runway. An arriving aircraft leaving the runway should report "runway vacated" on the appropriate frequency. During periods of low visibility, however, it is sometimes difficult for the pilot to confirm that the aircraft is clear of the runway in use. SMR may, therefore, be used to verify a "runway vacated" report from the pilot. An aircraft which is approaching a runway on an intersecting taxiway and has been given an instruction to hold should be monitored on the SMR to confirm compliance. Intersecting runways may be monitored on the SMR for possible conflicts prior to clearing aircraft for take-off or landing.

4.3.3.4 SMR may be used to ensure that a departing aircraft has taxied into position for take-off on the proper runway. Such a check is particularly important when two close parallel runways are in use and an arriving aircraft is on final approach for landing on the adjacent runway.

4.3.3.5 Runway utilization during periods of low visibility can be significantly improved through the use of SMR for those runway configurations that involve interaction of arriving and departing traffic during take-off or landing. Anticipation of the runway turn-off by an arriving aircraft can be gained through SMR. Compliance with "line up and wait" instructions to departing aircraft,

commencement of take-off roll and lift-off can be monitored on SMR. Use of SMR can significantly assist in seizing opportunities for the release of departing aircraft in between arriving aircraft during low visibility conditions whenever runways are used for both arrivals and departures.

4.3.4 Limitations of SMR

4.3.4.1 Any of the following technical limitations may affect the operational efficiency and use of SMR:

- a) aircraft/vehicle size — detectability diminishes with reduction in size;
- b) line-of-sight limitations;
- c) heavy rain causing clutter and resolution difficulties;
- d) shielding — a portion of an aircraft/vehicle may be shielded from the radar by another part of the same object, e.g. an offside wing is often not visible when shielded by the fuselage;
- e) reflection — other aircraft/vehicle(s) and large structures such as hangars may reflect some energy away from the radar antenna, e.g. a smooth aircraft fuselage at angles other than a right angle to the radar;
- f) rough surfaces or long grass — vehicle detectability is reduced on rough ground, wet or long grass;
- g) radar position elongation — occurs in both range and azimuth, due to radar equipment resolution limitations associated with stronger returns; and
- h) lack of radar position labels and symbols.

4.3.4.2 SMR should not be used by ATC to provide heading instructions for taxi guidance. Taxi guidance instructions using SMR should be the same as those applicable for visual control.

4.3.4.3 The workload and concentration involved in detailed SMR monitoring are significant and can restrict controller traffic handling capacity.

4.3.5 Methods of establishing SMR identification

4.3.5.1 Before providing guidance to an aircraft/vehicle based on SMR-derived position information, positive radar identification should be established by the use of at least one of the methods specified below:

- a) correlating the position of a visually observed aircraft/vehicle to that displayed by SMR;

- b) correlating an identified SMR position observed from another radar source;
- c) correlating an SMR position complying with an ATC instruction for a specific manoeuvre;
- d) correlating a displayed SMR position to an aircraft or vehicle as reported by radio;
- e) correlating a displayed SMR position to an aircraft or vehicle position:
 - 1) entering a runway or taxiway intersection;
 - 2) abeam a building or airfield feature which either shows as a permanent echo on the display, or is marked on the video or grid map; and
 - 3) on a taxiway or runway, provided that there are no other unidentified vehicles or aircraft on that runway or taxiway segment.

4.3.6 Relay of SMR position identification

Positive identification of an SMR-derived aircraft/vehicle position may be relayed by use of the following methods:

- a) direct designation; or
- b) specifying the location of the SMR-derived position by reference to identifiable features displayed on the video or grid map.

4.4 RESPONSIBILITIES AND FUNCTIONS

4.4.1 At certain aerodromes, control of aircraft on the apron is not the responsibility of ATS units. At these aerodromes, there should be a designated body responsible for ensuring the safe movement of aircraft on the apron.

4.4.2 At aerodromes equipped with an aerodrome control tower, where the task of providing SMGCS has been assigned to the aerodrome control tower (Annex 11, 3.2 refers), the operational responsibility for co-ordinating the movement of aircraft on the movement area belongs to the appropriate ATS unit. At aerodromes which are not equipped with a control tower, limited information may be provided by an aerodrome flight information service (AFIS).

4.4.3 The appropriate ATS unit and/or aerodrome authority should be aware of the need to monitor the SMGC system and to have any failures corrected as soon as possible. The monitoring may take the form of visual surveillance of lights, including reports from pilots, and of electronic monitoring of the electrical and electronic components of the system.

4.4.4 The appropriate ATS unit is normally responsible for operating the visual components of the system, including stop bars, taxiway centre line lights and routing designators.

AIR TRAFFIC SERVICES PLANNING MANUAL

PART III

FACILITIES REQUIRED BY ATS

AIR TRAFFIC SERVICES PLANNING MANUAL

PART III

**SECTION 1. GROUND BASED NAVIGATION, SURVEILLANCE
AND COMMUNICATIONS EQUIPMENT**

SECTION 1

GROUND BASED NAVIGATION, SURVEILLANCE AND COMMUNICATIONS EQUIPMENT

Contents

	<i>Page</i>		<i>Page</i>
Chapter 1. General	III-1-1-1		
1.1 Introduction	III-1-1-1		
1.2 Cost-benefit considerations	III-1-1-1		
1.3 Types of equipment associated with ATC services	III-1-1-3		
Chapter 2. VOR/DME and TACAN	III-1-2-1		
2.1 Functional requirements	III-1-2-1		
2.2 Operational application	III-1-2-2		
Chapter 3. Non-directional Radio Beacon .	III-1-3-1		
3.1 Functional requirements	III-1-3-1		
3.2 Operational application	III-1-3-1		
Chapter 4. Long-range Radio Navigation Aids	III-1-4-1		
4.1 Functional requirements	III-1-4-1		
4.1.1 General	III-1-4-1		
		4.1.2 OMEGA	III-1-4-1
		4.1.3 LORAN-C	III-1-4-3
		4.2 Operational application	III-1-4-4
		Chapter 5. Landing Systems	III-1-5-1
		5.1 Functional requirements	III-1-5-1
		5.1.1 Instrument landing system	III-1-5-1
		5.1.2 Microwave landing system	III-1-5-2
		5.2 Operational application	III-1-5-3
		5.2.1 Instrument landing system	III-1-5-3
		5.2.2 Microwave landing system	III-1-5-3
		Appendix A. General procedures used in the United States for the control of aircraft in ILS critical areas	III-1-5-4
		Chapter 6. VHF Direction Finder	III-1-6-1
		6.1 Functional requirements	III-1-6-1
		6.2 Operational application	III-1-6-1

Chapter 1

General

1.1 INTRODUCTION

1.1.1 To function properly, an air traffic control (ATC) system requires various items of equipment. Types and quantities of this equipment will vary with the properly justified demands on the particular system.

1.1.2 Equipment elements should generally be installed in stages and in proportion to the increase in demand(s) imposed on the air traffic services (ATS). Such phasing has the advantage of reducing the immediate economic burden imposed on administrations by spreading system establishment or expansion costs over a longer time. It also reduces the critical effect of time on personnel recruitment, selection and training necessary for equipment installation, maintenance and operation.

1.1.3 In addition to the pure equipment costs, there are many "hidden" costs associated with the acquisition of major items of ATC equipment. Hidden costs include personnel salary and allowance costs associated with the preparatory work and the procurement, installation, operation and maintenance of the equipment. It is therefore essential that relevant hidden costs be included in the preparation of initial budgetary estimates.

1.1.3.1 Activities, materials and other elements which are associated with hidden costs may include:

- a) site survey — selection of the best site for optimum operational benefit from the equipment, commensurate with ecological considerations and consistent with budgetary limitations;
- b) site acquisition — rights to the property including protection against future neighbouring encroachments (e.g. growing trees, other structures or electronic interference) which could adversely affect the performance of the equipment; rights to ensure appropriate site access throughout the predicted life of the equipment;
- c) site preparation — foundations, clearing, etc., and shelter for the equipment and the maintenance personnel against the meteorological conditions common to the location; similar protection against

catastrophes which could be expected to occur at that location (e.g. earthquake, landslide, flood, washout, etc.); provision of utilities including the required degree of reliability; site access improvement as needed (e.g. power lines and access roads);

- d) preparation of equipment specifications — an equipment specification is prepared either as a functional specification or as a technical specification:
 - 1) a functional specification describes the purpose the equipment is expected to serve and the terms of desired performance, i.e. operational needs, maintainability, reliability, durability and useful life, etc. It gives the potential supplier information on how, or what equipment, he will need to produce in order to satisfy the specified functional performance requirements;
 - 2) a technical specification describes the detailed engineering (physical, mechanical, electronic) aspects of the components making up the equipment in question;
- e) contract negotiation;
- f) equipment inspection(s) before technical acceptance;
- g) installation;
- h) systems evaluation (operational acceptance) including flight inspection costs for aircraft and crew;
- i) ancillary monitor equipment;
- j) standby equipment and/or fail-safe or fail-soft provisions;
- k) spare parts inventory or suitable alternative(s) such as rapid, reliable replacement from a centralized source;
- l) special tools required for maintenance of that equipment;
- m) training for operations and maintenance personnel;
- n) manuals of the operation and maintenance of the equipment.

1.2 COST-BENEFIT CONSIDERATIONS

1.2.1 When considering the acquisition of expensive equipment, the use of cost-benefit methodology may be desirable to help in determining budget justification for

new equipment. The cost-benefit method described in the following paragraphs lists some of the elements which should be considered in this respect. The method has been used successfully but the elements listed here are neither all-inclusive nor does each of them merit inclusion in the equation in every case. Pre-operation costs have, to a large measure, been listed in 1.1.3.1 above. When added to the pre-operation cost outlay, the equipment price as agreed in the contract with the supplier, plus the anticipated continuing operations and maintenance costs (personnel remuneration, utilities, etc.) give the total "cost" portion of the equation. If these estimated costs are within the budgetary limitations, then the "benefit" portion of the equation should be developed.

1.2.2 Benefits derived from additional ATC equipment may be categorized by any one of the following: increased productivity, efficiency, safety and/or environmental improvements. As is done for the costs, the benefits are normally determined for the life cycle of the equipment.

1.2.2.1 Productivity can be measured in terms of how many more operations are expected to be handled with the improvement than without it. From this, one derives how many controllers expected to be leaving the service do not need to be replaced, or how many additional controllers need not be hired to satisfy increased demands on ATS. Cost-saving or cost-avoidance is then quantified by multiplying the cost per controller times the number of controllers not replaced or not hired (due to the new equipment). Calculated for the equipment life, this is the benefit for this element.

1.2.2.2 Productivity in the control environment may also be obtained by the elimination or reduction of non-control tasks which nonetheless contribute to the system, e.g. automatic instead of manual preparation of flight progress strips. The remuneration costs for the personnel whose functions will then be eliminated or substantially reduced are then added to the benefit column of the equation.

1.2.2.3 Productivity related to replacement of maintenance personnel and/or to additional equipment is measured by its predicted maintenance time (number of scheduled and non-scheduled outages over a fixed period of time, multiplied by the average time per outage). The time so obtained is then compared with actual maintenance time as experienced with the equipment which is intended to be replaced or supplemented. Where this comparison is in favour of the new or additional equipment the differential is multiplied by the maintenance personnel remuneration cost, which results in the benefit quantification for this element.

1.2.2.4 Where an efficiency improvement is expected by the use of more direct routings, the time saved per aircraft, multiplied by the aircraft cost per unit of time, multiplied by the anticipated number of such flights over the lifetime of the equipment under consideration provides the "efficiency" benefit.

1.2.2.5 Where the additional equipment permits a reduction of ATC delays because of the following, the reductions are considered as time savings and computed as in 1.2.2.4 as an efficiency benefit:

- a) the use of lower landing minima (thus avoiding holding or a diversion to an alternate aerodrome); or
- b) the use of lower departure minima; or
- c) the use of reduced separation and a resulting higher rate of arrivals and/or departures; or
- d) the implementation of an improved ATS route structure (e.g. parallel routes).

1.2.2.6 Where the reductions in operating time obtained in accordance with the provisions in 1.2.2.4 and 1.2.2.5 above relate to commercial operators, the average number of business travellers per affected flight and the economic value of such travellers' time should be available from the operators concerned. These factors are then treated as described in 1.2.2.4. The result is added to the "benefit" column.

1.2.2.7 It is difficult to quantify "safety", since it is virtually impossible to agree on the material value of a human life. However, an approximation for the safety benefit may be obtained by assessing the probable reduction in aircraft accidents attributable to the new equipment. This is then multiplied by the probable number of fatalities (based on historical data) and this, in turn, is multiplied by a reasonable (national) assessed value for a life (insurance companies may be a logical source for such a value). This total is then extrapolated for the life cycle of the equipment in question and the end product represents the "safety" benefit value.

1.2.2.8 Environmental improvement cannot be easily quantified in economic terms; however, a reasonable broad-based assessment is possible. A review of the properties on the ground which are overflowed with existing arrangements and its comparison with those overflowed as a result of new routings, made possible through the new equipment, would provide a basis for such an assessment. Demographic comparisons of the two areas could then be made with special reference to numbers of people, hospitals, schools and private residences and values could be assigned to personal health, quiet enjoyment and duration of exposure. When these values are integrated with the data

from the demographic comparisons, any favorable differences should then be added to the benefit column. Similarly, loss or gain values could be assigned to the two areas of real estate involved and a net favourable difference should also be added to the “benefit” side.

1.2.2.9 Replacement equipment may also be more reliable. Any benefits derived from this fact may take several forms. More reliable communications and/or radar will induce the controller to adhere more closely to minimum and thus more efficient separation standards, while, with less dependable equipment, the controller will tend to apply larger separations for reasons of safety. This benefit is, however, too indefinite to be quantified but should be referred to in narrative terms on the “benefit” side. In addition, increased reliability should reduce maintenance efforts (see 1.2.2.3 above) and may permit more dependable commercial air carrier operation which, in turn, may encourage an increasing number of passengers to elect to travel by air. This intangible fact should also be included in the narrative accompanying the benefit material.

1.2.2.10 Further to the considerations in 1.2.2.4 and 1.2.2.5, reliability may enhance air defence capability. If this is the case, it should also be mentioned in the benefit material, even though economic values cannot be assigned to such benefit.

1.2.3 Whenever the total benefit, as expressed in material terms alone or together with those benefits described in narrative form, is found to be higher than the costs, it

should be considered as substantial support for a decision to proceed with the necessary steps for procurement of the equipment item in question.

1.3 TYPES OF EQUIPMENT ASSOCIATED WITH ATC SERVICES

1.3.1 Major types of equipment associated with ATC services include:

- a) very high frequency omni-directional range (VOR);
- b) non-directional radio beacon (NDB);
- c) long-range radio navigation aids;
- d) communication equipment;
- e) primary and secondary radar;
- f) radar presentation equipment;
- g) automated systems;
- h) instrument landing system (ILS);
- i) very high frequency direction-finding (VDF).

1.3.1.1 The respective functional and operational requirements for the equipment listed above are discussed in the following chapters, with the exception of primary and secondary radar, radar display equipment and automated systems (e) to g) above). It was believed advantageous to deal with the functional and operational requirements of this equipment together with the use made of it because of the close interrelation which exists between these two aspects of such equipment (Part II, Section 3, Chapters 2 and 3 refer).

Chapter 2

VOR/DME and TACAN

2.1 FUNCTIONAL REQUIREMENTS

2.1.1 The VHF omnidirectional radio range (VOR) is an omnidirectional (360° of azimuth) range station which operates in the very high frequency (VHF) band of the radio spectrum between 108 to 118 MHz, sharing the band from 108 to 112 MHz with the localizer component of instrument landing systems (ILS). Since it is normally used within approximately 130 NM of the station, the VOR is considered a short-range navigation aid. VORs are used at times beyond 130 NM; however, the accuracy of navigation guidance derived from it decreases with increased range. The basic navigation guidance derived from a VOR is a radial line of position (magnetic) with respect to a known geographic point (the VOR site). The radial line is read in degrees of azimuth from magnetic North and is technically accurate to within $\pm 2.0^\circ$. The over-all system accuracy is $\pm 5.0^\circ$ (see Part I, Section 2, Chapter 5, Appendix B). Bearing information may be used by aircraft to fly toward or away from the station at any azimuth selected by the pilot. The 180° ambiguity in this indication is resolved by the provision of a “to/from” (the VOR) indicator in the aircraft avionics.

2.1.2 The identification of specific VORs is provided by means of a Morse Code identifier or by voice recording. The VOR may also be provided with a voice channel for ground-to-air communications. VORs can be remotely operated by the use of telephone lines from the control facility. Where standby or dual equipment is provided, an automatic transfer between the equipment is made whenever the operating VOR is subject to malfunction. In case of malfunction of a VOR and/or in case the VOR signal received by the aircraft is not adequate to give reliable navigation guidance, a visual alert is triggered in the cockpit display, e.g. a warning flag appears on the airborne receiver indicator.

2.1.3 The VOR is subject to line-of-sight limitations; that is to say that its signals can only be received at increasingly higher altitudes as the distance of the aircraft from the station increases. The usable range of a VOR is also proportional to its power, i.e. the greater the power output,

the greater the effective range. In addition, VORs are subject to co-channel or adjacent channel frequency interference problems with other VORs or ILS localizers if care is not taken in the frequency assignment planning made for these aids.

2.1.4 When overflying the VOR, aircraft will enter a “cone” of signal “softness” but its horizontal dimension at any level is relatively small and has, therefore, normally no noticeable effect on navigation. The ratio of altitude to horizontal “soft” signal distance is probably less than 1.7 to 2; for example, at 1 700 ft above the station, irresolution will exist, at most, for 2 000 ft longitudinally.

2.1.5 A Doppler VOR (DVOR) is an improved, but more expensive version of the VOR. It has the advantage of being able to overcome many electronic interference problems of a particular site. DVORs are, as a rule, also more precise than the basic VOR. The precision VOR (PVOR), a modified DVOR, is significantly more precise than a VOR or DVOR, but it is still more expensive. Its use of DVOR is clearly advantageous in all those cases where very accurate track guidance is required by aircraft. A terminal VOR (TVOR) is a low power (50 W) VOR used for terminal navigation guidance.

2.1.6 Distance measuring equipment (DME) is a useful adjunct to, and is normally collocated with a VOR. In such cases, the VOR is referred to as “VOR/DME”. DME is also subject to line-of-sight limitations, but is normally usable up to 200 NM at appropriate levels. A DME provides a continuous digital readout of the slant-range distance, in nautical miles, between the aircraft and the DME site. It is a rather precise aid, the slant distance accuracy being $\frac{1}{2}$ NM or 3 per cent of the distance, whichever is greater. Slant range differs from horizontal distance when projected onto a plane, the former being always larger, and the difference will be greatest when aircraft are at their highest level directly over the station. When using a VOR/DME, the tuning of the airborne receiver to the VOR will automatically couple the DME receiver to the associated DME ground station. DME operates in the ultra-high frequency (UHF) band between

962 MHz and 1 213 MHz. This band is relatively free of interference from atmospheric and precipitation static.

2.1.7 Tactical air navigation (TACAN) is a military development providing both the azimuth and distance components by equipment operating in the UHF band. Where a TACAN is collocated with a VOR, the distance measuring component of the TACAN substitutes for and fulfils any civil requirement for DME. The VOR is then referred to as "VORTAC". As with DME, tuning to the VOR will automatically interlock with the associated TACAN distance measuring element. When used by civil aircraft, the guidance derived from a VOR/DME and a VORTAC is identical.

2.2 OPERATIONAL APPLICATION

2.2.1 The VOR/DME is the basic short-range aid used to provide navigation guidance along airways, air traffic services (ATS) routes and specified tracks. Its accuracy allows ATS routes to be kept at reasonable widths and permits the application of comparatively small lateral

separation criteria between routes, resulting in a more efficient use of the airspace.

2.2.1.1 The VOR/DME route structure is normally established so as to make it possible for aircraft to fly from one VOR direct to the next, or along intersecting radials of two adjacent VORs. Reporting points and/or other significant points are normally established along radials, either together with a given DME distance from an associated VOR, or by an intersection of radials from two different VORs and change-over from one VOR to another is normally made at the mid-point between the two VORs concerned.

2.2.1.2 The TVOR can serve as a landing aid at locations where no precision approach facility (ILS, precision approach radar (PAR)) is available. Where required by the local situation, it may also be provided with a collocated DME in order to provide improved guidance along the approach path.

2.2.1.3 Where standard instrument departure (SID) and standard arrival (STAR) routes have been established to facilitate the flow of departing and/or arriving air traffic these are frequently based on VOR/DMEs and TVORs (see Part I, Section 2, Chapter 4, 4.4).

Chapter 3

Non-directional Radio Beacon

3.1 FUNCTIONAL REQUIREMENTS

3.1.1 Non-directional radio beacons (NDB) transmit non-directional signals in the low and medium frequency (L/MF) bands, normally between 190 to 1 750 kHz. With appropriate airborne equipment, the pilot can determine the bearing of the station, or can “home” on the station. The specific identification of an NDB is normally broadcast in Morse Code.

3.1.2 Although NDBs are comparatively inexpensive navigation aids and relatively simple to install and maintain, they have significant drawbacks. Bearing information derived from NDBs is not very precise and lightning, precipitation static, etc., cause intermittent or unreliable signals resulting in erroneous bearing information and/or large oscillations of the radio compass needle. At night, since L/MF radio wave propagation increases, the radiation patterns of NDBs are subject to considerable but unpredictable variations which might result in interference from distant L/MF stations which can render navigation with this aid difficult. Nearly all disturbances which affect the bearing radiation output also affect the facility identification. Usually noisy identification occurs when the automatic direction-finder (ADF) needle of the radio compass in the aircraft behaves erratically; voice, music, or erroneous identifications will usually be heard and a false bearing will be displayed on the radio compass. Since ADF receivers do not have a “flag alarm” to warn the pilot when erroneous bearing information is

being displayed, the pilot must continuously monitor the NDB's identification.

3.2 OPERATIONAL APPLICATION

3.2.1 NDBs continue to be used as air navigation aids despite the availability of improved aids, e.g. VHF omnidirectional radio range (VOR), and the deficiencies described in 3.1.2. This appears to be mainly due to the fact that, in many cases, NDBs were installed before the VORs became available and because NDBs are, even now, so much less costly to install and maintain. Where operating, NDBs are mainly used:

- a) as a non-precision instrument approach aid (by itself); or
- b) in conjunction with an instrument landing system (ILS) (then designated as a “locator”); or
- c) to define L/MF routes/airways, etc.

3.2.2 When NDBs are used to define L/MF routes/airways, etc., they are normally operated as short-range aid. However, the power output is raised significantly when the NDB is serving as a landfall point used to define an “off-shore” or similar route.

3.2.3 The effective range of an NDB is proportional to its power output. NDBs with a power output of less than 25 W are classified as “compass locators” and their effective range does not exceed 15 NM during day time.

Chapter 4

Long-range Radio Navigation Aids

4.1 FUNCTIONAL REQUIREMENTS

4.1.1 General

For universal application, a navigation system should provide accuracy, low cost, high availability and broad coverage. Since no single type of navigation aid meets all of these requirements, diversification has become a necessity. The very low frequency (VLF) navigation aids, (e.g. OMEGA, LORAN-C), with their more extensive coverage are better suited than very high frequency (VHF)/ultra high frequency (UHF) aids (e.g. VHF omnidirectional radio range (VOR)/distance measuring equipment (DME)) to meet current long-range navigation requirements. Although VHF/UHF facilities contribute greater navi-

gational accuracy (at a cost of significantly less signal range) recent developments with OMEGA have shown that the accuracy requirements are now being met to a satisfactory degree.

4.1.2 OMEGA

4.1.2.1 OMEGA is a VLF (10 to 14 kHz) circular or hyperbolic navigation system whose propagation characteristics are such that eight strategically located transmitting stations will provide world-wide coverage. The eight stations now in operation are located in Norway, Liberia, Hawaii (United States), North Dakota (United States), Argentina, Japan, La Réunion (France) and Australia (see Figure 1).

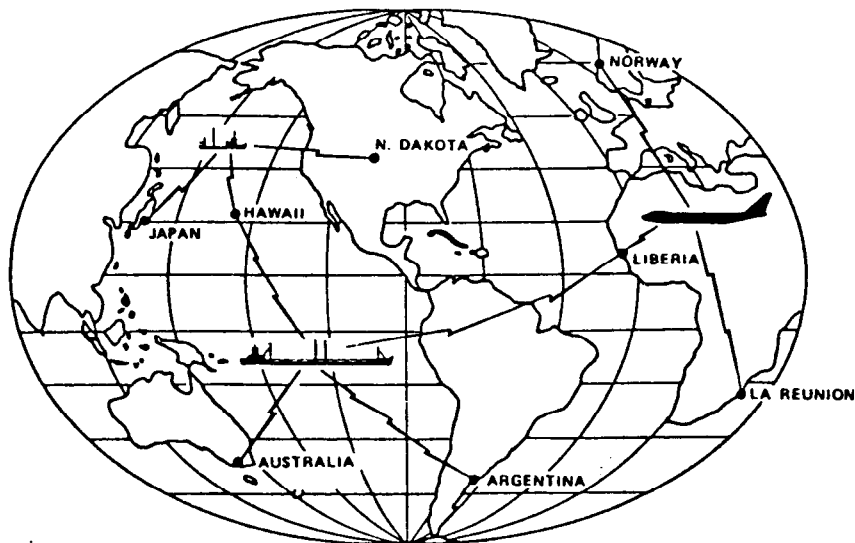

Figure 1.— OMEGA transmitter locations

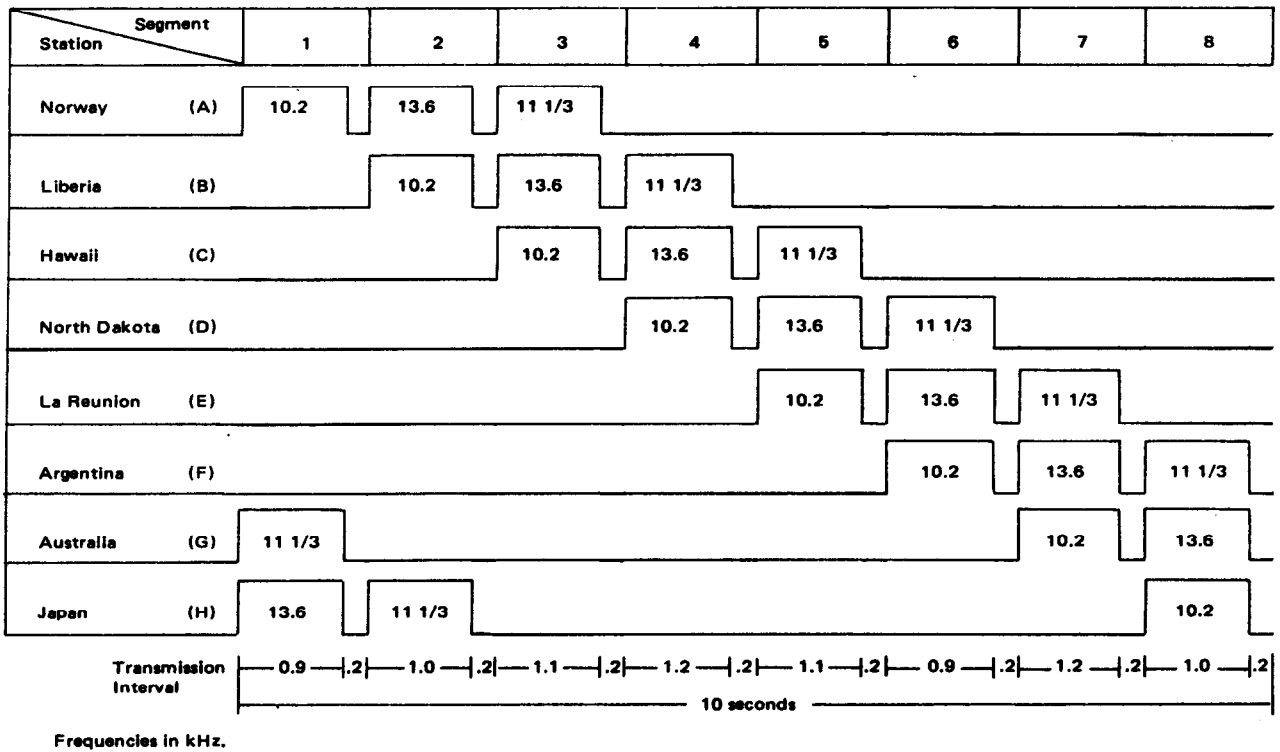

Figure 2.— OMEGA transmission pattern

4.1.2.2 The existing OMEGA navigation system provides coverage over more than 90 per cent of the earth's surface, including virtually the entire Northern Hemisphere. OMEGA stations transmit omnidirectional, continuous wave (CW), coded and precisely timed signals. Each station transmits on four specified, basic, navigation frequencies in sequenced format. This time-sequenced format prevents inter-station signal interference. The pattern is arranged so that during each transmission interval only three stations are radiating; each at one of four different basic frequencies (see Figure 2). With eight stations and a silent interval of 0.2 s between each transmission, the entire cycle is repeated once every 10 s. An OMEGA station is operating in full format when the station is transmitting on the basic frequencies plus the unique frequency.

4.1.2.3 Each OMEGA transmitter has a range of about 5 000 NM. The range will vary since it is dependent upon noise (from lightning discharge), the frequency and intensity of which change with latitude, season and time of day. Propagation over the ocean suffers the least attenuation while propagation over areas covered with ice is most affected. It is for this reason that the best coverage is obtained over oceanic areas. In addition, at night the range of individual stations is generally increased, thus improving the use of the system.

4.1.2.4 The airborne receiving equipment computes a line of position (LOP) based on the phase difference between signals received from two transmitter stations. Using a minimum of three stations, the receiver computes at least two LOPs and the intersection of these two defines the aircraft position. The current position accuracy obtained with OMEGA is 2 to 4 NM. It is expected that this accuracy can be further improved when the system is completed. Position accuracy derived from OMEGA may be better at the end of a flight than at the beginning due to more favourable propagation conditions, i.e. errors may be time-dependent since signal reception by aircraft is often a function of the time of day. Heights of specific layers in the earth's ionosphere and their degree of ionization vary (see Figure 3), a condition which affects the sky-wave corrections and consequently results in decreasing accuracy of the system. Accuracy will be improved, however, with better sky-wave correction prediction. Another limitation of OMEGA is that signals from a particular station should normally not be used within a 600 NM (about 1 000 km) radius of that station, and this radius limitation is greater at night. Such a limitation is, however, not very significant since each transmitter has a useful range of about 5 000 NM, and aircraft can generally receive signals from at least 3 stations; the consequence of possibly using long baselines considerably increases the accuracy.

4.1.2.5 In the USSR a long-range navigation system similar to OMEGA is used. The Russian system has transmitters located within its territory (contrary to OMEGA); one full transmission cycle takes, however, only 3.6 s. This rapid data transmission rate is likely to be even more valuable for aviation.

4.1.3 LORAN-C

4.1.3.1 Long-range navigation (LORAN-C) is the improved version of the LORAN navigation system. It is a pulsed, hyperbolic system operating in the frequency band from 90 kHz to 110 kHz. Three or more transmitting stations are set up in chains in which the master station and its associated slave stations can be separated by up to 800 NM.

4.1.3.2 The LORAN-C receiver computes LOPs based on time-of-arrival differences between signals from selected combinations of two transmitters of the same chain, one of which must be the master station. The aircraft position is at the point where these LOPs intersect. LORAN-C chains provide geographic coverage ranging from 900 to 2 400 NM by means of their ground-wave signals.

LORAN-C does not provide world-wide coverage, although its (sky-wave) signals are used in northern latitudes by some trans-oceanic flights. The ground-wave range of the LORAN-C transmitter is generally less than 1 200 NM; the one-hop sky wave, less than 2 300 NM; the two-hop sky wave, up to 3 400 NM. Between 1 200 and 1 800 NM from the stations used, the ground wave is sometimes received, but this reception is unpredictable.

4.1.3.3 Sky waves normally provide a stronger signal to the LORAN-C receiver, but these signals should only be used when no ground wave signal is received because each LORAN line on the chart represents a difference in arrival time of two ground waves. The sky-wave correction is only an approximation, since the height of the reflecting layer varies (see Figure 3). Thus the system accuracy is 0.25 NM in published areas of ground wave coverage, whereas with the use of sky-wave signals the position error is of the order of 2 NM.

4.1.3.4 LORAN-C signals are available continuously regardless of the time of day or weather conditions, and the system has a record of very high reliability. Over the years

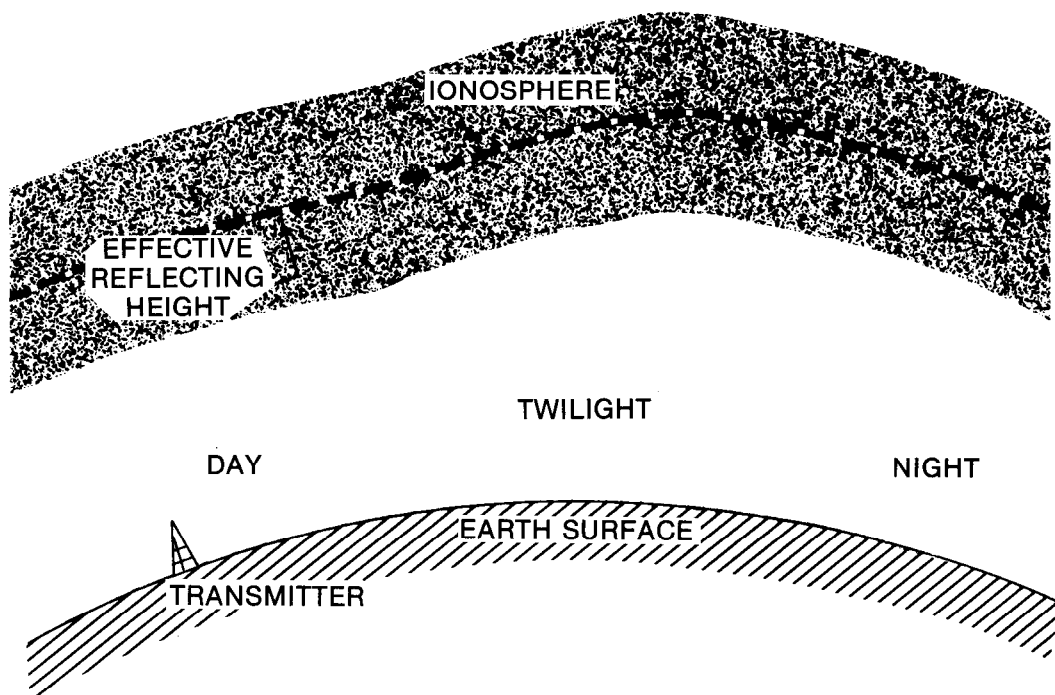

Figure 3.— Earth-ionosphere relationship

of operation of this system very few outages have occurred and these have been of very short duration.

4.2 OPERATIONAL APPLICATION

LORAN-C offers medium to high accuracy in position determination over an extended range. OMEGA offers even greater range, i.e. world-wide coverage, but with a lesser degree of accuracy. LORAN-C and OMEGA are the

major, ground-based systems providing navigation coverage over wide areas. OMEGA will continue in operation, due to its international civil character, coverage and economy of user equipment. LORAN-C will continue in operation because of its predictable and repeatable accuracy within its area of coverage and due to the economy of user equipment. However, its operation will be restricted to specific areas because its extension so as to provide world-wide coverage would pose prohibitive ground equipment costs. When using both OMEGA and LORAN-C, the user has a purely passive function. He does not transmit any signal for position fixing and, because of this, the systems are never saturated and the number of users is unlimited.

Chapter 5

Landing Systems

5.1 FUNCTIONAL REQUIREMENTS

5.1.1 Instrument landing system

5.1.1.1 The instrument landing system (ILS) is the ICAO standard, non-visual aid to final approach and landing. Ground equipment consists of two highly directional transmitting systems and two marker beacons aligned along the approach. A third marker beacon may be added along the approach path if operationally desirable. The directional transmitters are known as the localizer and glide slope transmitters. The total landing system of which ILS is an integral part generally provides the pilot with:

- a) guidance information regarding the approach path derived from the localizer and the glide slope;
- b) range information at significant points along the approach path by marker beacon or continuous range information from distance measuring equipment (DME); and
- c) visual information in the last phase of flight from approach lights, touchdown and centre line lights, runway lights.

5.1.1.2 At selected locations where the provision of marker beacons at the defined locations creates difficulties, they may be replaced by a DME which is associated with the ILS. This provision is particularly advantageous when approaches have to be made over water. At some locations a complete ILS system is provided for each landing direction of a runway, or for a number of runways. When such is the case, only one of the ILS systems is, however, put in operation at any time.

5.1.1.3 The localizer transmitter, operating on one of the 40 ILS channels within the frequency band from 108 MHz to 112 MHz, emits signals which provide the pilot with course guidance onto the runway centre line. The approach course of the localizer, which is used with other components, e.g. glide slope, marker beacons, etc., is called the front course. The localizer signal emitted from the transmitter site at the far end of the runway is confined within an angular width between 3° and 6°, depending on the

distance of the localizer site from the approach threshold, so as to provide a linear signal width of approximately 210 m (700 ft) at the runway approach threshold. The course line along the extended centre line of a runway, in the opposite direction to the approach direction served by the ILS is called the back course. Back course signals should not be used for conducting an approach unless a back course approach procedure has been published for the particular runway and is authorized by ATC. The identification of an ILS is transmitted in International Morse Code and consists of a two or three-letter identifier starting with the letter I (· ·). It is transmitted on the localizer frequency. Category I and II (see Part II, Section 5, Chapter 2) localizers may provide a ground-to-air communication channel.

5.1.1.4 The localizer provides course guidance throughout the descent path to the runway threshold from a distance of 18 NM from the antenna between a height of 300 m (1 000 ft) above the highest terrain along the approach path and 1 350 m (4 500 ft) above the elevation of the antenna site. Distinct off-course indications are provided throughout the areas of the operational service volume as shown in Figure 1. These areas extend:

- a) 10° either side of the course within a radius of 18 NM from the antenna;
- b) 35° either side of the course within a radius of 10 NM from the antenna.

5.1.1.5 The ultra high frequency (UHF) glide slope transmitter, operating on one of the 40 ILS channels within the frequency band from 329.15 MHz to 335 MHz, radiates its signals only in the direction of the localizer front course. However, in some cases where a back course approach procedure has been established an additional glide slope transmitter has been installed to radiate signals in the direction of the localizer back course to provide vertical guidance for this approach procedure. Where this is done, the two glide slope transmitters will operate on the same channel but are interlocked so as to avoid simultaneous operation and ensure that either the front course or the back course is provided with vertical guidance but not both at the same time.

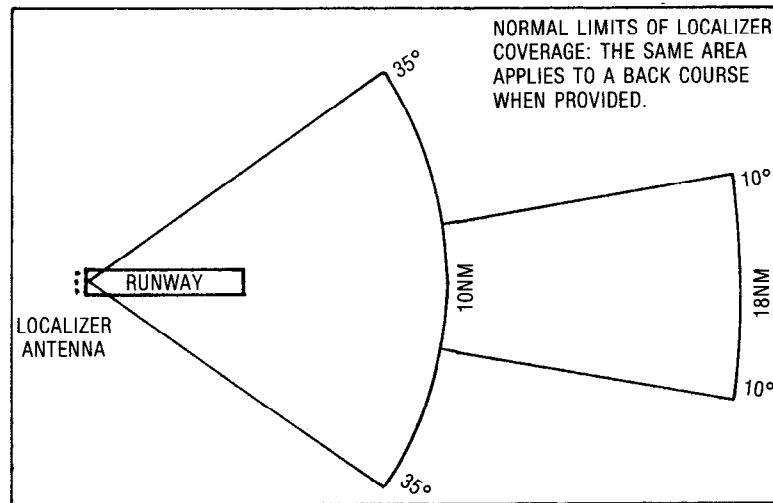

Figure 1

5.1.1.6 The glide slope transmitter is located between 230 m (750 ft) and 380 m (1 250 ft) from the approach end of the runway (down the runway) and offset between 75 m (250 ft) and 198 m (650 ft) from the runway centre line. It transmits a glide path with a beam width of 1.4° ("glide path" means that portion of the glide slope that intersects the localizer). The glide path projection angle is normally adjusted to 3° above the horizontal plane so that it passes through the middle marker at about 60 m (200 ft) and the outer marker at about 426 m (1 400 ft) above the runway elevation. The glide slope is normally usable to the distance of 10 NM. However, at some locations, use of the glide slope has been authorized beyond this range. The glide path provided by the glide slope transmitter is arranged so that it flares from 5 to 8 m (18 to 27 ft) above the runway. Therefore, it should not be expected that the glide path will provide guidance to the touchdown point on the runway.

5.1.1.7 Conventional ILS is subject to siting problems which, at certain aerodromes, can be acute. In addition, at high-density aerodromes further problems with ILS operation may be caused by overflights or by other disturbances. Glide slope and localizer signals are adversely affected by reflecting objects such as hangars, etc. At some locations, snow and tidal reflections also affect the glide path angle to a noticeable degree. In addition, the limited number of channels available for use by ILS may cause interference problems in areas where, due to the proximity of aerodromes, a large number of ILS are required.

5.1.2 Microwave landing system

5.1.2.1 The microwave landing system (MLS) is an improved version of the ILS and has been conceived so as to meet the present and future ICAO functional requirements for landing guidance systems. It is envisaged that MLS will be progressively implemented as of 1990. The transition period where both ILS and MLS will be in operation will extend to the year 2000, when it is expected that ILS will be completely replaced by MLS.

5.1.2.2 The operation of the MLS is based on time reference scanning beam (TRSB) principles. Electronic beams scan the volume of the service area to be covered in a clockwise, then counter-clockwise (to-fro) manner. The scanning generates the angular functions for azimuth, elevation, missed approach azimuth and flare guidance and information. Usable navigation information is provided within an area $+40^\circ$ from runway centre line, between 2° to 10° in elevation and between 20 and 40 NM in range.

5.1.2.3 The degree of sophistication of the MLS at specific locations can range from simple and inexpensive installations to complex systems. The more complex systems enable landing under zero visibility conditions. Unlike the present ILS systems, which basically provide only a single approach path, MLS, while being less subject to siting and interference problems, will cover a wider area, thus providing a number of possible approach paths. In

addition, an integrated DME provides continuous distance information, thus eliminating the need for marker beacons, as with the present ILS.

5.2 OPERATIONAL APPLICATION

5.2.1 Instrument landing system

5.2.1.1 The lowest authorized ILS minima, with all required ground and airborne system components operative, are normally as follows:

- a) Category I — decision height (DH) 200 ft and runway visual range (RVR) 2 600 ft.
- b) Category II — DH 100 ft and RVR 1 200 ft;
- c) Category IIIA — DH (optional with State) and RVR 700 ft.

Note.— *Special authorization and equipment are required for category II and IIIA.*

5.2.1.2 ILS localizer and glide slope course disturbances may occur when surface vehicles or aircraft are operated near the localizer and glide slope antennas. Antenna locations are such that most installations could be subject to signal interference by surface vehicles, aircraft or both, and it is for this reason that ILS critical areas are established on the surface about each localizer and glide slope antenna. Air traffic control (ATC) procedures provide for the control of vehicles or aircraft on the taxiways and runways. One of the aims of these procedures, in relation to ILS critical areas, is to prevent arriving or departing aircraft from causing interference to the ILS when the ILS is being used under weather or visibility conditions requiring such use by other arriving aircraft. Appendix A provides an example of procedures used in the United States for control of aircraft in the ILS critical area.

5.2.1.3 Where ILS systems are installed to serve parallel runways, some States authorize simultaneous ILS approaches if the served parallel runways are at least 1 310 m (4 300 ft) apart. In addition, some States also

permit the use of reduced minimum separation of 2 NM between aircraft established on adjacent localizer courses, if the centre lines of the parallel runways are at least 914 m (3 000 ft) apart.

5.2.1.4 ILS localizer courses can be used to define portions of standard instrument departures (SIDs) and standard instrument arrivals (STARs), thus contributing to the expedition of the traffic flow and a reduction in air-ground communications.

5.2.1.5 When considering the establishment of an ILS, care should be taken to ensure, not only that it serves the preferential traffic flow at that aerodrome, but also to ensure minimum interference with the traffic patterns at neighbouring aerodromes. In addition, environmental (especially noise abatement) considerations are assuming an increasingly significant role in the orientation of an ILS.

5.2.2 Microwave landing system

5.2.2.1 MLS reduces siting problems since it is less critical in respect to ILS and to the adequacy of its site. MLS permits the establishment of flexible, curved, multiple and segmented approach paths in azimuth and elevation and provides improved flare guidance. Such capability increases the traffic handling capacity of ATC and/or helps avoid overflying noise sensitive areas at low altitudes. Such multiple paths also help reduce wake vortex problems, and provide more guidance for missed approaches and departures. Finally, MLS permits the interference-free installation of more facilities in a given area because there are up to 200 channels available in the frequency band in which it operates in comparison with a maximum of 40 channels for ILS.

5.2.2.2 Additional information or application and benefits for MLS and possible approaches to the introduction of the system are contained in ICAO Circular 165 — *Microwave Landing System (MLS) Advisory Circular Issue No. 1.*

— — — — —

Appendix A

General Procedures used in the United States for the Control of Aircraft in ILS Critical Areas

1. When the aerodrome control tower is in operation at controlled aerodromes, and with weather conditions less than ceiling 243 m (800 ft) and/or visibility 2 miles, ATC issues control instructions to aircraft so that they do not interfere with ILS critical areas.
 2. Vehicles and aircraft are not authorized in the glide slope critical area when an arriving aircraft is between the ILS final approach fix and the airport unless the aircraft has reported the airport in sight and is circling or “side stepping” to land on a runway other than the ILS runway.
 3. Except for aircraft that may operate in or over the critical area when landing or leaving a runway, or for departures or missed approaches, vehicles and aircraft are not authorized in or over the localizer critical area when an arriving aircraft is between the ILS final approach fix and the aerodrome. When the ceiling is less than 200 ft and/or the RVR is 2 000 ft or less, no vehicle and/or aircraft operations are authorized in or over the localizer critical area when an arriving aircraft is inside the ILS.
 4. While no specific critical area is established outward from the aerodrome to the final approach fix, an aircraft, holding below 5 000 ft above ground level and inbound toward an aerodrome between the ILS final approach fix and the aerodrome, can cause reception of unwanted localizer signal reflections by aircraft conducting an ILS approach. Accordingly, such holding is not authorized when weather or visibility conditions are less than a ceiling of 800 ft and/or a visibility of 2 miles.
 5. Critical areas are not protected at aerodromes when weather or visibility conditions are above those requiring protective measures as specified above.
 6. Vehicular traffic not subject to control by ATC may cause momentary deviations of the ILS course or glide slope signals.
 7. Critical areas are not protected at aerodromes without an operational aerodrome control tower.
-

Chapter 6

VHF Direction Finder

6.1 FUNCTIONAL REQUIREMENTS

6.1.1 The VHF direction finder (VDF) is a ground based radio aid used by the operator of a ground station and consists of a directional antenna system and a VHF radio receiver. Each time the aircraft transmits on the frequency to which the VDF is tuned, its display indicates the magnetic direction of the aircraft from the station. Recent equipment presents this information as a digital readout. At a radar equipped ATS unit, the VDF indications may be superimposed on the radar display. Where DF equipment is co-located with radar, a strobe of light flashes from the centre of the radar display in the direction of the radar target representing the transmitting aircraft.

6.1.2 VDF stations may operate independently or in groups of two or more stations under the direction of a main VDF station. A VDF network can supply azimuth as well as position information. In this case, the main VDF station integrates, computes and plots the bearings from the individual VDF stations and from this derives the position of the aircraft so plotted. A single VDF station can determine only the relative bearing of the aircraft, unless this bearing is correlated with a reported, intersecting VOR radial. As VDF relies exclusively on air-ground communications, standby or back-up equipment is normally provided for VDF.

6.1.3 VDF stations are usually located on or near aerodromes, a situation that frequently poses significant problems with siting due to obstructions which reflect signals and due to electronic radiation which interferes with the signals. These disturbances will cause perceived signal errors and consequently incorrect bearing and/or position results. If no suitable site is available at the aerodrome, the VDF antenna may be located elsewhere; however, in this case, the bearing information is then given in relation to the antenna site rather than the aerodrome.

6.1.4 Equipment specifications normally require a bearing accuracy of $\pm 4^\circ$ on the azimuth indicator. This deviation may however be greater depending on site, terrain or other factors. A small additional error is introduced when the strobe line indication is superimposed on the surveillance radar display. VDF equipment furnishes bearing information from any aircraft within communications range transmitting on the selected frequency. Any signal within range affects it. Therefore, when two or more aircraft are transmitting simultaneously on the same frequency, bearing indication is determined by the relative strength of the two signals received.

6.1.5 ICAO provisions classify estimated bearing accuracy as follows:

- a) Class A — within $\pm 2^\circ$
- b) Class B — within $\pm 5^\circ$
- c) Class C — within $\pm 10^\circ$
- d) Class D — $>$ Class C

Similarly, the classification of estimated position accuracy is made in accordance with the following:

- a) Class A — within 9 km (5 NM)
- b) Class B — within 37 km (20 NM)
- c) Class C — within 92 km (50 NM)
- d) Class D — $>$ Class C

6.2 OPERATIONAL APPLICATION

VDF is of particular value in locating lost aircraft, in helping to identify aircraft on radar and to guide aircraft to areas of good weather or to aerodromes. At aerodromes equipped with VDF, instrument approaches based on the use of VDF may be offered to aircraft in a distress or urgency condition.

AIR TRAFFIC SERVICES PLANNING MANUAL

PART III

SECTION 2. FACILITIES REQUIRED BY ATS

SECTION 2 FACILITIES REQUIRED BY ATS

Contents

	<i>Page</i>		<i>Page</i>
Chapter 1. General	III-2-1-1	Chapter 3. Requirements for an Area Control Centre	III-2-3-1
1.1 Introduction	III-2-1-1	3.1 Operational requirements	III-2-3-1
1.2 Operational requirements	III-2-1-1	3.2 Structural requirements	III-2-3-2
1.3 Structural requirements	III-2-1-1	3.3 Accommodations and equipment	III-2-3-3
1.4 Accommodations	III-2-1-2		
1.5 Security measures	III-2-1-2		
Chapter 2. Specific Requirements for an Aerodrome Control Tower	III-2-2-1	Appendix A. Check-list — Area control centre operations equipment	III-2-3-5
2.1 Operational requirements	III-2-2-1		
2.2 Structural requirements	III-2-2-2	Chapter 4. Requirements for a Flight Information Centre	III-2-4-1
2.3 Accommodations and equipment	III-2-2-4	4.1 Operational requirements	III-2-4-1
2.4 Other considerations	III-2-2-7	4.2 Structural requirements	III-2-4-1
		4.3 Accommodations and equipment	III-2-4-1
Appendix A. Illustrations of aerodrome control tower designs and layouts	III-2-2-8		
		Appendix A. Check-list — Flight information centre equipment	III-2-4-3
Appendix B. Check-list — Aerodrome control tower and approach control operations equipment	III-2-2-16		

Chapter 1

General

1.1 INTRODUCTION

1.1.1 In view of the fact that air traffic services (ATS) facilities form part of the public service institutions provided by governments, their level of functional suitability, convenience and comfort must correspond to that which governs public service institutions in general. It is, however, also a fact that this level varies considerably from State to State or even within States, depending not only on the specific economic situation, but also on climatological conditions, acquired habits and tradition.

1.1.2 It is therefore nearly impossible to develop standard provisions regarding the layout, installation and furnishing of ATS facilities, especially when covering the non-technical aspects which are more concerned with well-being and/or comfort than with purely operational factors. Nevertheless, under these circumstances and in order to provide some guidance in this respect, discussion of both the essential and the desirable features of ATS facilities follows. It is hoped that States, in consultation with representatives of their ATS personnel will then be able to decide which of the desirable features listed are reasonable and can be provided in addition to those required to meet essential operational requirements.

1.2 OPERATIONAL REQUIREMENTS

At all ATS units, the controller must be provided with a suitable environment and appropriate equipment. The environment should be safe and comfortable and should afford protection from the elements as well as adequate heating, ventilation and, where required by climatological conditions, air-conditioning. Operating space should be ample without being spacious. Controllers should be able to work at their positions without physical discomfort, e.g. chairs should be strong and comfortable while providing proper back support, be adjustable in height, and easily movable. The environment should be sufficiently free from noise so as to be conducive to mental concentration.

Appropriate equipment includes those items which enhance the controller's ability to see and to communicate with aircraft, his colleagues, other ATS units, maintenance personnel, other aviation agencies or bodies, e.g. airlines or military authorities and supporting services such as meteorological (MET), aeronautical information service (AIS), etc. Typical items in this respect are lighting facilities, radio and telephone.

1.3 STRUCTURAL REQUIREMENTS

1.3.1 Special buildings or those parts of other buildings used by ATS should be designed specifically for the particular needs of the ATS unit concerned. The buildings should be sufficiently durable to last for the expected life of the facility they are to house and should be capable of accommodating all personnel, materials and visitors expected to occupy the structure. Additionally, each level should be strong enough to support all equipment and people expected to use that level. The structure should be fireproof.

1.3.2 The initial design should make allowance for flexibility in accommodating occasional relocations of control positions and/or radio or telephone lines. There should also be similar expansion capability in order to accommodate additional or new, operational or administrative equipment.

1.3.3 Sufficient dedicated power (and outlets) should be provided for all existent and anticipated equipment (radar, data automation, etc.), lighting, heating, ventilation, etc. Critical items of equipment, including radio and telephone equipment, should be connected to an uninterruptible power supply, a back-up power generator, and/or two independent power sources.

1.3.4 Where necessary for the exercise of control function, windows must be provided. In all cases, windows should be provided whenever feasible in order to create a normal working environment.

1.3.5 In tall structures, a dual-purpose elevator should be included to be used by personnel and for freight lifting purposes. Space allocated for each function or item of equipment should be ample with reasonable allowance for expansion.

1.3.6 There should be provisions for emergency exits from all personnel areas. In addition, buildings should be provided with lightning protection, emergency lighting, fire alarm and extinguishing systems and security systems.

1.4 ACCOMMODATIONS

Further to the space required for the operations area, buildings serving ATS units should provide for a briefing room, administrative offices, equipment repair space, locker rooms, administrative supplies storage, technical equipment storage, lounge facilities with cooking facilities, toilet facilities, running water (where possible cold and hot), cold drinking water (if the normal running water is not suitable for drinking), outside lighting and a vehicle parking area. At smaller facilities certain space can serve a number of these requirements simultaneously, but at larger facilities this may not be possible. It should, however, be noted that the arrangements for space needed for efficient operation and for the personnel should receive priority consideration in the design of an ATS structure. The requirements in space for certain special equipment are critical, whereas other space requirements, while desirable, are required for convenience only. Specific ATS accommodations are treated in more detail in Chapter 2 to Chapter 4, which follow.

1.5 SECURITY MEASURES

Note.— See also Part IV, Section 2, Chapter 1.

1.5.1 Security measures and procedures will be required to ensure effective control of entry into all areas where air traffic control (ATC) operations are conducted. They must cause a minimum of delay and inconvenience to persons who regularly need access to the secured areas. These requirements apply equally to self-contained ATS buildings as well as to an ATS operations area within a multi-tenant building. In such a building control of access only to the portion occupied by ATS may be required.

1.5.2 Security measures and procedures should take into account the following factors:

- a) self-contained ATS operational buildings are usually surrounded by a security barrier with controlled access points;
- b) where guards are used to control an access point, a communications capability to summon assistance in the event of an emergency will be required in addition to a structure to provide protection for the guard on duty during inclement weather conditions;
- c) at some ATS facilities an additional access control point may be considered necessary. It may be combined with an information or reception desk;
- d) in addition, the appropriate authority may require that specified areas be further protected by restricting access to designated personnel only. Such areas could be:
 - 1) the ATC operations rooms, computer rooms, and associated facilities;
 - 2) telecommunications areas and associated facilities; and
 - 3) service areas housing standby diesel generators, central heating and air-conditioning plants and like facilities;
- e) emergency exits from restricted ATS buildings, areas and rooms will need to be supervised by guards or alarm devices to safeguard against unauthorized use.

1.5.3 Security measures can vary from posting security guards at access points, to the installation of closed-circuit television monitors and/or the security locks operated by special keys or coded cards.

1.5.3.1 While the use of guards is frequently recognized as the most reliable method of access control, the cost of manpower involved in such a system should be weighed against the use of mechanical or electro-mechanical access control devices which may provide an acceptable level of protection.

1.5.3.2 Systems based on the use of special keys, coded cards or a combination of both, are now in widespread use and provide an acceptable level of security. These systems can be encoded in such a manner that the individual is permitted access to all areas or is permitted access only to those areas which the individual is authorized to enter. Some coded card systems also provide for joint use, i.e. an identification card. A weakness in this system, which may be considered a major defect in specific circumstances, and which may therefore have to be taken into account before implementation, is that any person in possession of an appropriately coded card may enter the area to which

access is controlled if that person knows the sequence of use and related procedures in effect.

1.5.3.3 Closed-circuit television monitors and intercom systems provide a sophisticated means of identification

prior to access being granted an individual. Such systems tend to be complex and the installation and maintenance costs may prove to be excessive. In addition, ATS staff on duty may be required to monitor and operate the system to the detriment of their regular duties.

Chapter 2

Specific Requirements for an Aerodrome Control Tower

2.1 OPERATIONAL REQUIREMENTS

2.1.1 An aerodrome control tower has two major operational requirements for an air traffic controller to be able to properly control aircraft operating on and in the vicinity of the aerodrome. Those requirements are:

- a) the tower must permit the controller to survey those portions of the aerodrome and its vicinity over which he exercises control;
- b) the tower must be equipped so as to permit the controller rapid and reliable communications with aircraft with which he is concerned.

2.1.2 Surveillance by the aerodrome controller is normally done by visual means (eyesight) alone, mechanically through the use of binoculars to improve eyesight or electronically, through the use of radar or closed-circuit television. The controller must be able to discriminate between aircraft and between aircraft and vehicles while they are on the same or different runways and/or taxiways. The most significant factors contributing to adequate visual surveillance are the siting of the tower and the height of the control tower cab. The optimum tower site will normally be as close as possible to the centre of the manoeuvring part of the aerodrome, provided that at the intended height, the tower structure itself does not become an obstruction or hazard to flight.

2.1.3 The height of the tower should be such that, at normal eye level (about 1.5 m above the floor of the tower cab) the controller is provided with the visual surveillance previously described. The higher the tower, the more easily this optimum surveillance is attained, but at greater financial cost and with a greater likelihood of penetrating the obstacle limitation surfaces. Reflections in the cab glass and sun or lamp glare through the windows should be kept to a minimum.

2.1.4 Vertical supports for the cab roof should be kept to the smallest feasible diameter so as to minimize their obstruction of the controller's view. The supports should also be as few as possible commensurate with minimizing

reflections. In this respect it should be noted that the less vertical supports, the fewer window panes are required. However, with fewer panes there will also be more reflections. The height of the window sills, which support the windows in the cab, should be as low as practicable since they affect the controller's ability to scan the surface area extending from the base of the tower. For the same reason, tower consoles should be designed so as not to exceed the height of the window sill. The depth of consoles has similar effects on sight limitations. Generally, the higher the window sill and/or the deeper the consoles the larger the surface area extending from the base of the tower which cannot be seen by the controller. Suitable minimum glare or non-glare lighting must be provided to allow the controller to read and write. It must also be arranged so that at night it does not diminish his ability to survey the aerodrome and its vicinity.

2.1.5 The tower controller must be provided with the capability to communicate rapidly, clearly and reliably with aircraft in his area of responsibility. Normally, this is accomplished through air-ground communications. It may occasionally be done by means of a light-gun from the tower using specified signals and prescribed acknowledgements from the aircraft. Since operations in and around a control tower generate a fair amount of noise (e.g. radios, aircraft engines, talking), the provision of sound-deadening features in control towers is very important. Therefore, the acoustic qualities should be taken into account in the selection of structural materials used for control tower construction. Sound-deadening materials should also be used internally, e.g. carpets or similar sound-absorbent material (dust-free and anti-static, if possible) should cover the cab floor and the walls up to the window sills.

2.1.6 The layout of working positions within the tower cab and the consequential arrangement of operating consoles will obviously be determined by the location of the tower in relation to the manoeuvring area, and more especially, the approach direction which is most frequently used at the aerodrome in question. It is also determined by the number of operating positions which are occupied simultaneously in the tower and the respective responsi-

bilities of these positions (control of arriving and departing traffic versus that of ground movements, clearance delivery position, operation of the lighting panel, etc.). As a consequence of this, the layout is most likely to vary from aerodrome to aerodrome and also at an aerodrome as traffic changes. Flexibility and far-sightedness are therefore primary considerations in the initial installation in order to avoid major structural or installation modifications that may result in the future due to changing operational requirements.

2.1.7 It should also be noted that, because of the responsibilities, and the frequent stress involved in the provision of ATC, the provision of other than purely operational facilities contribute to no small degree to the efficiency of the service provided and, as such, deserve careful consideration. They are more fully described in 2.2 and 2.3 below.

2.1.8 In view of the above and what has been said in Part III, Section 2, Chapter 1, 1.1, it should be noted that the illustrations, shown in Appendix A, can only serve as examples of possible arrangements and that final decisions regarding specific control towers must be based on detailed local studies conducted with the active participation of their eventual users.

2.2 STRUCTURAL REQUIREMENTS

2.2.1 Ideally a control tower should be of the required height and should have ample space to ensure an optimum working environment for personnel and equipment (including expansion capabilities), be energy efficient, durable and aesthetically pleasing — all at moderate cost. In the case of control towers located atop the aerodrome terminal building, it has often been found that such a location limits the expansion capability of the facility when air traffic and consequently tower staffing and equipment increase (e.g. radar, automation, etc.). Therefore, at the more important aerodromes or at those where significant future traffic developments are expected, it is better to have a separate control tower structure which is optimally sited, specifically designed to fulfil its operational purpose and whose height is sufficient to best meet ATC needs (see 2.1.3 above). Free-standing control towers have three main components: cab, shaft and base building (see Appendix A, Figure 1). A tower need not have a base building provided its offices, etc., can be integrated into the tower shaft (see Appendix A, Figure 2).

2.2.1.1 The space reserved for the tower cab should be ample but not excessive. As its size is increased, the controller's viewing angle out the opposite side of the tower cab becomes more limited by the height of the window sill (downward) and the roof line (upward). Similarly, physical co-ordination problems between controllers increase with larger space. One State (United States) suggests polygonic cabs of the following dimensions:

Level of activity	Approximate number of personnel simultaneously present in cab	Cab area (square metres)
Low	Not more than 6	21
Intermediate	Between 6 and 12	32
Major	More than 12	50

2.2.1.2 The size of the control cab should be primarily dependent on the number, location and size of control positions and consoles (see Appendix A, Figures 3 and 4). In relation to the primary runways, the cab should be physically oriented so as to obtain the best unobstructed view of the aerodrome manoeuvring area. The orientation should also be such so as to minimize sun glare while controllers monitor the primary areas, especially at sunrise and sunset when the sun is low on the horizon. The window panes should tilt outward to eliminate reflections from the consoles and to provide shading at high sun angles. They should be double-pane, free of distortion, untreated, with the frame banded to the glass for an airtight, waterproof and vapour-proof seal. Interior wall surfaces should be painted in a dark, flat colour to avoid reflections and vertical supports should also be non-reflective and also painted in a dark colour. Minimum clear height from cab floor to ceiling should be 3 m. The ceiling may slope up at its perimeter to enhance upward visibility, especially from the opposite side of the cab. It should be sound-absorbent and painted charcoal gray or flat black to avoid reflections.

2.2.1.3 For washing windows, there should be an automatic window washer or a walkway around the exterior of the tower cab. This walkway should be as narrow as possible and as low as possible (including railing) so as not to impair the controller's close-down view. The walkway may also serve as part of an emergency escape route.

2.2.1.4 If the vertical supports between the window panes are not sufficient to support the roof alone, an additional minimum number of cab columns, with minimum diameter may be used. However, their number should be kept to a minimum commensurate with engineering standards.

These cab columns may be multi-purpose and also serve as roof drain, sanitary vent, conduits for power and antenna cables and the grounding system.

2.2.1.5 Tower cab lighting of variable intensity should generally be recessed in the ceiling and directionally adjustable. Operational lighting required to illuminate a specific working position should be placed and painted so as to minimize glare and reflections. Floor lighting and stair lighting should be recessed and shielded.

2.2.1.6 Carpeting of the tower cab floor should be wear-resistant, sound absorbant, anti-static and flame resistant.

2.2.1.7 Where airport movement radar/airport surface detection equipment (AMR/ASDE) or daylight radar repeater equipment is available, the displays should be swivel mounted, or suspended from a trolley and track in the cab, so that their orientation can be adjusted to remain in the field of vision of the controller concerned under varying conditions.

2.2.1.8 Due to its location, a control tower cab is normally very exposed to changes in atmospheric conditions and a wide variance in temperatures. Therefore, in many cases, a good air circulation is required to retain reasonable working conditions. Where provided, it should be equally distributed around the cab perimeter and operated so as to provide a stable environment. Experience has shown that air distribution from the window sill is better than roof-mounted equipment since the latter arrangement is frequently too noisy for personnel working in the cab as well as more difficult to maintain. A separate air-conditioning and heating/cooling system for the cab will prevent interior fogging or frosting of windows without overheating the cab. It will also prevent or remove the accumulation of ice on the outside of windows. In addition, the system will also serve to heat the cab alone, when it is not yet necessary to heat the rest of the structure, which in certain areas amounts to considerable cost-savings. The thermostat controlling such a system should be located away from exposure to direct sunlight or any other heat source.

2.2.2 The tower shaft has two primary functions; it supports the cab and provides access to the cab by a stairway and/or elevator and as such, it encloses and supports wires, pipes, etc. A secondary function of the tower shaft can be to provide accommodations for personnel and equipment on its different levels.

2.2.3 Where required, a building at the base of the tower shaft may be added as a single or multiple story structure.

Normally, its primary function is to house an approach control unit and/or to provide accommodations for services associated with the provision of air traffic services (ATS). Such an arrangement is preferable to housing these services in the control tower shaft.

2.2.3.1 A free-standing functional shaft (without an associated base building) requires a very small area. It can be readily constructed in prefabricated sections and assembled on location in less time than a conventional building. The disadvantages of free-standing shafts are that they provide for practically no expansion in accommodations and various services are distributed at different levels which generally results in poor communication.

2.2.3.2 A base building combined with a functional shaft provides maximum utilization of space by using the vertical space in the shaft thus reducing space requirements in the base building. However, three separate air-conditioning and heating/cooling systems may be needed for the cab, shaft and base building. Another disadvantage is that the future expansion of those services accommodated in the shaft of the tower are limited.

2.2.3.3 The combination of a base building with a non-functional tower shaft limits the use of the shaft to the point where it houses only a minimal amount of mechanical and electronic equipment but no support personnel. This configuration provides great flexibility in the use of space, offers maximum expansion potential and permits separate construction of the two basic units. Additionally, a single or two-story base building lends itself to a more convenient and efficient circulation of people. The disadvantages are that a larger site is required and the associated design and construction costs are higher.

2.2.4 The material used for the structure of a control tower should be fireproof and all internal material should be fire resistant. In addition, the structure should provide for emergency exit especially from the tower cab and the upper shaft levels. Emergency exit points could be achieved by permanently affixed steel ladders to the outside of the structure or a safety cage on the inside. The structure should also be provided with a smoke detection and alarm system and an ample supply of pre-positioned fire extinguishers which are periodically checked. All stairways should include a hand rail. An elevator should be provided where the cab floor is 15 m or more above the ground. It has also been found that the provision of a central vacuum cleaning system with outlets in each room and blower units remote from normally occupied areas help appreciably in reducing noise.

2.3 ACCOMMODATIONS AND EQUIPMENT

2.3.1 The tower cab should be fitted with consoles to house equipment and provide desk space of the same height as the consoles for writing as well as space to mount monitoring equipment such as aerodrome lighting panels, instrument landing system (ILS) monitor panels, telephone and radio selector panels and brackets to hold microphones and telephone handsets. The console desks should also provide support for flight progress strip holders and should have radio/telephone connexions, including those used for monitoring. There should also be drawers for pens, pencils, paper, etc. Drink holders as well as ashtrays should be located safely away from radio and telephone selector panels and other equipment sensitive to liquid or ash spillings. A supervisor's desk(s) should be provided with necessary telephone and radio terminals and a bookcase should be available to keep appropriate reference material.

2.3.2 Where equipment is enclosed in fixed consoles which are backed to the outer walls of the tower cab, the consoles should open at the front for ease of maintenance. Modular consoles which are easily plugged in and out will similarly help in the maintenance work. If plexiglass tops are provided on consoles and other writing surfaces, regularly used essential charts and other materials may be inserted under the plexiglass. If the consoles and desks are not overlaid with some transparent material, the top surfaces should be made of stain-resistant laminate. Windows may require transparent, glare-proof shades which can be raised or lowered as needed. Where required because of local conditions, towers serving low activity aerodromes with only one or two control positions should have a convenience unit (drinking water, hot-plate or small microwave oven, small refrigerator to permit controllers to remain on the post while eating or drinking). Towers with intermediate or major activity require only the drinking water and possibly a hot-plate in the cab since the refrigerator, etc., generally caters for more persons and therefore must be larger. It can then be located more easily in the tower shaft or in the base building. Stairs leading up to the cab should be located furthest away from the cab operational areas in order to have the least impact on the cab's functional perimeter. There should be a gate at the top of these stairs to prevent accidents.

2.3.3 Where an approach control (APP) unit is located in the tower shaft or base building, provision should be made for a "drop tube" to send current flight progress strips on departures and arrivals to the APP. There should be a secured floor hatch (75 by 90 cm minimum) in the cab floor with an electric mechanical hoist which permits hoisting heavy equipment between the cab and the top elevator

landing. If the highest elevator level is not on the floor level immediately below the tower cab, a hatch should also be provided on any intermediate floor.

2.3.4 For a tower performing a combined aerodrome/approach control function, where APP is equipped with radar and operated from the cab, there may be an additional requirement for special screening of the radar displays to minimize reflections and glare. This special screening may be required despite the use of daylight radar displays (see Appendix A, Figure 5).

2.3.5 In a tower with low activity, the junction level in the tower shaft is primarily reserved to house the equipment work room, control tower mechanical equipment, elevator equipment, toilet and washing facilities. The level below that usually houses the uppermost elevator landing lobby, electronic equipment room and other spaces as required. If the toilet and washroom facilities cannot be located on the level immediately below the tower cab, they must be located on the next lower level in order to keep absences from duty by controllers as short as possible. In radar-equipped towers, equipment rack space for ASDE radar and microwave links may be located on either level. In towers with non-functional shafts, the levels between the base level and the next to last level normally serve only to add height to the tower shaft and to provide access to utility and elevator shafts at the various elevations (see Appendix A, Figure 6). Space in these levels may be used for storage, and other non-operational purposes.

2.3.6 The APP operations room, administrative offices, training and conference rooms, ready or break room, locker room, radar simulator training room, communications equipment room, radar equipment room, automation equipment room, recorder equipment and playback space, telephone equipment room, mechanical and/or electrical maintenance space can all be housed in a base building where provided, or, if space permits, in a functional tower shaft. The immediate economy of accommodating all these functions into a functional tower shaft may, however, be lost if there is no room for future expansion to accommodate new or additional control devices or personnel.

2.3.6.1 The APP operations room size is largely determined by the number of operating positions and radar consoles required or planned for the room. There are two types of radar consoles in use, vertical and horizontal and both types may be used in the same level (see Appendix A, Figure 7). In either case, illumination of the controller's operating position should be such that the presentation of information on the display is not impaired or that its interpretation is rendered difficult. Arrangements should be

made to allow individual controllers to exercise personal preference in this area to the degree that it does not interfere with the requirements of others. Within operational limits, the controller should have control over the intensity of any display which involves the transmission of light. Primary flight data information, i.e. information directly related to the traffic situation, should be displayed in such a way as to avoid significant refocussing of the eyes. For this reason, it is possible that large general displays of secondary information, i.e. information not concerned with the traffic situation, may not be practicable. Space and material for writing notes must be provided. The manipulations required to select specific facilities for use, whether data displays or communications, should be simple. Critical and most frequently used equipment and functions should be located closest to the controller and arranged so that their manipulation follows a logical sequence. A separate desk and adequate lighting, telephone and communications facilities should be provided in the operations room for the watch supervisor.

2.3.6.2 General lighting of operating rooms should be kept at a low ambient level consistent with good working conditions and with reflections reduced as much as possible. However, the floor area should be sufficiently illuminated to prevent accidents, etc. Door openings to lighted adjacent spaces should be screened so that light will not flood the space when doors are opened and interfere with a controller's vision. Operations rooms should be sound-proofed but the floor covering used should still permit chairs to roll easily. Consoles should be of the plug-in plug-out type and/or should be accessible from the rear for maintenance purposes. In some locations where space permits, consoles have been arranged so that they are backed into the radar repair room, thus permitting maintenance while the console remains in place.

2.3.6.3 At some selected locations a room similar to the APP operations room may be required for training controllers in the use of radar in a simulated APP environment. The radar simulator training room should be located in the training area and close to or above the radar equipment room (see Appendix A, Figure 8).

2.3.6.4 A room for training and conferences should be provided at larger facilities. When the size of the room exceeds 22 m² the room should be divisible by a movable type partition with low sound penetration characteristics. Controllable day-light lighting of such rooms is desirable. A chalkboard should be provided for each space. Wherever possible, a roll-up projection screen and an overhead (transparency) projector, as well as a film and slide projector should be included in the room equipment. This space may also be used as a briefing room.

2.3.6.5 The ready or break room provides space for personnel to relax during off-duty periods. Its size will be determined by the number of people likely to use the room simultaneously. Normally, allowance is made for 2.5 m² per occupant but starting with a minimum size of 10 m². In functional shaft facilities the break room should be located near the cab and in aerodrome control towers with a non-functional shaft, in the associated base building near the APP or combined aerodrome control tower/APP facilities. Lighting by controllable day-light is desirable. The layout of the room should separate the eating area from the lounge area and there should be a small counter, storage cabinets, food heating facilities and an appropriately sized refrigerator available in the break room.

2.3.6.6 Recorder equipment automatically records voice communications between controllers and pilots and telephone communications between controllers. The equipment is usually located in the communications room where access to cable ducts is facilitated. Access to recorder equipment and tapes should be restricted to only authorized personnel because of the valuable nature of recording tape in the investigation of incidents. When not installed in the chief controller's office a separate playback equipment room may be provided to permit personnel to listen to recordings for training purposes. When the playback equipment is portable it may be set up for use in other existing rooms. There should, however, be a separate tape storage room in a secure area to avoid the possibility of tapes being tampered with. The tape storage room should preferably be located away from areas which are frequented by many persons.

2.3.6.7 Whenever there is a requirement for operational equipment, there is a complementary requirement for technical equipment. Space provided for technical equipment must be ample and as close as possible to its operational counterpart(s). Therefore suitable provisions should be made for the housing of communications, radar and telephone equipment plus the required cable ducts and other utilities. Space for electronics equipment, in respect of required cable lengths is particularly critical, as are temperature, in some cases, and the cleanliness of the room.

2.3.6.8 Administrative personnel will require appropriately sized offices, furnished and decorated in accordance with their respective positions. Some functions will require a completely enclosed office while open-plan partitions (about 2 m high) will suffice for others. Clerical staff other than the unit secretary should be assigned common space. Staff establishments vary with facilities, therefore, office space may be required for some or all of the following (or counterpart) titles: Chief Controller; Deputy; Operations

Officer; Plans and Procedures Officer; Training and Evaluation Officer; Data Systems Officer; Personnel Officer; Chief Controller's secretary; and secretarial pool.

2.3.6.9 The locker room provides a space for personnel to secure their personal belongings while they are on duty, or a place to store work equipment while they are off duty. The locker room size depends on the number of personnel requiring lockers. Lockers are placed in rows, with an aisle of sufficient width (1.2 m) to allow personnel to pass. Lockers are normally provided with separate coat compartments and small upper compartments and should be provided with locks to all compartments. The locker room should be adjacent to the rest or ready room (see Appendix A, Figure 9).

2.3.6.10 Lavatories must be provided adjacent to areas occupied by personnel and, as a general rule, one toilet may be provided for occupancies of 15 persons or less. Where there is an APP operations room, the lavatories shall be located nearby; however, a lavatory should be located on the closest possible level below the cab in all towers. If a rest area is not provided elsewhere within the facility, there should be one in the women's lavatory. The arrangement and installation of the lavatories should, at least, correspond to the level normally provided in public service installations, i.e. accessories, mirrors, grab bars, soap and towel dispensers, waste receptacles, coat hooks, etc., as required.

2.3.6.11 The peak demand for parking at the facility will determine the required employee parking lot size. However, in some cases allowances need to be made for official cars and visitors. Normally, peak demand for parking will occur during shift changes. A study and evaluation of the largest concentration of personnel at the facility during this shift change (employee, visitor and official vehicle parking) will determine the capacity required.

2.3.7 Where aerodrome ground radar surveillance equipment is available, it will normally be mounted on the roof of the cab and the display(s) mounted in the cab and readily accessible to view by the ground control and the local control positions. The installation of the display should be made so that it poses the minimum obstruction to the controllers' direct view of the aerodrome traffic. Where an APP is collocated, and a repeater radar display is mounted in the cab, it should be readily accessible to view by the local controller and without creating any obstruction to view.

2.3.8 The aerodrome lighting control panel should be incorporated in a cab console or in a separate desk. The ILS monitor panel/alarm should also be mounted in the cab console but can be in a less utilized area. Radio and telephone selector panels should be installed at the control positions and should include emergency and other special use telephone equipment. Depending on their number and personal preference, radio speakers may be mounted in the consoles or a special overhead rack suspended from the ceiling. Other cab equipment includes wind direction and speed indicators, altimeter readout indicator, light-gun(s) and clock(s) and, where required, remote runway temperature readout. Where the tower personnel have been assigned the additional responsibility for making partial weather observations, cloud height and temperature indicators should be included. A link to the local meteorological station and to aeronautical information service (AIS) needs to be included and, in some cases, a connexion to the computer of the associated area control centre (ACC) so that flight plan information can be exchanged.

2.3.9 Towers with intermediate and major activity should be supplied by one commercial power source and one uninterruptible power supply; or one commercial power source and one standby power generator capable of supplying power to all critical equipment within 15 seconds of failure of normal power supply; or two independent sources of commercial power. Where the primary commercial power source is of poor quality, a power stabilizing system should be considered for installation to prevent damaging voltage surges.

2.3.10 Provision should be made for emergency lighting as follows:

- a) for an aerodrome control tower without power generator, the emergency lighting should be battery supplied and provide lighting of exits, corridors and stairs, interior spaces housing critical electrical and mechanical equipment and critical areas having electronic equipment;
- b) for an aerodrome control tower/APP with a power generator, the emergency lighting arrangements should cover:
 - 1) battery lights in the power generator and electrical rooms;
 - 2) reduced lighting connected to the emergency power supply for the cab, the APP operations room (spots and floor lights only), the radar and communication equipment rooms, the electrical/mechanical room, the break room and the lavatory;
 - 3) exit corridors and vestibules should be sufficiently lighted by the emergency system to provide illumination for emergency exiting.

2.3.11 There should also be an internal telephone system at towers with intermediate and major activity. All the operation rooms, the more important work rooms and offices and some strategic locations in the general areas (entry hall, etc.) should be provided with clocks. Where necessary, adequate security systems should be provided (see Part III, Section 2, Chapter 1, 1.5).

2.3.12 If the location of the aerodrome served by an ATS unit, in relation to nearest housing, is such that commuter distances to work are excessive and/or if housing at reasonable cost cannot be found by personnel within a reasonable distance from the aerodrome, it may be advisable to consider the development of a residential housing project in co-operation with the appropriate local public authorities.

2.4 OTHER CONSIDERATIONS

Where APP is provided for one aerodrome only, the APP will normally be accommodated within a control tower structure unless it is performed by one or more sectors within an ACC. In some rare cases where approach control for a number of closely located aerodromes is provided from one APP and where neither of the two preceding arrangements is satisfactory, a stand-alone terminal control centre (TMC) may need to be provided to perform the APP function. In this case it is most likely that it will resemble a miniaturized version of an ACC and the provisions for such a facility apply, albeit on a reduced size (see Part III, Section 2, Chapter 3 — Requirements for area control centre).

— — — — —

Appendix A

Illustrations of Aerodrome Control Tower Designs and Layouts



Figure 1.— Aerodrome control tower with base building and non-functional shaft serving an intermediate activity aerodrome — outside view

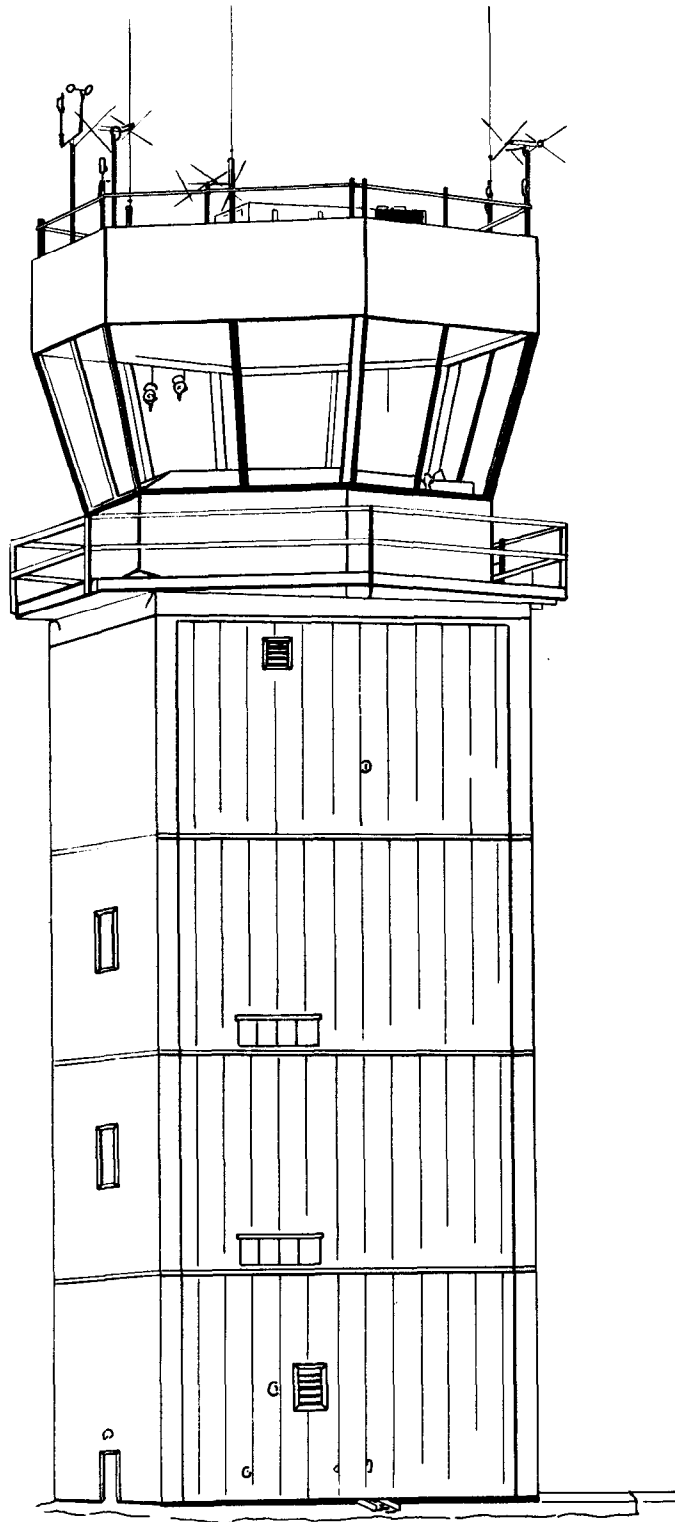
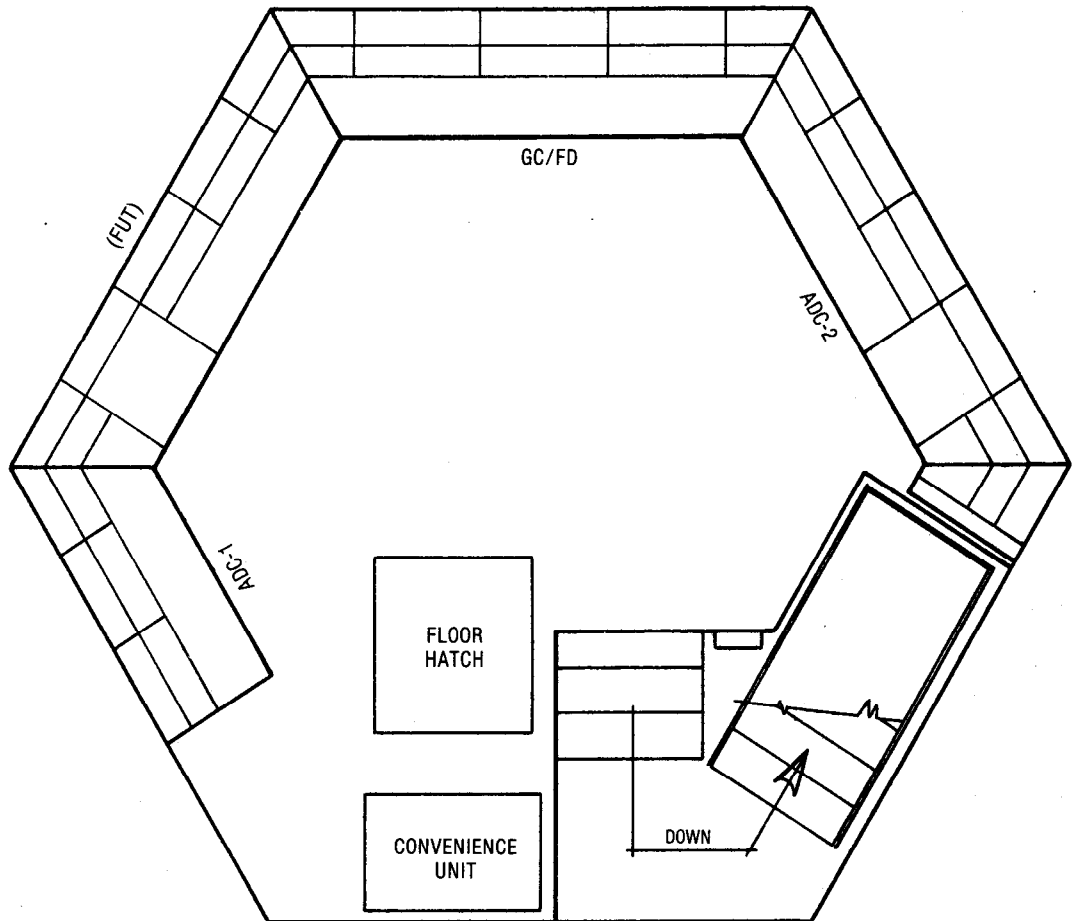

Figure 2.— Free-standing aerodrome control tower with a functional shaft serving a low activity aerodrome — outside view



CAB FLOOR PLAN

Key to symbols

- ADC = Aerodrome control
- GC = Ground control
- FD = Flight data
- (FUT) = Future

Scale

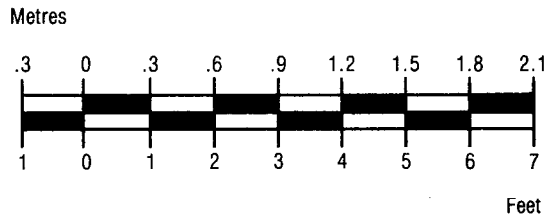
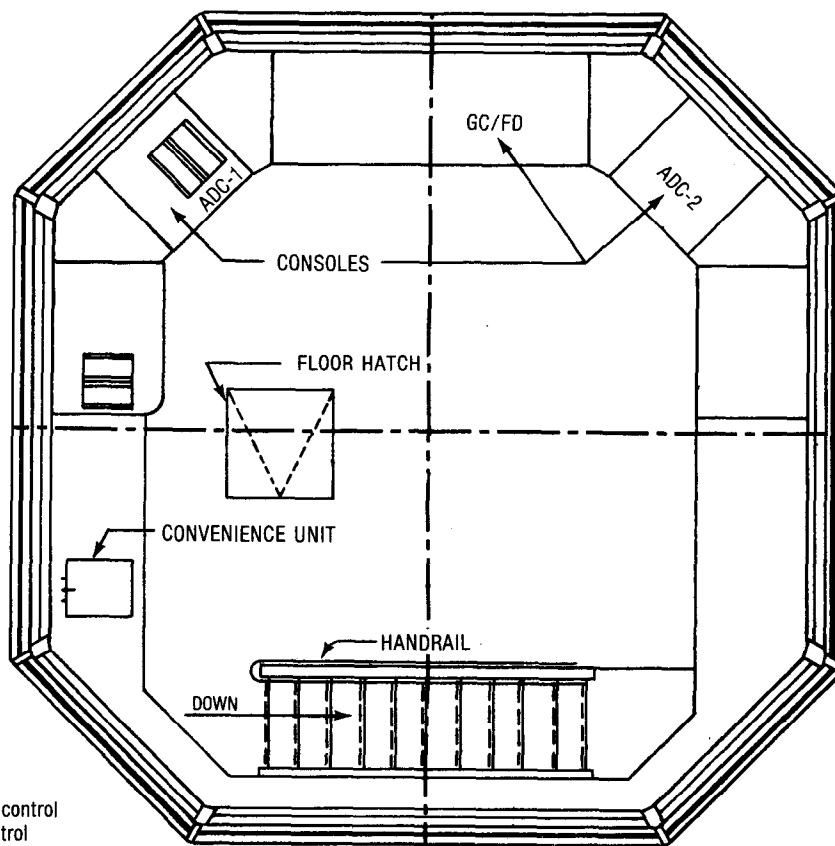

Figure 3.— Interior layout of a low activity aerodrome control tower cab



Key to symbols

- ADC = Aerodrome control
- GC = Ground control
- FD = Flight data

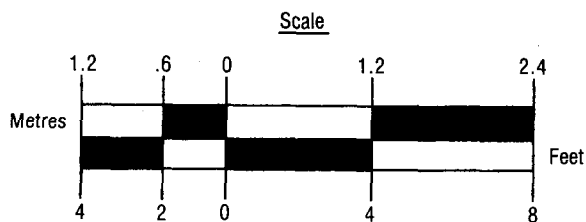
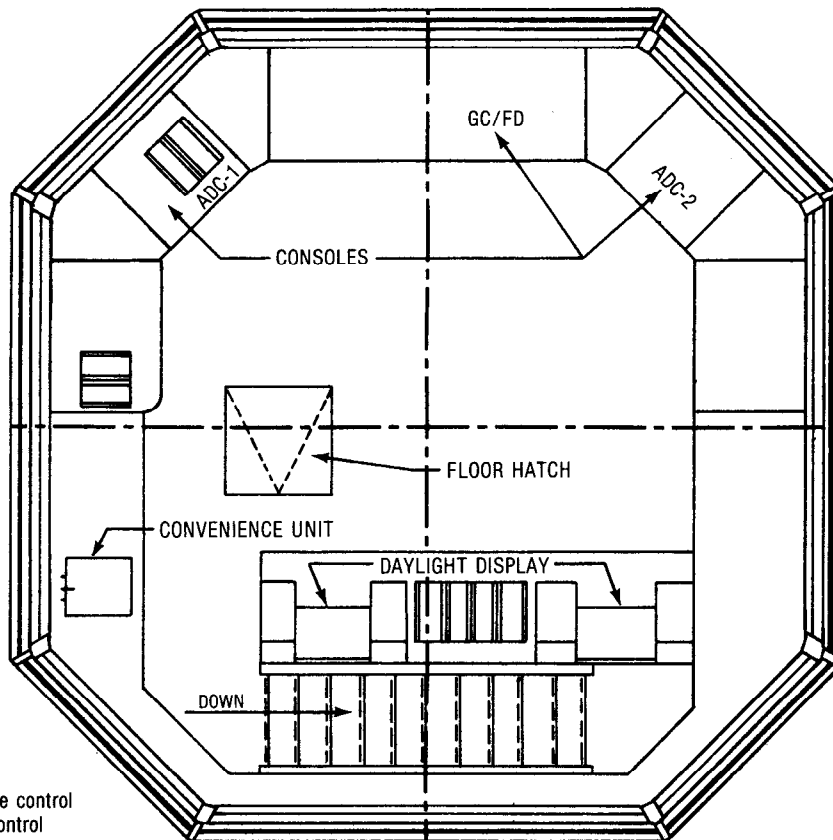

Figure 4.— Interior layout of an intermediate activity aerodrome control tower cab



Key to symbols

- ADC = Aerodrome control
- GC = Ground control
- FD = Flight data

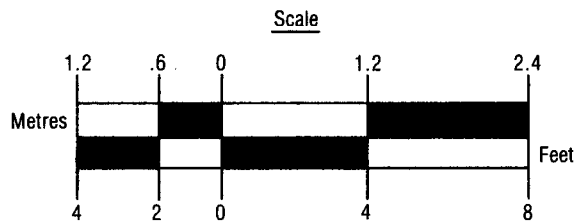

Figure 5.— Interior layout of an intermediate activity aerodrome control tower cab with radar-equipped approach control in the tower cab

SPACE RELATIONSHIPS

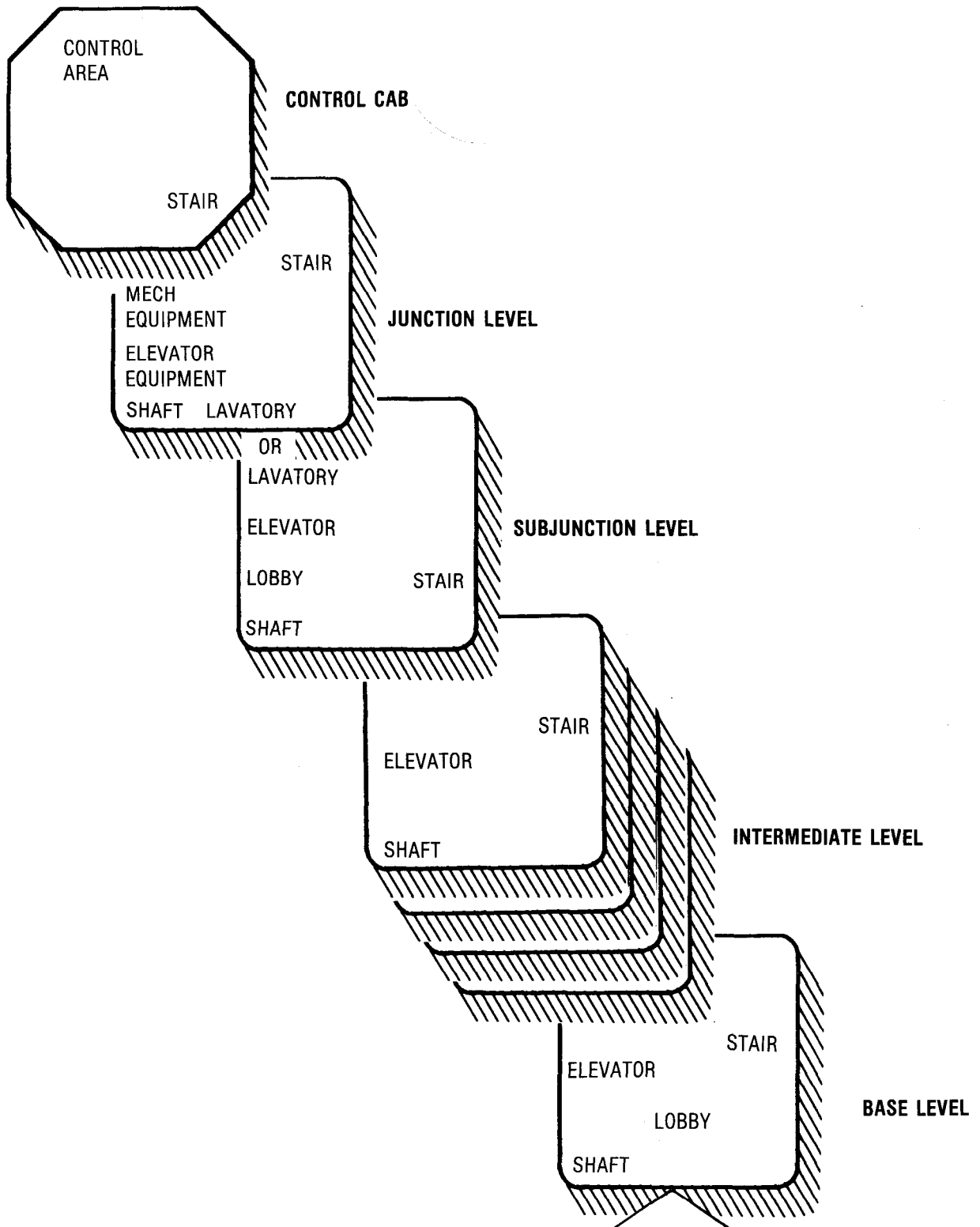
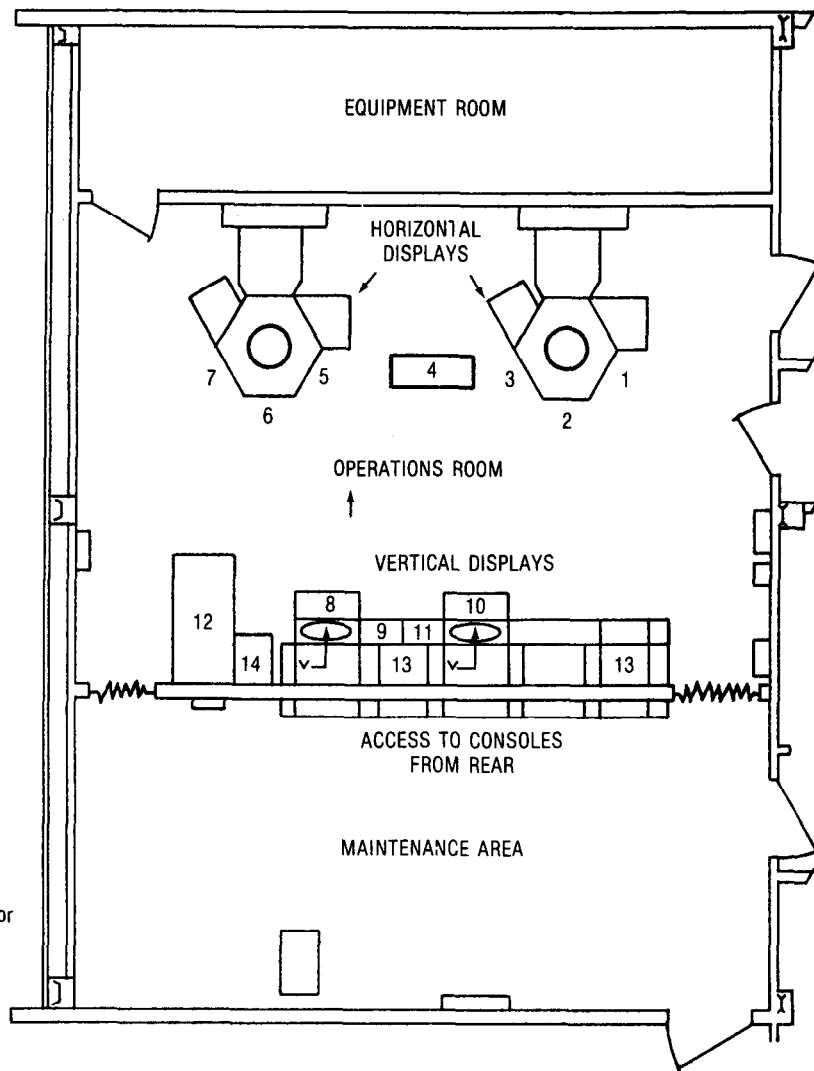
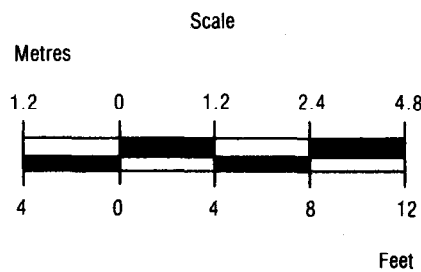

Figure 6.— Diagram of the level arrangement in the non-functional shaft of an aerodrome control tower



Key to numbered positions

- 1 to 3 = Control positions
- 5 to 10 = Control positions
- 4 and 11 = Co-ordinator positions
- 12 = Assistant chief/Watch supervisor
- 13 = Strip printers
- 14 = Local weather & NOTAM circuit



FLOOR PLAN

Figure 7.— Layout for approach control operations room using horizontal and vertical displays

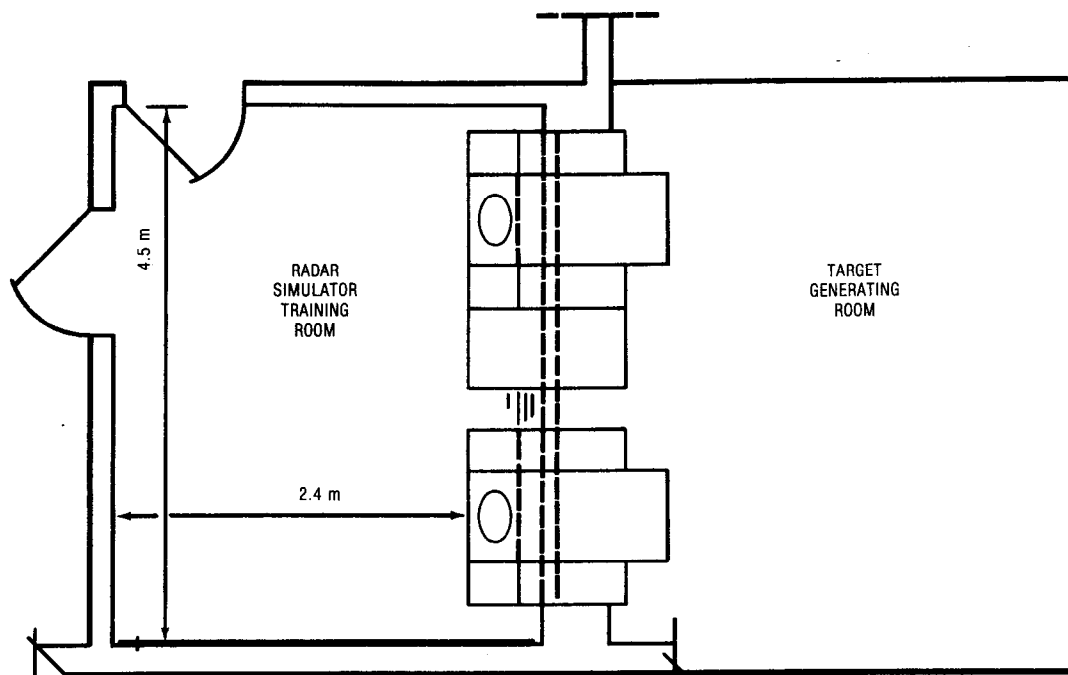

FLOOR PLAN

Figure 8.— Layout for radar simulator training room

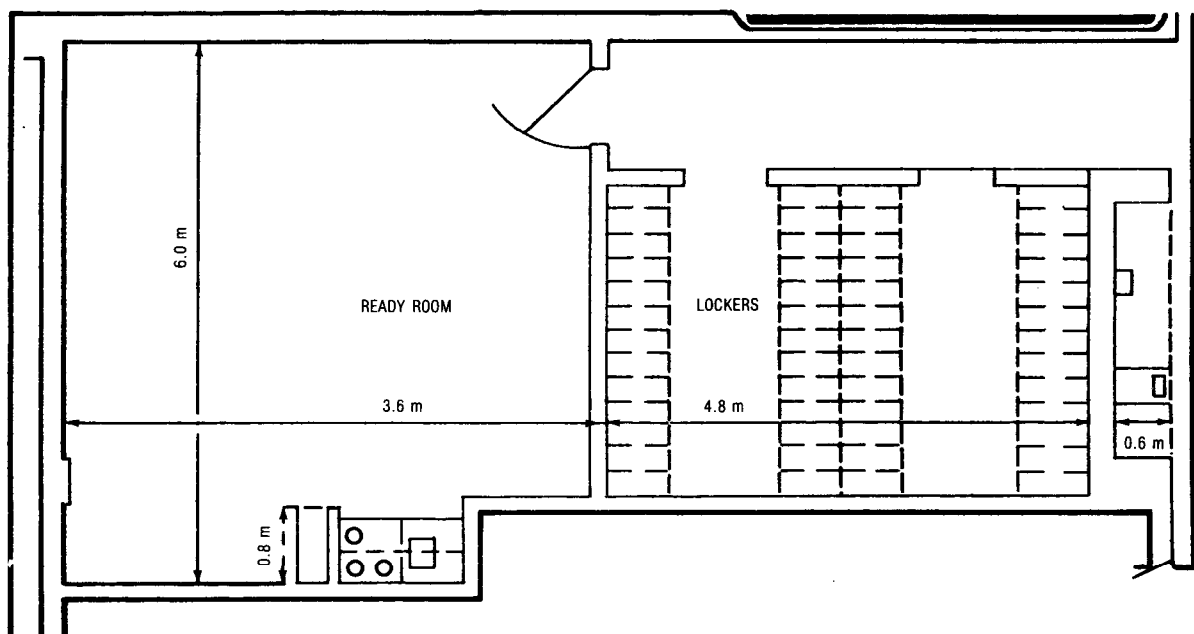

FLOOR PLAN

Figure 9.— Possible layout for a ready and locker room

Appendix B

CHECK-LIST

AERODROME CONTROL TOWER AND APPROACH CONTROL OPERATIONS EQUIPMENT

Item	Tower only	APP in Tower cab	Separate APP
1. Headset	X	X	X
2. Microphone	X	X	X
3. Transceiver	X	X	X
4. Speakers	X	X	X
5. Radio selector panel	X	X	X
6. Telephone selector panel/handsets	X	X	X
7. Intercom	X	X	X
8. Auto-switch headset/speaker	X	X	X
9. Recorder (radio and telephone)	X	X	X
10. Power	X	X	X
11. Back-up power	X*	X	X
12. Signal lamp and reel	X	X	
13. Wind speed and direction display	X	X	X
14. Barometric altimeter	X	X	
15. Altimeter setting indicator	X	X	X
16. Clock	X	X	X
17. Aerodrome lighting panel	X	X	
18. Navaid(s) monitor panel	X	X	X
19. Lighting, including emergency lights	X	X	X
20. Daylight radar/display consoles	X*	X	
21. Radar displays, controls, consoles			X
22. Secondary radar controls		X	X
23. Radar simulator			X
24. Flight data panel	X	X	X
25. Automation equipment		X	X
26. Clipboards/displays (NOTAM etc.)	X	X	X
27. ATIS recorder		X	X
28. Fire alarm and extinguishers	X	X	X
29. Desks/consoles/shelves	X	X	X
30. Chairs	X	X	X
31. Shades	X	X	
32. Air conditioning, heating/cooling	X	X	X
33. Convenience group (hot-plate/water, etc.)	X		
34. Lunch facility		X	X
35. Water fountain		X	X
36. Bookcases	X	X	X
37. Binoculars	X	X	
38. Sound-absorbing coverings (floor/wall)	X	X	X

* Where necessary due to particular circumstances.

Chapter 3

Requirements for an Area Control Centre

3.1 OPERATIONAL REQUIREMENTS

3.1.1 Area control centres (ACCs), broadly speaking, are divided into three levels of development. At the first and most basic level, the ACC relies on flight progress strips for its method of control. For each flight, a flight progress strip is prepared for each designated reporting point. The estimates on each strip are updated by the controllers as the flight passes through the airspace of the ACC. The control methods used at this level are generally referred to as procedural control.

3.1.2 At the second and more advanced level, the ACC relies on radar as its primary means for controlling traffic. When the radar displays, used by the ACC, are horizontal, plastic markers are moved along the surface of the display to aid the controller in maintaining the identity of individual radar targets representing aircraft under its control. For both vertical displays and horizontal displays, flight progress strips continue to serve as back-up for the information displayed by radar. At some radar-equipped ACCs, strips are prepared (including the calculation of estimates) by a strip printer and automatically distributed to the proper control sectors.

3.1.3 In the third and most advanced level of operation of an ACC, radar information is digitized and strips are computed, printed and distributed automatically. However, what is more significant, the identity and other pertinent data relating to each radar target are shown on the display together with the associated target.

3.1.4 At all three levels the controller is provided with the combined capability of being able to communicate with aircraft, to monitor their flight progress, and to determine potential conflicts between flights. However, since much of the work done by ACCs involves co-ordination with adjacent ACCs or other air traffic control (ATC) units, it is equally important, at all levels, that ACCs are provided with adequate means to permit controllers to co-ordinate their activities, both within an ACC and also with adjacent ACCs and/or other associated ATC units (aerodrome control towers, approach control units (APP)) in the area

of responsibility of the ACC concerned. The primary means for this purpose are direct telephone links and, where automation is used, automatic exchanges of data generated by the computer within an ACC for sector to sector co-ordination or automatic exchanges of data between the computers of adjacent ACCs. The more sophisticated levels of development provide ACCs with an increased traffic handling capacity and higher controller productivity.

3.1.4.1 Because of the widely varying conditions under which ACCs are required to operate, there is no single, optimum solution to the problem of layout of an ACC. Each one has its advantages and disadvantages and will vary with the method of control used (procedural, radar, etc.), the number of sectors required and the available space. Layouts now in use include straight line, controllers back to back, rows of parallel consoles/displays, all oriented in the same direction, horseshoe configurations of operating positions and island configurations where assistants' consoles are arranged beside controllers' consoles, or arrangements where assistants operate from the back of the controllers' consoles (teepee-type arrangement). However, the layout selected for a specific ACC should mainly be determined by the need to facilitate intra-centre co-ordination (i.e. between sectors) to the maximum extent possible and permit a logical flow of information between operating positions as flights progress.

3.1.4.2 At individual operating positions within the ACC, the radio, intercom and telephone control panels should be located within easy reach of the controller and should be simple to operate with quick response times. Connexions for headsets and telephones should be conveniently located and should be duplicated to permit monitoring of controllers and/or trainees as necessary. Additionally, a separate desk equipped with telephone and communications channels should be provided in a convenient location in the ACC for the watch supervisor. To keep the noise level down, every controller position as well as each co-ordinator position and the watch supervisor position should be equipped with an interphone system to permit communication with and between operating

positions in the ACC. Complete sound-absorbing treatment of the floor, walls and ceiling of the operations room is necessary.

3.1.4.3 The brightness control of radar displays is critical. The controller should have the ability of individually and conveniently controlling the brightness of his display. Any glare and spillover of light from adjacent positions should be shielded and reflections from other sources masked. Polarized screening of radar displays is effective in eliminating reflections, not only from the overhead map board of the particular operating position, but also from those of the opposite row of sectors where controllers work back-to-back. General lighting of the operations room above the level of the display should be kept at the lowest possible level consistent with operational needs. Illumination below the console shelf level should be that required for safety.

3.2 STRUCTURAL REQUIREMENTS

3.2.1 For an ACC, a one or two storey stand-alone building of sufficient size to accommodate all present sectors and other equipment and positions which must be installed in the operations room, plus expansion space, access to reliable utilities, parking area and within reasonable commuting distance to suitable housing of employees would be ideal. The operations room should have ample space to permit the addition of further sectors in accordance with realistic forecast requirements, sufficient space between the rows of sectors for free movement, and sufficient space at the rear of each console to permit ease of maintenance. The room should be high enough to facilitate sound-proofing and, in view of the general interest in such facilities, should be provided with adequate arrangements to permit non-technical visitors to observe the operation without distracting controllers. If other than the ground floor level(s) of the building have to house heavy items of equipment, a freight elevator will also be required.

3.2.2 A briefing room, limited to team size, should be located close to the operations room. It can be used for briefing sessions and for current pre-shift, individual, briefing. Where required, individual delivery boxes (pigeon-holes) may also be installed in the briefing room. A ready room or break room for employee relaxation, to provide relief from operational stress, fatigue and tension, should be located near the control room for convenience during brief breaks. Where possible, it should be provided with an intercom system permitting the recall of required personnel. A bulletin board area and a literature rack for

reading materials are desirable. Planning should be based on a minimum of 2 m² per person of the expected simultaneous occupancy.

3.2.3 Training and conference rooms in excess of 25 m² should have arrangements for being divided by a movable type partition with low sound transmission characteristics. Controllable natural window light is desirable.

3.2.4 At selected ACCs where radar control is the primary means of control, it may be advisable to provide a radar simulator room or space to allow training of personnel for higher qualifications and/or for the conduct of proficiency checks. If provided, it should include two to four consoles, including programmable displays, to display control problems which may, but need not, include the presentation of "live" targets as they appear on displays used in the operations room. The room should be adjacent to the computer equipment room and the training room. If space is available which can be partitioned off, the area where the radar simulator training is conducted may even be located in the control room.

3.2.5 Where provided, the playback room should be used to listen to recorded communications, either for the purpose of supporting investigations into incidents and/or to improve controller performance. The area should be provided with the required equipment including a lockable tape storage unit. The room should be acoustically treated to eliminate background noise and should be located in a secure area of the facility.

3.2.6 The communications equipment room and the radar equipment room should be located as close as possible to the operations room. The telephone equipment room should be located adjacent to the communications radar equipment room or operations room. The same applies to the automation equipment room if the ACC is using automation. These equipment rooms need not, however, be located on the same level as the operations room, but would be equally well sited immediately above or below it.

3.2.7 The locker room should provide space to secure personal belongings while controllers are on duty and to store work equipment (headsets, etc.), when off duty and should be located near the operations room. The size of the room depends on the number of lockers required. All lockers should be lockable.

3.2.8 Administrative space includes offices or space for the chief controller, and, as required for the deputy chief, administrative assistant, chief's secretary, stenographic pool, operations officer, procedures and plans officer,

personnel officer, data systems officer, military liaison officer, proficiency training officer, cartographer as well as appropriate offices and space for the maintenance personnel. Adequate lobby and reception space should be provided adjacent to the major administrative area.

3.2.9 Provisions should be made for on-site food preparation and storage if the facility is remote from local markets and suppliers. When a cafeteria is provided, this may only operate during those periods of the day when a large number of people are working. To supplement the cafeteria service during the hours when the cafeteria is closed, food and drink dispensers may be provided and located in the rest room or break area.

3.2.10 Lavatories should be provided adjacent to areas of personnel occupancy. The number of toilets should be in accord with local or State code requirements for number of occupants. One or more should be located near the operations room. One or more should be designated for female use only, when appropriate.

3.3 ACCOMMODATIONS AND EQUIPMENT

3.3.1 There should be access to current weather information at each control position, preferably through individual or shared displays between adjacent positions. A link to the appropriate meteorological service is necessary in the operations room.

3.3.2 In addition, in all ACCs, an input-output link will be needed to handle control messages, approval requests (mass military movements and others), etc., received and transmitted via these links. In those ACCs where flight progress strips are computer prepared and delivered, provision must be made at the appropriate number of sectors for output printers.

3.3.3 The area reserved for the watch supervisor and, where required, the supervisory maintenance man, on duty should include desk space, telephone and intercom selector panels, and, where appropriate, a selectable radar display. Storage space for reference documentation will also be required.

3.3.4 If smoking is permitted in the operations room, consoles or desks should be fitted with ashtrays. If beverages are permitted, there should be built-in holders located safely away from all selector panels and other areas where inadvertent spillage could cause damage. There should also be small built-in drawers below the writing surface for

pencils, paper, etc. Every sector should have a 24-hour clock; additional clocks should be placed in all other major work areas. These clocks should be controlled by a master clock which should be checked for correct time at least once a day.

3.3.5 Control room chairs should be comfortable, with armrests and supportive backs, and be adjustable in height and back inclination. They should roll easily on the floor covering.

3.3.6 Water should be available in all lavatories and rest rooms. Where required by climatological conditions, chilled drinking water should be readily available in the operations room and other personnel areas.

3.3.7 The training and conference rooms should be equipped with chalkboards, and, if possible, a roll-up projection screen, an overhead projector and film and slide projectors. There should be a suitable number of desks-chairs as well as an instructor desk or suitable lectern.

3.3.8 Emergency lighting in the operations room should be provided by spotlights and floor lights only. Other areas requiring emergency lighting are exit corridors and vestibules, the power generator room, the electrical and other equipment rooms, the rest room and the toilets.

3.3.9 The fire alarm system should consist of heat sensing and ionization smoke detectors, manual alarm stations, fire extinguishers, and control panels. The smoke detectors should be located in areas where a fire is most likely to break out. Manual alarm stations should be provided at exits. The fire control panel should be located at the main entry with a remote annunciator at the operations room. The control panel should activate an alarm and be capable of shutting down air-conditioning equipment. The control panel should also be connected to the local fire department. There should be an ample supply of pre-positioned fire extinguishers.

3.3.10 Each ACC should be provided with a security system adequate to the likely threats to which the facility may be exposed (see also Part III, Section 2, Chapter 1).

3.3.11 A central vacuum cleaning system should be installed for ease of maintenance. However because of noise, its blower units should be remote from areas which are normally occupied during duty hours.

3.3.12 A heating, ventilation and air-conditioning system should be provided and installed so that disturbance by the noise of its operation is kept as low as possible in the

control room, offices, conference and training rooms, and in the lounge and rest room.

3.3.13 Each ACC should be supplied by a commercial power source and an uninterruptible power supply, or by one commercial power source and one standby power generator capable of supplying power to all critical equipment within 15 seconds of normal power supply failure, or by two separate commercial power sources.

Where the primary power source is of poor quality, a power stabilizing system should be installed to control damaging voltage surges.

3.3.14 The demand peak in parking facilities at the facility should normally determine the required size of the parking lot; the peak will occur during shift changes. Additional arrangements to accommodate visitor and official vehicles should also be considered.

Appendix A

CHECK-LIST

AREA CONTROL CENTRE OPERATIONS EQUIPMENT

1. Headsets
 2. Microphones
 3. Transceivers
 4. Speakers
 5. Radiocommunications selector panels
 6. Telephone selector panels and handsets
 7. Intercom
 8. Clocks
 9. Recorders (radio and telephone)
 10. Daylight radar displays and consoles including radar controls
 11. Secondary surveillance radar controls
 12. Radar simulator
 13. Automation equipment including input/output devices
 14. Flight progress boards
 15. Teletype for weather and for aircraft movement messages
 16. Weather displays including appropriate altimeter settings
 17. Clipboards and wall projection devices
 18. Bulletin boards for posting pertinent information
 19. Desk
 20. Chair
 21. Lighting — including emergency lighting
 22. Fire alarm and extinguishers
 23. Water fountain
 24. Lunch facility
 25. Heating — air conditioning/cooling
 26. Power
 27. Back-up power
-

Chapter 4

Requirements for a Flight Information Centre

4.1 OPERATIONAL REQUIREMENTS

A flight information centre (FIC) is a unit established to provide flight information service (FIS) and alerting service as specified in Annex 11 (see Part I, Section 2, Chapter 2). The basic operational requirements for FICs are the capability to obtain meteorological and other aeronautical information, and the capability to communicate with aircraft, other air traffic services (ATS) units, and associated aviation offices, e.g. search and rescue units, operators by radio, telephone, teletype.

4.2 STRUCTURAL REQUIREMENTS

4.2.1 Flight information and alerting services are in many instances provided by area control centres (ACCs), approach control (APPs) or other air traffic control (ATC) units. In those cases it is sufficient to allocate an area within the operations room or the aerodrome control tower cab for the FIS equipment and the establishment of a separate structure is not required. Combinations of other aeronautical services with FIS is also possible (see Part I, Section 2, Chapter 2).

4.2.2 Where a stand-alone FIC has been established, the building should be capable of properly housing the operating personnel and the equipment listed in 4.3 below. The building can be relatively small and simple. There need not be emphasis on expansion capability since a step up would probably result in provision for an ATC unit requiring a significantly different kind and size of building.

4.2.3 Nonetheless, the stand-alone FIC should be durable, have proper heating/cooling and ventilation facilities, sufficient electric outlets, windows, good lighting, and sufficient parking area. There should be space for storage of supplies and records. The building should be fire resistant, with an adequate number of entryways. Radio antennas can be located on the roof. Space should

be set aside for the unit chief's office and for other administrative and maintenance needs as required.

4.3 ACCOMMODATIONS AND EQUIPMENT

4.3.1 Whether the FIC is a stand-alone facility or its function is included within another ATC unit, its operational equipment will be identical.

4.3.2 There should be an appropriate writing area and counter space and a display area to enable FIC personnel to keep track of aircraft for which the FIC is responsible. This can best be achieved by use of flight progress boards and equipment. There should be wall space or other adequate space to display maps, charts and similar material for easy reference. Air-ground communications with microphones and speakers or headsets are needed and a selector panel is desirable. Telephones, including selector panel, connecting with adjacent ATS units may be needed to connect the FIC with appropriate aerodrome control towers, APPs, ACCs, the associated rescue co-ordination centre or equivalent office, meteorological offices, appropriate operators' offices, NOTAM office and military units. Radio and telephone positions should have dual connexions for training and monitoring purposes. Recording equipment for both air-ground and telephone communications is desirable.

4.3.3 If possible, the FIC should have a receive unit for meteorological maps. Unless provision is adequately covered by other arrangements, the FIC should be able to make use of direction-finding equipment to plot bearings to help locate lost aircraft. There should be sufficient teletype equipment to send/receive weather information, NOTAM and flight data messages. Clipboards to maintain current NOTAM are desirable. Charts showing the approach procedures at controlled aerodromes, aerodrome layouts and similar material should be available and displayed at the operations desk or counter-top. Where possible, the material may be stored in a carousel slide

projector equipped with a selection device for projection onto a convenient light wall or projection screen in case of need. Clocks and bookcases for storage of reference material are needed. Suitable chairs are necessary.

4.3.4 A stand-alone FIC should also have lavatory facilities, running water and chilled drinking water where

required by climatological conditions as well as fire extinguishers and a limited amount of emergency lighting. Where necessary, a security system, adequate to the likely threat to such a facility, should be provided.

4.3.5 Appendix A provides a check-list of equipment normally required in an FIC.

Appendix A

CHECK-LIST

FLIGHT INFORMATION CENTRE EQUIPMENT

1. Writing area/counter space
2. Plotting table
3. Navigation plotting equipment
4. Large-scale area map
5. Headsets
6. Microphones
7. Speakers
8. Radiocommunications, selector panels
9. Telephones and selector panels
10. Teletype
11. Access to direction-finding equipment*
12. Flight progress console and equipment*
13. Clocks
14. Typewriter and table
15. Lighting
16. Chairs
17. Storage for reference documents
18. Lavatory
19. Running water
20. Fire extinguisher
21. Emergency lighting
22. Drinking fountain
23. Heating-air conditioning/cooling
24. Power
25. Back-up power

* Where particular circumstances warrant.

AIR TRAFFIC SERVICES PLANNING MANUAL

PART IV

**ATS ORGANIZATION, ADMINISTRATION AND
FACILITY MANAGEMENT**

AIR TRAFFIC SERVICES PLANNING MANUAL

PART IV

SECTION 1. ORGANIZATION AND ADMINISTRATION

SECTION 1

ORGANIZATION AND ADMINISTRATION

Contents

	<i>Page</i>		<i>Page</i>
Chapter 1. Organization of Air Traffic Services	IV-1-1-1	Chapter 3. Training and Proficiency Requirements	IV-1-3-1
1.1 Introduction.....	IV-1-1-1	3.1 Introduction.....	IV-1-3-1
1.2 Functions and activities.....	IV-1-1-1	3.2 Formal training.....	IV-1-3-1
1.3 Management positions and duties.....	IV-1-1-2	3.3 On-the-job training.....	IV-1-3-2
Appendix A. Typical civil aviation organizational chart.....	IV-1-1-4	3.4 Proficiency training.....	IV-1-3-3
Appendix B. Typical ATS organizational chart.....	IV-1-1-5	3.5 Management training.....	IV-1-3-4
		3.6 Familiarization flights.....	IV-1-3-5
		Appendix A. Guidelines used by one State for proficiency training assessment and evaluation.....	IV-1-3-6
Chapter 2. Personnel Requirements, Recruitment and Progression	IV-1-2-1	Chapter 4. ATS Licences and Ratings	IV-1-4-1
2.1 Determination of personnel requirements.....	IV-1-2-1	4.1 Introduction.....	IV-1-4-1
2.2 Recruitment.....	IV-1-2-2	4.2 Requirement for air traffic control licences.....	IV-1-4-1
2.3 Career progression.....	IV-1-2-2	4.3 Requirement for air traffic control ratings.....	IV-1-4-1
2.4 Supplementary considerations.....	IV-1-2-3	4.4 Ratings for senior and supervisory personnel.....	IV-1-4-2
2.4.1 Additional terms of employment.....	IV-1-2-3	Appendix A. Provisions regarding air traffic controller licences.....	IV-1-4-3
2.4.2 ATC's role in the civil service.....	IV-1-2-3	Appendix B. Provisions regarding air traffic control ratings.....	IV-1-4-5
2.4.3 International aspects of service conditions.....	IV-1-2-3	Attachment 1. Subjects for basic knowledge questions.....	IV-1-4-6
Appendix A. Criteria and methods used by Sweden for psychological and physiological evaluation of controllers.....	IV-1-2-5		

Chapter 1

Organization of Air Traffic Services

1.1 INTRODUCTION

1.1.1 The objectives of air traffic services (ATS) and the functions of the service are set out in Annex 11; however, neither the objectives nor the functions of ATS can be satisfactorily accomplished unless there is an organization to administer the service, and methods established through which the objectives can be achieved. As the safety and security of civil aviation remains the ultimate aim, the management of the ATS must be developed with this in mind.

1.1.2 In one form or another, States generally divide the over-all administration of civil aviation into regulatory, engineering planning and servicing divisions. It is the latter which is of most significance in the day-to-day conduct of civil and military flying and it is the individual air traffic controller who exercises the important function of preventing collisions and advising aircraft of known hazards. The procedures a controller uses, the equipment he operates, the building he occupies, the training he receives are all intended to free him so that he can concentrate solely on this task.

1.1.3 It is generally accepted that in the organization of the ATS there will be a section of the central or Headquarters administration responsible for the over-all policy, planning, personnel and budgetary management of ATS. This section should have a high enough ranking in the government hierarchy to assure that an equitable share of the total resources available are assigned to ATS (i.e. money and people) and that the importance of the role of ATS in the determination of the over-all priorities and policies of the administration is recognized.

1.1.4 A regional organization may be a part of the ATS structure, although operating semi-independently in the provision of day-to-day service. Such a delegation of functional responsibility to the field by Headquarters allows individual ATS units to be grouped under a common regional management. These units may comprise area control centres (ACCs), approach control offices (APPs) and aerodrome control towers, and their task is to provide

ATS at the operational level and within a geographical region.

1.1.5 While ICAO Doc 7604, *Information on National Civil Aviation Departments*, provides details on the organization of civil aviation administrations in individual Contracting States, an example of a typical civil aviation organization is shown in Appendix A.

1.2 FUNCTIONS AND ACTIVITIES

1.2.1 A civil aviation administration is charged with the responsibility for promoting and supervising the development of civil aviation in the State concerned while, at the same time, fostering safety, achieving the efficient use of navigable airspace, and developing and operating a satisfactory air navigation system.

1.2.2 The director of civil aviation issues and enforces rules, regulations and minimum Standards relating to the operation of aircraft, the licensing and rating of personnel including the supervision and enforcement of medical standards, the operations specifications for commercial air operations, the surveillance of air operations, the operation of the air navigation system and the provision of ATS.

1.2.3 The safe and efficient utilization of the airspace is the primary objective of ATS. To this extent, air traffic rules are developed and the use of the airspace is organized. ATS also develops the procedures necessary for a safe and efficient system of ATC and specifies the facilities, accommodation and equipment required to accomplish this. This includes all types of communications equipment, including radar and other visual and electronic aids to navigation.

1.2.4 Furthermore, ATS develops the training and physical standards for the employment of air traffic controllers, arranges training programmes and provides simulators and training devices unique to ATS. The licensing and rating of ATS personnel by examination and the maintenance of satisfactory performance level is the

task assigned to controllers trained in evaluation and teaching techniques. Headquarters determines the number of qualified personnel required to operate a unit. It negotiates terms and conditions of employment and concerns itself with the working environment.

1.2.5 Headquarters staff of ATS should include air traffic controllers with advanced experience in the performance of ATC and knowledge of actual field requirements.

1.2.6 Finally ATS participates in other essential civil aviation activities such as the establishment of requirements for air navigation aids, and the development of aerodromes, particularly in respect to the design and layout of the movement area and the alignment of runways in relation to adjacent circuit traffic patterns. As computer technology is used more and more by ATS, selected controllers should be trained in the development of software programmes in order to ensure that equipment meets the controllers requirements.

1.3 MANAGEMENT POSITIONS AND DUTIES

1.3.1 The descriptions of several key positions and their duties in the ATS field are provided below. These descriptions are by no means exhaustive, nor may all the positions listed here be required in all administrations.

a) *Director, Air Traffic Services* is responsible to the Director of Civil Aviation for:

- 1) establishing ATS policies, standards and procedures;
- 2) ensuring the efficient operation of ATC units in accordance with approved policies, standards and procedures;
- 3) maintaining discipline, efficiency and proper deportment of ATS personnel;
- 4) investigating complaints against and operational irregularities within the ATS;
- 5) collaborating in the investigation of accidents and breaches of air regulations and air navigation orders;
- 6) providing training programmes;
- 7) recommending changes in ATS;
- 8) ensuring close liaison with users of the ATS;
- 9) recommending required changes in personnel, equipment, communications, space and operating positions;
- 10) providing representation regarding the selection and promotion of personnel;

- 11) making recommendations regarding the evaluation, development and research of new systems and equipment;
- 12) preparing the annual ATS budget programme;
- 13) implementing approved programmes within the financial limits;
- 14) ensuring that adequate security measures are maintained at all ATC units.

b) *Chief, ATS Operations* is responsible to the Director, Air Traffic Services for:

- 1) supervising and inspecting ATC units;
- 2) ensuring that all units operate in accordance with approved policies, standards and procedures;
- 3) assisting in investigating complaints, incidents, accidents, and breaches of air regulations and air navigation orders;
- 4) resolving operational problems between regions and making recommendations concerning inter-unit problems, where required;
- 5) ensuring appropriate distribution of responsibility and workload to regions or units;
- 6) arranging for flight surveillance of ATS procedures, controller performance and the adequacy of air-ground communications.

c) *Chief, ATS Personnel* is responsible to the Director, Air Traffic Services for:

- 1) implementing all aspects of the ATC training programme;
- 2) co-ordinating the selection of personnel for training;
- 3) co-ordinating medical examination programmes and developing required procedures;
- 4) recommending action regarding employees who fail to acquire or to maintain the necessary proficiency;
- 5) evaluating progress and potential of trainees;
- 6) developing and revising training programmes to satisfy national requirements;
- 7) reviewing training aids and material required for training programmes;
- 8) conducting such liaison and familiarization with all regions or ATC units as is necessary to be thoroughly conversant with current requirements for training throughout the ATS branch;
- 9) co-ordinating with other branches as required;
- 10) where adopted as policy, arranging familiarization flights and inter-unit liaison visits.

d) *Chief, ATS Planning* is responsible to the Director, Air Traffic Services for:

- 1) organizing the ATS airspace and planning of associated procedures;
- 2) reviewing existing procedures;

- 3) planning the development and maintenance of airspace requirements;
 - 4) recommending system improvements;
 - 5) assisting in the preparation of agreements between ATC units and military ATC units and between national ATS and foreign governments;
 - 6) developing and maintaining effective relationships with other branches and divisions, other departments and agencies, civil aviation industry organizations and associations and users of the system;
 - 7) supervising the financial resources of the division.
- e) *Chief, ATS Technical Evaluation* is responsible to the Director, Air Traffic Services for:
- 1) programming the provision of electronic communications and other ATC equipment;
 - 2) evaluating new systems;
 - 3) developing installation plans to ensure optimum use of equipment;
 - 4) participating in the development of training programmes covering equipment utilization;
 - 5) co-ordinating with the communications branch and other agencies regarding communications and equipment;
 - 6) developing regional ATC space requirements, plans and layouts;
 - 7) ensuring that adequate equipment and supplies are available to units;
 - 8) checking the quality of performance and reliability of equipment in use in ATC units.
- 1.3.2 While acting under the delegated authority from the Director of the ATS branch, chiefs of regions or ATS units should have relative freedom of action regarding the management of their staff, and also in the disposition and control of funds allotted to their activity, provided such funds are expended in compliance with applicable rules.
-

Appendix A

Typical Civil Aviation Organizational Chart

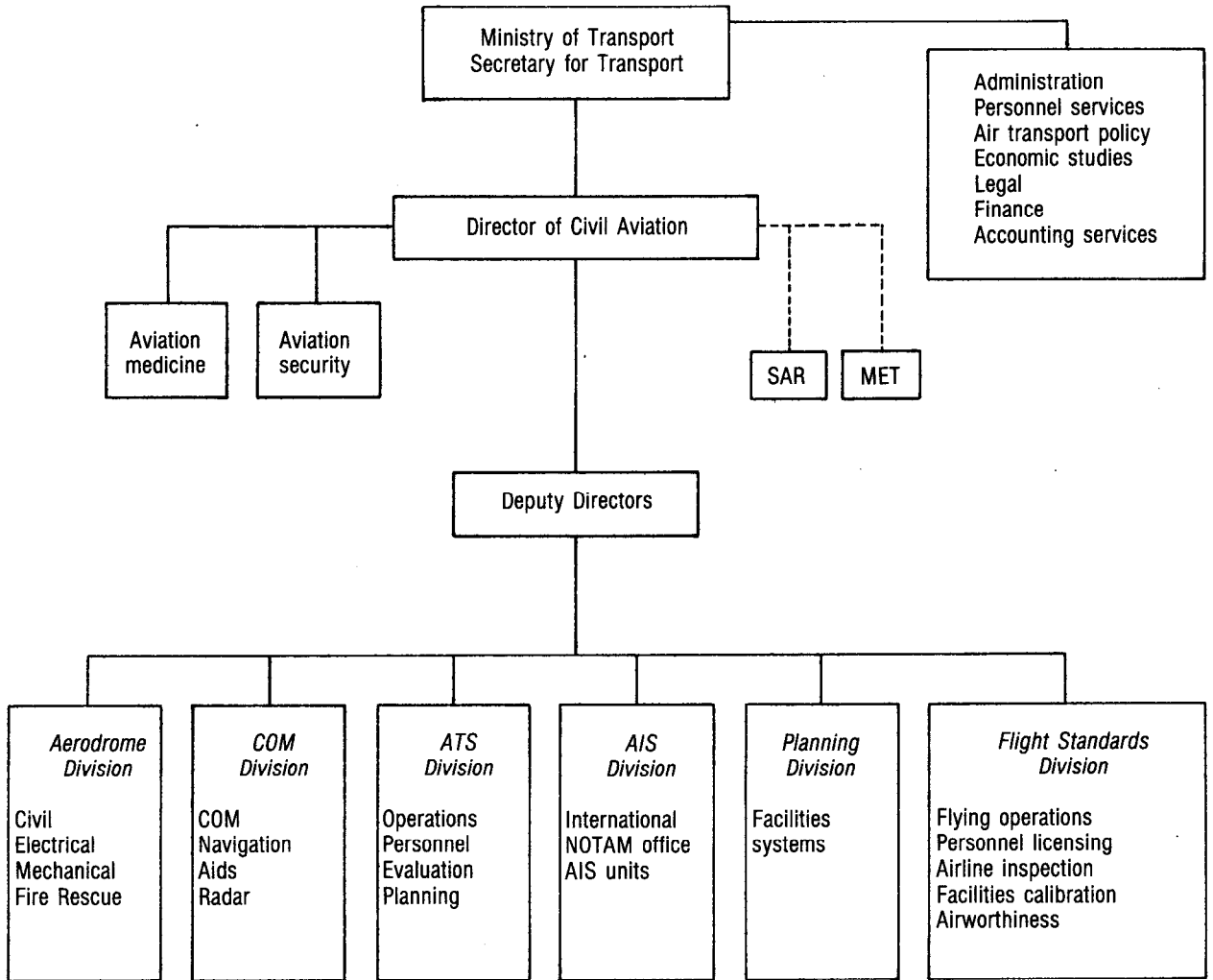

----- Co-operative arrangements with the service concerned

Appendix B

Typical ATS Organizational Chart

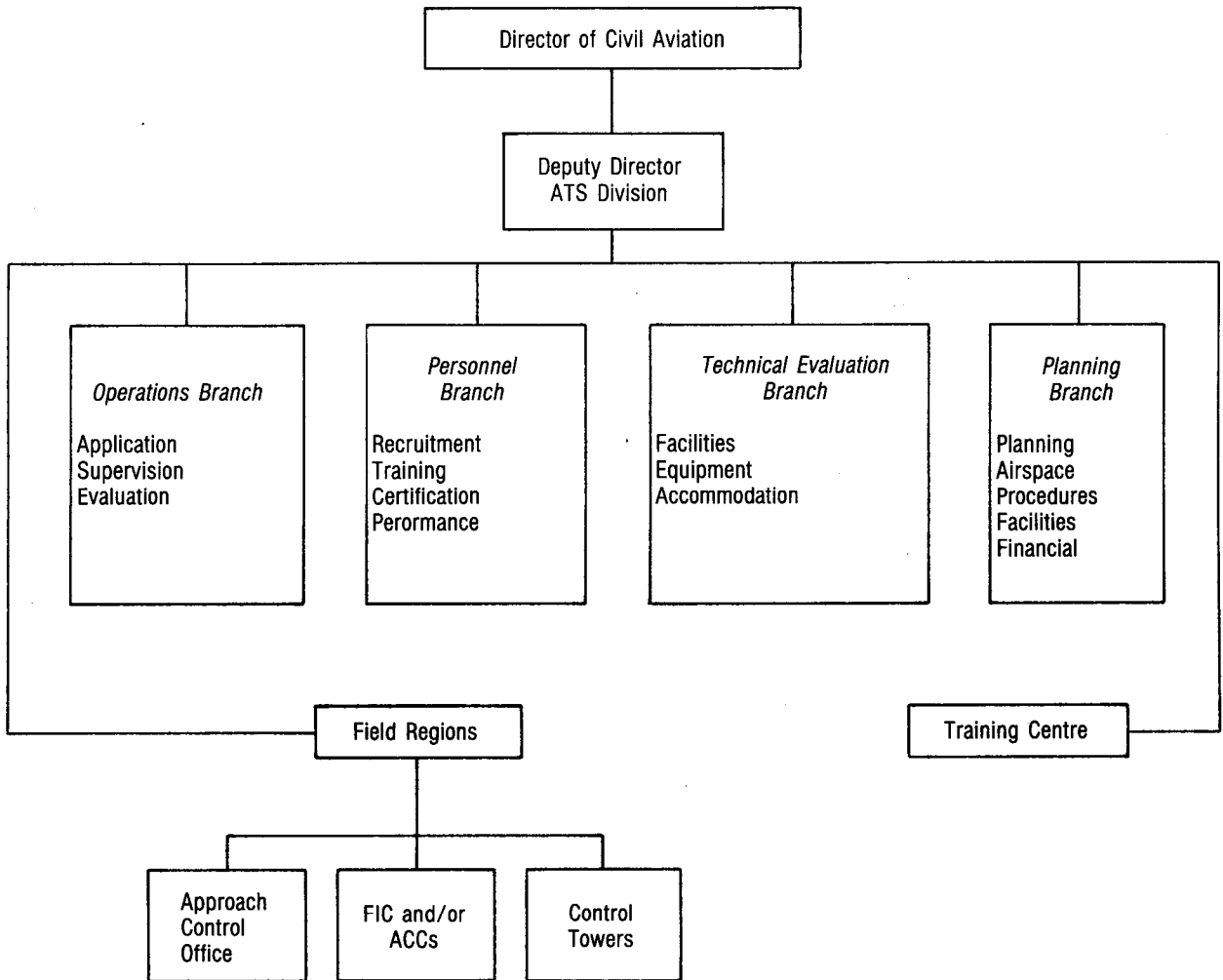

Chapter 2

Personnel Requirements, Recruitment and Progression

2.1 DETERMINATION OF PERSONNEL REQUIREMENTS

2.1.1 The upsurge in air traffic movements in most States in recent years has resulted in a rapid increase in the number of controllers needed. Manpower planning is essential to ensure that there is always sufficient trained staff available to meet the demands of the service. Such planning should forecast future manpower requirements for at least five years. In planning for manpower requirements acquisition of reliable data plays as important a role as does determining the methods of handling the traffic. Personnel requirements are usually determined by a study based on a comprehensive assessment of the duties to be performed.

2.1.2 A properly balanced workload scheme not only justifies the number of persons employed but it also protects against the overloading of any particular work position. In the latter capacity, it acts as a safeguard because employees who are frequently overloaded cannot be expected to be as efficient as those working under normal conditions.

2.1.3 A significant feature of air traffic services (ATS) work is the necessity for speedy and prompt action in all fields of operation. Such action may be required to be performed at high pressure during peak hours while action may slacken off during other times of the day or night. Such variations in the activity patterns have shown the need for the definition of a "peak man-hour" as the amount of work which can be performed by one person in an average peak hour: ATS workload schemes should be based on these peak man-hours. The purpose of the workload system should provide a basis, but not necessarily a rigid yardstick, for the assessment of the number of staff required at each unit, to identify periods of significant activities at units and to ensure that adequate safety margins are maintained. Should it be found that overloading becomes a frequent occurrence, a review should be conducted to determine which modifications of working arrangements or facilities are needed to provide relief, or whether additional staff is required. In some cases, such a

review may also indicate that, by appropriate modifications of the working arrangements, savings in manpower are possible. Seasonal variations in traffic may have significant effects upon the workload, but these should normally be anticipated and provided for by manpower scheduling or other management action.

2.1.4 To convert the abstract requirement for the provision of specific services into the number of days of operation from which the number of controllers required to provide that service can be calculated, the following method may be used:

- a) determine the number of days of facility operation based on a general calculation of expected controller utilization or availability. This calculation should be based on a statistical mean and will give only an average figure;
- b) determine the average number of days during which the average controller is away from the facility. Days away from the facility should include days off duty, leave, sick leave, absence for advanced training and any other cause;
- c) the information on the number of days of facility operation and average number of days a controller is away from the facility should then be inserted into a formula in order to obtain the number of controllers required to provide the service in question in the course of a year. A typical example of such a formula is:

$$\text{Personnel needed} = \frac{\text{Number of days a position is in operation per year}}{\text{Number of days of operation of the facility per year}} \times \frac{\text{Number of functional hours* per year}}{\text{Average number of hours worked per year by a controller**}}$$

* "Functional hours" means the hours when the position is occupied plus time for hand over.

** The "average number of hours" worked per year by a controller is obtained by subtracting from the days of the year the number of days the average controller is away from the facility. This figure is then multiplied by the average number of working hours per day of a controller.

2.1.5 As duty at some positions is more fatiguing than at others, supervisors should, at their discretion, rotate staff during their shifts between heavily loaded and more lightly loaded positions.

2.1.6 When making a workload study of any operating position, sector or unit, the study should be related to an hour-by-hour loading and normally not be confined to only one day's operations. A more representative result will be obtained if the study covers a week or longer period. The arithmetic average of the workload values obtained for individual hours should then be plotted. However, any exceptionally busy day or other shorter period may be plotted separately if it appears desirable to make this occurrence more outstanding.

2.1.7 Workload studies should be made in support of all proposals to change the staffing whenever such a proposal is based on workloading. Otherwise, studies should be made when it is believed that overloading is occurring with some regularity or that the functions of two or more positions may be combined without compromising safety or creating overloading of the so combined new position.

2.1.8 An essential feature of any method used in conducting workload studies is that the assessment team should include a controller who is experienced in controlling traffic in the area under review but not personally involved in the control function.

2.1.9 Some States have devoted a considerable amount of work to the development of methods of estimating ATS capacity. Such work is still continuing; however, details of such work may be obtained from any ICAO Regional Office.

2.2 RECRUITMENT

2.2.1 The requirements for issuing ATS licences and ratings are prescribed in Annex 1, *Personnel Licensing*. The standards a candidate must meet to satisfy the medical and experience requirements determine to a large extent the conditions which govern the recruitment and selection process. Recruitment is normally made from two sources of manpower; these are:

a) students in the age group from 17 to approximately 25 years, recently qualified to university entrance standards in subjects which should include the spoken language and the common aviation language used in the area, mathematics or science or physics, written expression and geography;

b) other persons who have qualified for and exercised the privileges of a commercial pilot or flight navigator or an equivalent military qualification, or allied professional or specialist qualifications. In these cases it is usual to establish an upper acceptable age limit at about 35 years.

2.2.1.1 Selection methods normally follow established interviewing techniques requiring both written and oral examination with the latter emphasizing motivation. Psychological aptitude and manipulative tests are used by many States and it is usual to have candidates medically examined in accordance with the requirements in Annex 1 as part of the selection process. A method used by one Civil Aviation Administration (Sweden) is shown in Appendix A.

2.2.2 Because of the special nature of the ATS, persons selected for service in ATS require considerable training before they can qualify for a licence. Such training is a costly process, making it necessary to have arrangements whereby a candidate, who is unable to reach a satisfactory standard of performance within set time limits, may have his employment terminated. Most ATS personnel are civil servants and their initial employment contract provides for a period of probation during which they can be dismissed or reassigned. In general, such action will be taken only for misconduct or negligence. However, in the case of ATC trainees the unsuitability for retention results more likely from temperament, slow reaction time or inability to anticipate, visualize and analyse complex situations. Special arrangements therefore need to be made in their contracts to cover this eventuality.

2.2.2.1 During the probationary period, in addition to classroom instruction, candidates should be tested on the job by assigning them to units where they should perform supplementary duties assisting the controller, but under continuous supervision. In this way, the candidate will gain confidence and the employer can assess his potential and possibly take corrective action before a loss of confidence occurs. This on-the-job training is the most significant element of the training process and the ability to handle people firmly but compassionately should therefore be a major criterion in the selection of supervisory personnel.

2.3 CAREER PROGRESSION

2.3.1 Service with the ATS is a career in itself, but in common with most other disciplines, as employees become more skilled, some of them are likely to aspire to increased

responsibilities and the associated social advances. As the task of controlling air traffic does not develop management skills, personnel should therefore be given the opportunity to attend varying levels of administrative instructional courses to provide a career structure through to top management positions. Individual assessments of progress, together with the on-the-job assessments, will permit an employee the opportunity to demonstrate fitness for promotion, and also allow management to have a broader group from which to select possible candidates. Some States require such candidates to pass promotion examinations. However, regardless of the method chosen, it appears unlikely that a good controller will automatically become a good supervisor unless he is given adequate training and opportunity.

2.3.2 Once a candidate has qualified for an ATS licence, he will be required to obtain a rating, qualifying him to work at a specific ATS unit. It is usual for a basic grade controller to return to the training school to be taught advanced ATS techniques so that he can compete for positions of higher responsibility and also to ensure that a pool of qualified staff is always available to meet normal staff attrition.

2.3.3 Experience has shown that because of the special work involved in ATS and the comparatively high qualifications and skills required in the exercise of this profession, States would be well advised to arrange that their ATS personnel have terms and conditions of employment and promotion prospects which are related solely to ATS work and are as independent as possible of the normal civil service career structure.

2.4 SUPPLEMENTARY CONSIDERATIONS

2.4.1 Additional terms of employment

2.4.1.1 Considerations additional to those applied to the normal civil service probation requirements must be taken into account when determining the suitability of an ATS trainee, i.e. operational factors as distinct from behavioural factors. Other considerations concern the recognition of air traffic control (ATC) qualifications and responsibilities in relation to administrative or professional tasks.

2.4.1.2 A number of States have found it expedient to create a specialist occupational group for ATS with salary and gradings separated from the clerical, administrative or professional scales. Thus responsibility comparisons with

civil aviation employees outside the civil service can be made for ATS personnel without disturbing inter-service wage and other relativities.

2.4.1.3 It is likely that the terms and condition of employment, particularly in respect to the amount of annual leave, the number of sequential shifts between days off, the duration of shifts including maximum working hours per shift, the conditions covering sick leave and varying definitions of health in relation to availability for work will also be additional to standard civil service conditions. These additional conditions of employment should be written into any industrial agreement for the ATC occupational class and the information on special controller agreements made readily available to all ATS personnel.

2.4.2 ATC's role in the civil service

2.4.2.1 It is generally recognized that ATS does not easily fit into the civil service because of its involvement in public safety and the essentiality of ATS in respect to public air transport. As a result, ATS personnel have found that their industrial bargaining position is different from that of most other civil services. To avoid constant confrontation, ATS management and employee committees should be formed so that problems can be aired as they arise. Access by employee representatives to senior management should not only be accepted but should be actively encouraged when safety is claimed to be the basis of unrest.

2.4.2.2 It is usual for government organizations to have a standard code for personnel conditions which include the working area per person, furniture, floor coverings and other similar items. Such a code does not usually satisfy the ATS working requirements. Administrative action is therefore necessary to exempt ATS planners from adhering to standard codes where the operational requirement can justify specialized treatment. Areas of obvious conflict arise in the design of public offices vis-à-vis ATC operational rooms such as the need for the latter to have a higher ceiling height, special lighting, special acoustic treatment such as noise absorbent floors and ceilings, and the need for more efficient ventilation, heating and cooling than usual (see Part III, Section 2, Chapters 2 and 3). To avoid such conflict, consideration should be given to consulting working environment specialists in those cases where the environment has an influence on the operating capacity of personnel concerned (e.g. use of radar and/or video displays).

2.4.2.3 Because it is usually very difficult for ATS personnel to transfer to, or gain promotion in other disciplines of the civil service, controllers tend to group together

in specialized associations and seek affiliation on an international scale. Experience indicates that the civil service and management should not object to such affiliations to ensure industrial harmony. On the whole, ATS personnel are singularly dedicated to their task and a State may have much to gain from the knowledge which flows from international communication. From time to time administrations may therefore be confronted with requests to support participation by elected ATS representatives at safety symposia dealing with ATS matters. In general terms, the administration may be well advised to give favourable consideration and limited support to justified requests, on an ad hoc basis, in order to preserve good labour relations and offer educational opportunities to its ATS personnel.

2.4.2.4 On occasion, ATS personnel will require access to or receive information bearing on national security and intelligence and it is therefore necessary to make ATS subject to higher security classification than is normal for civil servants. Additional precautions in the security screening of staff on initial employment may be required and management should ensure that the security classifi-

cation is at a level where personnel can perform their duties without fear of compromise.

2.4.3 International aspects of service conditions

Known differences in the industrial legislation in neighbouring States often make it likely that the terms and conditions of employment will also differ considerably for ATS personnel performing identical duties. In the course of familiarization visits between units, it is inevitable that these matters will be discussed, which may give rise to industrial unrest. However, in the formulation of terms and conditions of service there are many considerations to be taken into account before any realistic comparisons can be drawn, e.g. the cost of living factor may vary considerably between neighbouring States. ATS personnel have shown themselves to be very aware of their industrial surroundings. Therefore ATS management should take steps to keep abreast of conditions and significant changes in conditions in adjoining States and with the assistance of qualified industrial and economic advisers, endeavour to quantify the variations in employment conditions and keep their staff fully informed.

Appendix A

Criteria and Methods used by Sweden for Psychological and Physiological Evaluation of Controllers

1. APPLICATION AND SELECTION FOR APTITUDE TESTS

1.1 Each new ATC course is announced in a number of newspapers. Persons having shown interest in such courses are sent application forms together with a pamphlet which contains brief information on the air traffic controller professions. Most applicants lack a thorough knowledge of the profession, therefore the pamphlet is their first contact with ATC. Knowledge of the ATC profession is of considerable importance when evaluating the motivation of the applicants.

1.2 In order to qualify for ATC training, the applicants must possess Swedish citizenship. They also need the educational qualification required for acceptance at Swedish universities.

1.3 As it is generally not possible to test all applicants, arrangements are made to test at least five to six times more applicants than the number of positions available. The criteria used in this first stage of selection are primarily school grades obtained by the applicant. In Sweden, school grades vary between 1 as the highest and 5 as the lowest grade and usually applicants with an average not below 3.0 are invited to tests, with those having obtained top grades in school receiving priority in the selection.

1.4 Besides school grades, some extra credits are accorded to applicants for participation in the aptitude test. Extensive civil or military flying experience, or military service as an air traffic controller's assistant are considered as extra credits. However, these extra credits qualify only for participation in the written aptitude test and are not taken into account in the decision whether an applicant can proceed to the next phase of the selection process.

1.5 A number of studies have shown that there is no correlation between school grades and aptitude test results. Other reasons also indicate that new ways of selection of applicants for participation in the aptitude tests should be tried. The Board of Civil Aviation therefore selects students at random, providing they have a certain minimum school grade average. This average grade must not be

below 2.5; however, extra credits will still qualify an applicant for participation.

1.6 The applicant is required to have a visual acuity and colour perception ability as required by ICAO Annex 1. Applicants with serious and obvious body or mental defects are not accepted. However, a thorough medical examination is not made until after the psychological selection process.

1.7 No applicant will receive an ATC licence before he is 21 years old. This fact, together with the required educational qualification automatically establishes a minimum age for applicants.

1.8 At present, it is not possible to establish a maximum age, but usually applicants who are older than 27 are not accepted. The Board of Civil Aviation considers age 27 as an acceptable upper age limit because it allows applicants, prior to entering ATS, to gather experience in areas of our society other than the education sector and gives them time to develop their own personality and reach a higher degree of maturity which is considered valuable for the students concerned as well as for their fellow students. However, a higher acceptance age could jeopardize the result of the training and might eventually affect the student's future effectiveness as a professional controller.

2. APTITUDE TESTS

2.1 Elements to be brought to light in the selection process have been defined jointly by experienced air traffic controllers and psychologists.

2.2 Before an applicant is accepted, he must undergo written psychotechnical tests, interviews and a practical test.

2.3 The written aptitude tests are designed to show ability in the following aspects which are considered important for air traffic controllers:

- a) flexibility and inventiveness (four different tests);
- b) logical ability (two different tests);
- c) ability of spatial notion (four different tests);
- d) observation of details (three different tests).

2.4 Tests are designed by a consulting psychological institute but they are administered by personnel from the Staff Allocation Office of the Board of Civil Aviation.

2.5 The results achieved in the written aptitude tests determine whether an applicant will be called to the so-called final aptitude test, composed of interviews and a practical test. The practical test is designed to measure simultaneous capacity. It is composed of a series of essential and non-essential information fed to the applicant from a tape recorder, some of it demanding a specific action by the applicant, who, while listening to that information is at the same time required to perform a manual task.

2.6 The interviews of applicants are conducted by psychologists, personnel from the Staff Allocation Office, and an experienced air traffic controller from a local ATS unit. The interviews are made in an attempt to evaluate the qualities of the applicant regarding, among other things, their stress tolerance, ability to co-operate, ability to take own initiatives, and their professional motivation. The most common motive for application seems to be that the profession appears "interesting" or "fascinating" to them. However, since the applicants usually have a very limited knowledge of the profession, there are difficulties at this stage in evaluating the professional motivation.

3. MEDICAL EXAMINATION

A medical examination is made after the psychological aptitude tests. Only those applicants who have already been selected for employment, plus several reserve applicants, are examined. The medical requirements in Annex 1, Chapter 6 are followed without exception.

4. ASSISTANT CONTROLLERS

4.1 The application process outlined above also applies to the selection of applicants for assistant controller positions. However, the medical requirements are not as strict as those applied to controllers but do comply with requirements for government employees in general.

4.2 After two years of service as an assistant controller, it is possible to apply for controller training. These applicants must undergo the same aptitude tests as all other applicants. In addition, these applicants are given a statement from their local ATS unit whether they are considered acceptable as controllers. At this stage applicants must meet the medical requirements in Annex 1.

5. CONCLUSIONS

5.1 The guiding principle in both recruitment and selection of ATS personnel, as well as training, is that all trainees must be able to perform accurately at any control position.

5.2 Despite the efforts made to select the individuals best suited for the education and training, a certain percentage of the students fail to become professional controllers.

5.3 Students are paid employees of the Board of Civil Aviation from the first day of training, a fact which makes the programme attractive and results in only a small percentage of resignations due to lack of interest.

5.4 The majority of students not meeting the required standards resign because of shortcomings in one or more of the factors considered important for air traffic controllers.

5.5 On the average, 30 to 40 per cent of students are women.

5.6 From October 1974 until January 1979, 227 students were accepted for training. Of these, a total of 142 (63 per cent) became professional controllers or were still in training by mid-1979. Of the 85 students who resigned, 9 resigned voluntarily, 5 resigned voluntarily following a "warning period", and 71 were requested to do so because of unsatisfactory training results.

Chapter 3

Training and Proficiency Requirements

3.1 INTRODUCTION

3.1.1 ICAO has devoted much time to the study of practices adopted in the training of technical personnel employed in civil aviation. Detailed information in respect of air traffic services (ATS) training is provided in ICAO Doc 7192, *Training Manual*, Part A-1 — *General considerations* and Part D-2 — *Air traffic controller*.

3.1.2 Formal training of ATS personnel is usually carried out in an aviation training school established by the State or in a regional training centre established by ICAO. Advantages of a centralized establishment, where training courses are provided in a number of disciplines, is that much of the technical training space and many training aids can be more fully utilized by judicious course scheduling and specialist instructors can be used to greater advantage by time sharing, e.g. meteorological (MET) instructors can lecture to ATS, ATS can lecture to aeronautical information service (AIS) and search and rescue (SAR), and

communications (COM) can lecture to all schools. The ATS curriculum should include the following:

- a) basic training;
- b) advanced training;
- c) refresher training;
- d) specialized training (radar, computer, management).

3.1.2 It is desirable that the syllabus used for training controllers be identical for civil and military personnel; the use of a common training school is also desirable.

3.1.3 A training school can also serve as an evaluation unit for development of ATS working methods, airspace organization, route structures and equipment.

3.2 FORMAL TRAINING

A curriculum for initial training of air traffic control (ATC) personnel may consist of the following:

Table 1.— Curriculum for initial training

Unit	Curriculum	Training period (approximate number of weeks)
1) Formal training school	Basic controller training	16
2) ATC unit (tower/approach/ area control)	Familiarization and initial on- the-job training	24
3) Specialized training school	Control tower and approach control training Area control training	16
4) ATC unit	On-the-job training	12
5) Additional training school	Air traffic control system training	12
6) Assigned ATS unit	Further on-the-job training for local rating	Max. 24
TOTAL		104 weeks (2 years)

3.2.1.1 Synthetic training devices, mock ups and, where necessary, radar simulators for aerodrome control, approach control (APP) and area control centre (ACC), are useful training aids. Their use makes it possible to render training more realistic and reduces on-the-job training time.

3.2.2 Where flying training is included in the student curriculum, its aim should be the qualification as a commercial pilot as regards knowledge of the rules of the air, ATC, navigational aids, meteorology, altimetry, communication and aircraft performance. Flying training itself can normally be limited to that required for a private pilot licence but may include additional instrument flight time. Should a student fail to cope with the practical flying training it is usual to reassess his aptitude and abilities. Where no flying training is provided, adequate instruction in the above subjects should be included in the training curriculum.

3.3 ON-THE-JOB TRAINING

3.3.1 On-the-job training is aimed at permitting the new employee to integrate his basic knowledge with actual practice. It should concentrate on specific local conditions and offer opportunities to perform the functions of each operating or duty position under actual conditions and with adequate supervision.

3.3.2 Training of individuals should be a continuing process. Wherever possible, supervisors of shifts should arrange the duties of their personnel in such a manner as to enable a maximum amount of on-the-job training to be accomplished. It is desirable that as soon as an individual has obtained a rating for one position, training for the next higher grade should begin. By this means, a supply of adequately rated staff to fill vacancies at all controller positions can best be assured.

3.3.3 On-the-job training is arranged by attaching the individual concerned, whether a basic trainee or otherwise, as a supernumerary to the operating position for which he will later be rated. He is then trained by the assigned occupant of that position, or by attachment to a training officer especially appointed for this purpose. Training is continued until the trainee has reached the standard necessary for the issue of the licence and appropriate rating. The training officer should certify the competence of the trainee before the licensing authority issues the licence and rating.

The level of competence expected is that where the trainee will be able to operate without supervision.

3.3.4 Personnel who are transferred to units (other than to ACCs handling important traffic demands) are normally considered to have acquired the necessary ability to perform their duties after a minimum time of familiarization. Their need for on-the-job-training may therefore be significantly less than that required by staff assigned to a major ATC unit.

3.3.5 A new employee's first impressions will have an important bearing on his work attitude and subsequent development. Adoption of the following procedure should help to create the proper impression in the minds of new employees:

- a) introduce new employees to other staff and indicate lines of authority;
- b) give information on amenities, transport (if necessary) and show the layout of the new environment, including related offices;
- c) give information on hours of work, shift changes, and methods of making shift assignments;
- d) assign the new employees to a training officer and outline the training programme arranged for them.

3.3.6 The following is a guide to the appropriate work aspects which should be covered in a syllabus for on-the-job training. The extent to which this guide is applied will depend, of course, on previous experience and on the formal training already received by the trainee concerned:

- a) brief description of the organization of the department;
- b) detailed description of the ATS organization;
- c) a description of the services provided by the unit as a whole; where possible this should include familiarization visits to local associated units, e.g. MET;
- d) explanation and demonstration of the equipment to be used;
- e) explanation of the publications with which the employees undergoing training must be conversant for the performance of his duties;
- f) explanation of the co-ordination necessary between the operating positions in the unit, providing different services;
- g) description of the available radio navigation aids and, where applicable, a demonstration of the facilities for monitoring these aids;
- h) description of airspace, air route network, aerodrome and organization of the flight information region (FIR);
- i) characteristics of the aircraft types normally operating in the area of responsibility of the ATS unit concerned;

- j) local and regional SAR procedures and emergency procedures;
- k) familiarization tour of the ATS unit and its surroundings to the extent that this is required for the efficient performance of the assigned duties.

3.3.7 Supervisors should recognize that new employees undergoing on-the-job training may lack aeronautical experience, therefore they should be directly supervised when assigned to control duties until the licence and appropriate rating have been issued. Before on-the-job training is completed and a trainee is cleared for controller duties, it is essential to ensure that his training experience is sufficiently varied to enable him to handle all types of traffic situations likely to be encountered at the unit.

3.3.7.1 Supervisors, engaged in on-the-job training, should endeavour to conduct this training in a logical pattern so as to build up the trainee's confidence and to familiarize him with his work and environment in the shortest possible time. Care should be taken in the first place to attach the trainee to a controller with whom he is likely to establish good personal relations. Success is not likely to be achieved, for example, by placing a trainee who is expected to progress slowly or who is clearly under-confident, with a controller who is known to be impatient.

3.3.7.2 In developing a unit training programme, the following points, which are by no means exhaustive, should be considered:

- a) provide the trainee with a written unit training guide;
- b) explain to trainees the objectives of the training;
- c) before commencing training, list each step of the work in logical sequence, emphasizing any points which tend to make the work safer or easier;
- d) programme the training in such a way that theoretical aspects of the work (phraseology, separation standards, etc.) can be fitted in during quiet traffic periods;
- e) programme in easy steps, bearing in mind that what is familiar to the instructor is strange to a trainee;
- f) make clear to trainees a willingness to answer questions, or discuss suggestions;
- g) prepare the working position the way it is expected to be maintained;
- h) introduce the trainees to an operating position and put them at ease. Stress the importance of the work and try to find out what is already known;
- i) demonstrate and explain one part of the task at a time, being careful, at this stage, not to overload trainees with too much information;

- j) permit trainees to take over the duty position under close supervision. Frequently check knowledge of significant aspects of the job by questioning;
- k) as trainees progress, supervise at a distance, always being ready to advise and assist without destroying initiative by hovering over them;
- l) do not leave trainees in doubt as to how they are performing. Compliment them if they are improving; but if their progress is slow do not criticize in any way that will damage confidence. However, if a trainee is over-confident, it is sometimes salutary to increase workload, or to emphasize that over-confidence invites operational danger;
- m) when satisfied that trainees are sufficiently advanced, supervise as unobtrusively as possible so that they may learn to work independently;
- n) finally, advise the responsible supervisor when specific trainees are ready for rating examination.

3.4 PROFICIENCY TRAINING

3.4.1 It is the responsibility of the unit chief controller to establish and maintain unit proficiency standards. Guidelines specifying the required level of knowledge both theoretical and practical should be formulated by the ATS authority. Guidelines for proficiency training assessment and evaluation are provided in Appendix A.

3.4.2 All operational personnel at a unit should be required to periodically demonstrate that their on-the-job performance meets the required proficiency standards.

3.4.3 At larger units, ATS personnel specially trained in on-the-job supervision and personnel training and assessment (evaluation officers), should be employed to carry out this task for a unit. Evaluation officers should prepare proficiency check rosters so that all staff are screened on a regular basis. Operating personnel should be given advanced notice of a proficiency check so that adequate preparation, mentally and functionally, can be made.

3.4.4 At smaller units, the unit chief controller or his deputy should personally perform these duties. Where arrangements are less formal, by virtue of the size of the unit and number of staff, it should nevertheless be ensured that proficiency checks are complete and thorough.

3.4.5 Should it be found in the course of a performance check that a controller is assessed as unsatisfactory, his rating should be suspended and an appropriate refresher

and re-rating course arranged for him. Under no circumstances should any person assessed as unsatisfactory be permitted to continue on the job without supervision. If, after a reasonable period, a person is unable to pass the proficiency check, all details pertaining to the unsatisfactory assessments should be assembled and sent to the administering authority.

3.4.6 Unit chief controllers and evaluation officers should, at all times, be alert for signs of stress in a staff member and should not hesitate to provide relief. At this stage, an informal discussion by a supervisor with an employee can often avoid a progressive loss of confidence and ultimate loss of proficiency. It may also enhance safety of the operation of the unit concerned.

3.5 MANAGEMENT TRAINING

3.5.1 Management and other advanced training for ATS personnel are part of a continuing training system designed to prepare suitable personnel for higher level appointment. It is unrealistic to expect that an individual controller who, by the nature of his job, is not exposed to management, organizational or administrative duties, will be able to assume these responsibilities successfully without adequate specialized training. A typical, progressively arranged, advanced course schedule is shown in Figure 1.

3.5.2 Previous knowledge requirements and suggested target groups for advanced and management training are as shown in Table 2.

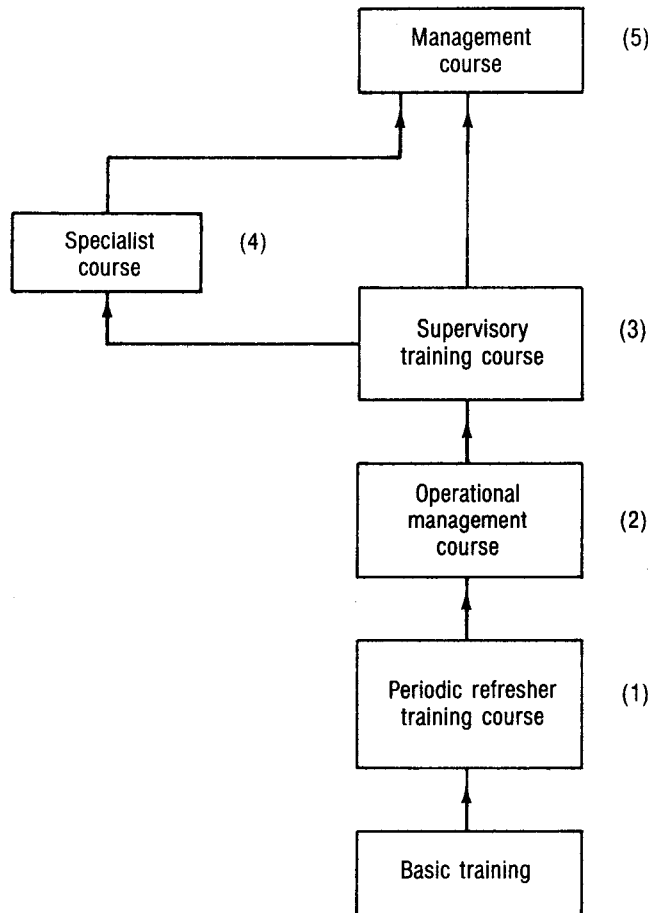

Figure 1.— Advanced course schedule

Table 2.— Previous knowledge requirements

Type of course	Previous knowledge requirements	Target group
1) Periodic ATS refresher training course	Practical experience in ATS for up to five years	Practising controllers who are on duty in ATS system
2) Operational management course	Advanced knowledge in ATS	Controllers due for promotion
3) Supervisory course	Extensive experience in a wide range of ATC functions	Potential candidates for supervisory positions
4) Specialist course	Known experience and inclination towards the special field in question	Controllers intended to assume special functions in ATS
5) Management course	Practical experience in directing an ATC unit or in training	Unit chiefs and deputy chiefs, teachers, etc.

3.6 FAMILIARIZATION FLIGHTS

3.6.1 The objective of familiarization flights is to provide an opportunity for controllers, supervisors and ATS management personnel to observe, at first hand, the working environment of pilots of large commercial aircraft and the methods and procedures used in the departure, en-route and arrival phase, including navigation techniques used. Familiarization flights also provide the opportunity to listen to air-ground communications and to assess how they affect a pilot's workload as well as the opportunity to monitor how well ATS units are performing.

3.6.2 Subject to economic and staffing considerations and agreement by operators concerned, ATS authorities should make arrangements for controllers to undertake familiarization flights aboard both scheduled and non-scheduled commercial aircraft. As these flights require entry into the cockpit of the aircraft, permission to do so should be obtained from the operator concerned prior to the flight.

3.6.3 Where familiarization flights are considered an operational requirement, they should be carried out in duty hours and taken as part of on-the-job training. Their frequency should be dictated by operational considerations. For administrative purposes flights should include operations both during day and night; however, such flights should be completed normally within one day. A written report should be submitted on the completion of a familiarization flight.

3.6.4 A familiarization flight programme for ATC operating personnel may be as follows:

- a) aerodrome controller or approach controller — Familiarization with the geographical features, significant points of his area of responsibility and standard instrument approaches to the aerodrome located in the area of responsibility. Liaison visits to neighbouring aerodromes;
- b) area controller — Flight on a controlled ATS route in the area for which his ACC is providing service; familiarization with geographical features and significant points. Liaison visits to important aerodromes located in this area of responsibilities.

3.6.5 A familiarization flight programme for supervisory personnel may be as follows:

- a) directors of air traffic control — Flight along ATS routes or areas where special requirements exist or may exist;
- b) headquarter's chiefs and supervisors; ATC instructors at a training school — Flight along ATS routes or in areas where special requirements exist;
- c) regional senior supervisors, training and evaluation specialists — Flight along at least one main domestic ATS route of operational concern to the FIR should be made every 12 months. In addition a flight should be made on any ATS route on which a major change occurs in the route structure, including a flight on the flight deck of any new type of aircraft introduced on that route.

Appendix A

Guidelines Used by One State for Proficiency Training Assessment and Evaluation

1. INTRODUCTION

1.1 To determine whether a controller has achieved the required level of competence at the operating position for which the rating is being sought, assessments are made prior to the rating assessment or prior to the validation examination.

1.2 To determine whether a controller is maintaining the required level of competence at the operating position for which a rating is held, an assessment should be made at specified intervals for each operating position. These routine assessments should be conducted on an on-going basis during duty assignment. In addition, special assessments may be carried out on such other occasions and for such other periods as may be decided by a unit chief, or by regional or headquarters' direction.

2. SCOPE OF ASSESSMENT

2.1 Personnel are assessed in key elements of the performance areas detailed on an assessment form and in accordance with an assessment guide.

2.2 An assessment should be made of both the quality of work and the level of knowledge of the elements assessed.

2.3 The person conducting the assessment should record the assessment on an appropriate form, together with relevant remarks and any discrepancies noted. Assessments should be retained on the controllers' unit training record.

3. PROFICIENCY CHECKS AND ROUTINE ASSESSMENTS

3.1 General principles

3.1.1 Proficiency checks are part of the process of assessing efficiency of personnel and should be conducted progressively throughout the year.

3.1.2 The assessment system should not be directed at fault finding, but should be an objective and constructive means through which individual controllers are encouraged and led towards higher personal achievement.

3.1.3 For each controller, a proficiency assessment record should be maintained and each record should record the objective and impartial judgement of an individual's ability based on regular checks and continuous observation.

3.1.4 The acceptance of proficiency checks as a process of personnel assessment and development is determined to a large degree by the objectivity, honesty and integrity with which the checks are administered and the degree of participation and protection afforded the individual controller. Counselling is an important feature in controller development and therefore controllers undergoing the assessment should be made aware, by formal and informal counselling, of the assessments and remarks made by the assessing officer on the proficiency assessment record. Strengths as well as weaknesses should be discussed with the controller.

3.2 SYSTEM OPERATION

3.2.1 Should a controller perform his duties in a manner which causes doubt as to the acceptable standard of his performance, an assessment may be made at any time irrespective of the period of time that has elapsed since the completion of the last preceding assessment. This assessment should require the controller to demonstrate an acceptable standard of performance and knowledge in each of the key elements in his performance which are being checked.

3.2.2 When corrective training is indicated, the assessing officer should record on the assessment record whether the controller is competent to continue performing operational duties while he is under training. Should the assessing officer consider that the controller being assessed is not competent, the unit chief controller should be notified immediately.

3.2.3 An oral examination conducted by the assessing officer may be used to determine the level of knowledge in the key aspects of the rating which is being assessed. The oral examination should be conducted separately from the practical assessment.

4. CHECK/ASSESSMENT GUIDE

The following points should be considered when assessing the individual performance of a controller:

- a) aerodrome/approach/area procedures:
 - 1) knowledge of separation standards and their application;
 - 2) recognition of aircraft capabilities, i.e. differences in speed, climb, descent, altitude requirements, take off/landing requirement, engine failure performance, and other differences of performance;
 - 3) awareness and analysis of traffic situations;
 - 4) planning, sequencing and expedition of the traffic flow;
 - 5) adjusting traffic to changing conditions in case of radar failure, radio aid failure, changes in flight rules, aerodrome closures and diversions;
 - 6) use of local procedures such as selection of runways, noise abatement procedures, departure and instrument approach procedures;
 - 7) co-ordination with other sectors/units, including methods of transfers and updating of information;
 - 8) utilization of radar;
 - 9) composition of clearance in respect of contents, clarity, conciseness and expedition.
- b) Flight information procedures:
 - 1) receipt, recording and checking of flight plans;
 - 2) issuance of essential flight information including meteorological information and information on collision hazards;
 - 3) passing of clearances and flight information to aircraft, including their correctness, identification of originators and, where necessary, time limitations;
 - 4) recognition of aircraft capabilities (see 4.1 a) 2));
 - 5) knowledge of local procedures (see 4.1 a) 6));
 - 6) co-ordination procedures with other ATS units.
- c) Radar procedures:
 - 1) methods of identification of targets including those used in case of misidentification, re-identification after fade area, blind velocity and merging of targets;
 - 2) adherence to prescribed separation standards;
 - 3) recognition of aircraft capabilities (see 4.1 a) 2));
 - 4) composition of clearances when using radar;
 - 5) radar control of arriving traffic, its sequencing, vectoring and provision of adequate terrain clearance;
 - 6) radar control of departing traffic including radar releases and traffic expedition;
 - 7) radar control of overflying traffic including vectoring;
 - 8) methods of transfer of radar control including instructions to aircraft, transfer of control to final radar controller and transfer of control to aerodrome control;
 - 9) provision of radar position information to aircraft;
 - 10) provision of radar-derived navigation assistance to aircraft;
 - 11) provision of radar-derived traffic information including the use of such information, its necessity and need for unambiguity;
 - 12) provision of radar-derived assistance to aircraft in emergency;
 - 13) co-ordination with other sectors/units (see 4.1 a) 7)).
- d) Radar approaches:
 - 1) conduct of surveillance radar approaches, their accuracy and positioning, their sequencing and issue of advice on minimum altitudes;
 - 2) conduct of precision radar approaches, their accuracy and positioning on prescribed glide path, co-ordination with tower and radiotelephony (RTF).
- e) Radar equipment:
 - 1) equipment operation and alignment including setting up and check procedures, level of brilliance, video map, range rings, and checking accuracy of map;
 - 2) recognition of types of interference including those caused by terrain and weather, blind velocity, tangential velocity, etc.;
 - 3) recognition of fade areas and application of possible counter measures.
- f) Radio and telephone:
 - 1) use of correct procedures and phraseology, knowledge of coverage limitations, call signs, abbreviated procedures, phraseologies, unnecessary repetitions, and use of correct position identifier;
 - 2) clarity, modulation, speed, diction and evenness of voice communications;
 - 3) promptness of response, confidence and avoidance of uncertainties;
 - 4) adequacy of monitoring of air-ground communication channels;
 - 5) courtesy, attitude, and co-operativeness in telephone communications.

-
- g) Data display:
- 1) posting and updating of flight data and other relevant information;
 - 2) acceptance and use of meteorological reports;
 - 3) dissemination of meteorological reports to aircraft.
- h) Loss of communication and alerting service procedures:
- 1) recognition and response to loss of communication situation and promptness of action;
 - 2) response to likely emergency situations;
 - 3) use of correct emergency procedures — type of emergency, appropriateness of procedures;
 - 4) declaration of alerting phases and co-operation with SAR services;
 - 5) action in performance of local operating procedures;
 - 6) response to cases of unlawful interference with aircraft.
-

Chapter 4

ATS Licences and Ratings

4.1 INTRODUCTION

4.1.1 Standardization of procedures and methods regarding the recruitment, training, performance and, where required, licensing of air traffic services (ATS) personnel is essential in a service which has international obligations and uses procedures involving more than one unit. The degree of standardization achieved is directly related to the proficiency with which individuals perform their duties. This condition in turn determines the efficiency of the service given to the users and to the travelling public.

4.1.2 Individual proficiency is attained and maintained by a programme of training, proficiency evaluation checks and routine assessments, and, most essentially, by the deliberate and conscientious efforts of all ATS personnel.

4.1.3 While it is recognized that State employees may operate as air traffic controllers without a licence, provided they meet the requirements for this profession set out in Annex 1 — *Personnel Licensing*, it has nevertheless been found that most States prefer to issue such licences even to their State employees acting in this capacity. This is mainly due to the fact that it has been recognized that this will assist in maintaining the level of confidence required to ensure collaboration between ground services and operators and/or pilots under the best possible terms, especially when such collaboration involves persons of different nationalities, backgrounds and mentalities. It is for this reason that the material presented hereafter has been based on the assumption that States are applying the practice of issuing personal licences and ratings to each person required to act as an air traffic controller.

4.1.4 The air traffic controller licence does not by itself entitle the holder to provide ATS to aircraft. The provision of such services at specific locations or within specific areas, or its performance with the aid of special tools such as radar requires additional knowledge and/or skills related to existing local conditions, or to the tool in question. The evidence of the necessary knowledge and/or skills is provided by an appropriate rating certifying that the additional knowledge and/or skills have been acquired

to a degree necessary for the safe performance of the assigned duties. Such ratings must be entered on the licence of the person concerned.

4.1.5 The requirements for the issue of an air traffic controller licence and for rating should conform to the applicable provisions in Annex 1.

4.2 REQUIREMENT FOR AIR TRAFFIC CONTROL LICENCES

Annex 1 sets out the requirements for the issue of an air traffic controller licence including the medical fitness requirements. Procedures to be followed in this respect should cover the following points:

- a) detailed requirements for the issue of a licence;
- b) issue, retention and withdrawal of licences;
- c) validity of the licence and rating;
- d) privileges of the holders of a licence and rating;
- e) medical requirements for the issue of a licence; and
- f) requirements for the renewal of the medical assessment.

4.3 REQUIREMENT FOR AIR TRAFFIC CONTROL RATINGS

4.3.1 Before an individual can operate as an air traffic controller, he must, in addition to possessing a valid licence, hold a valid rating or ratings relevant to the location, operating position and/or the specific equipment used in the exercise of his functions. If he is employed by a State which does not license its employees, then the State must ensure that the controller meets qualifications equivalent to those for the issue of the licence or rating.

4.3.2 The requirements for the issue of air traffic controller ratings and the privileges which may be exercised

with such ratings are set out in Annex 1. The ratings refer to the following specific services and/or locations:

- a) aerodrome control;
- b) approach control;
- c) area control;
- d) radar.

4.3.3 The ATS authority should, at the national level, establish the general provisions relating to ATC ratings. Local ATS units should develop appropriate training syllabi for all operating positions for which a rating(s) may be required. Appendix A shows an example of requirements for ATC licensing and rating. Appendix B shows an example of provisions relating to ATC ratings.

4.4 RATINGS FOR SENIOR AND SUPERVISORY PERSONNEL

4.4.1 Unit chief controllers and the evaluation and proficiency specialist for the unit may be exempt from the requirements to hold valid ratings. However, the following provisions should normally apply:

- a) they must, at one time, have held valid procedural and radar ratings appropriate for the unit of which they are in charge or where they are assigned;
- b) they must keep themselves adequately aware of the unit's level of activity at all hours of operation. To give effect to this they should ensure that their duty schedule provides for frequent visits to the operational area of their unit throughout the watch and during peak traffic periods.

4.4.2 Evaluation and proficiency specialists and unit chief controllers, on taking up appointment, should obtain or re-validate all ratings required in that unit. Operating proficiency should be maintained in at least one of the operating positions. From time to time they should be required to assume watchkeeping duties at that position to maintain their competence.

4.4.3 Shift supervisors, on taking up appointment, should obtain or re-validate all ratings required in that unit and operating proficiency should be maintained in each operating position. They should also assume watchkeeping duties as necessary to maintain the validity of their ratings. Shift supervisors should not assume watch supervision until they hold valid ratings for all operating positions in that unit.

Appendix A

Provisions Regarding Air Traffic Controller Licences

1. ISSUE OF A LICENCE

In order to qualify for the issue of an air traffic controller licence a person must meet the knowledge and medical fitness requirements set out in Annex 1. In addition, in order to exercise the privileges of an ATC licence, a person must hold a valid rating which is related to a specific unit and/or operating position or to the use of specific equipment (e.g. radar).

2. RETENTION AND WITHDRAWAL OF LICENCES

The ATS authority will issue air traffic controller licences to specific persons having met the requirements for such issue. Once issued, a licence shall be retained by the person to whom it has been issued and be available for presentation on demand whenever the privileges of the licence are being exercised. A licence may be withdrawn only by the issuing authority.

3. PRIVILEGES OF A LICENCE

In addition to the valid licence and subject to compliance with other relevant conditions specified in appropriate national regulations, the holder of an air traffic controller licence is authorized to perform such air traffic controller duties at units and/or operating positions for which he holds a valid rating or ratings.

4. VALIDITY OF LICENCE

4.1 A licence should specify a period of validity and remains valid only while its holder meets all requirements upon which the validity of the licence has been made dependent, including those for medical fitness.

4.1.1 An air traffic controller is not authorized to exercise the privileges of any rating if the period of validity of his licence has expired.

4.2 Notwithstanding the provisions in 4.1, the holder of an air traffic controller licence should not exercise the privileges of any rating in his licence during any period in which his medical fitness has, from whatever cause, decreased to the extent that this condition would prevent the issue or renewal of his licence, nor should a controller exercise the privileges of any rating in his licence during any period when he is aware of any temporary decrease in medical fitness which renders him unable to meet the medical requirements for the issue or renewal of his licence.

4.2.1 A decrease of medical fitness can result from disease, injury or the effects of alcohol or drugs. The term "drugs" is to be interpreted in the widest sense and includes not only narcotic drugs but also prescribed medication, tranquillizers, etc. An assessment of this condition may render the holder of the licence incapable of meeting the requirements for the issue of the licence.

4.2.2 Certain medicinal drugs may produce side-effects which can interfere with the safe performance of duty. Continuing use of medication must be proven as acceptable over a reasonable period of time prior to the re-assessment of fitness or the controller may be temporarily disqualified from performing the ATC duties for which he is licensed.

4.3 An air traffic controller should not perform the duties for which he is licensed and rated during that period when he suffers from a temporary incapacity resulting from injury or illness and likely to impair his efficiency.

4.4 Where incapacity causes the holder of an air traffic controller licence to temporarily cease performing duties pertaining to that licence, the holder of the certificate should not resume his duties until a qualified medical practitioner has issued a certificate (stating diagnosis) confirming that the person concerned has fully recovered from the incapacity.

4.5 Unit chief controllers should ensure that, at no time, a controller is permitted to exercise the privileges of any rating in his licence when the period of validity has expired,

or when he fails to maintain competence, or when the provisions of 4.2 or 4.3 apply.

4.6 Unit chief controllers should inspect the licence of each air traffic controller arriving at a unit on transfer, or temporary duty, to ensure that the licence is valid and to determine the extent of training which will have to be undertaken before the controller can be permitted to assume unmonitored watchkeeping duties.

5. MEDICAL FITNESS AND RENEWAL OF A LICENCE

5.1 To assess medical fitness prior to the renewal of a licence, an air traffic controller should undergo an appropriate medical examination. The same provision should also follow any period during which a controller's licence has been invalidated for medical reasons.

5.2 Air traffic control personnel, including trainees, should be responsible for arranging their own medical examinations. At ATS units a record should be established and maintained to serve as a reminder to controllers to ensure that periodic medical examinations are completed within a specified period so that licences may be renewed prior to their respective date of expiry. This record should serve to give controllers concerned an initial notification at least two months prior, and a check one week prior to the date of expiry of their licence to ensure that the required medical examination has been completed. Although such a method places a responsibility on the ATS unit to ensure

that reminders are issued, the primary responsibility to take a required medical examination within the specified period rests with the individual concerned.

5.3 The renewal of a licence should be withheld if the medical requirements are not attained. However, a licence may be renewed if the conditions specified in Annex 1 are met. In applying these provisions, the licensing authority should, in each case, give careful consideration to striking a reasonable balance between the obligation not to jeopardize flight safety by permitting a slightly medically deficient controller to perform ATC duties on the one hand and, on the other, the possibility that at least some of the medical shortcomings may be compensated for by:

- a) the ability, skill and experience of the controller concerned;
- b) the prescription of compliance with special limitations for the controller concerned while on duty (e.g. wearing glasses and having spare glasses handy, etc.);
- c) arrangements in the operating environment of the controller concerned which prevent his exposure to situations where his known shortcoming may affect the performance of his duties.

In addition, when it is necessary to apply the above provisions, the full medical assessment should be made, taking into consideration performance in the operational environment.

5.4 It shall be the responsibility of the controller whose licence is endorsed with any limitations resulting from the application of the provisions in 5.3 to comply with such special limitations while on duty at any operating position.

Appendix B

Provisions Regarding Air Traffic Control Ratings

1. VALIDITY OF RATINGS

1.1 An ATC rating is valid only for the location and operating position entered on the valid licence.

1.2 Any rating should become invalid when the holder has not exercised the privileges of the rating for a specified time and remain so until such time as the holder has met the requirements for revalidation of the rating concerned.

1.3 To qualify for the re-validation or the validation of a rating for an additional location or operating position, the applicant should meet the following requirements:

- a) *Experience.* The controller should hold, or have held, a corresponding rating for another location or comparable operating position and have completed sufficient training at the new location or operating position for which the re-validation/validation is sought.
- b) *Skill.* The chief controller of the ATS unit for which the re-validation/validation is sought should certify that he is competent to exercise the privileges of the rating.
- c) *Knowledge.* The controller concerned should be given an oral examination on those subjects which are relevant to local conditions and the rating sought.

1.4 An air traffic controller, required to man an operating position only occasionally, should be required to spend sufficient time at that operating position in order to maintain a satisfactory level of proficiency.

1.5 An air traffic controller who is not proficient should not exercise the privileges of the rating at the particular operating position until he has demonstrated the required ability under supervision. When he is considered proficient, this fact shall be recorded in the appropriate ATS log.

2. EXAMINATION PROCEDURE

2.1 The oral examination should consist of general questions on basic knowledge and take account of ques-

tions on specific knowledge associated with the rating being sought. In addition, the examiner(s) may include such additional relevant questions as may be considered necessary.

2.2 To pass the oral examination an applicant should obtain a predetermined mark. Notwithstanding the mark obtained, an applicant whose knowledge is deficient in respect of critical aspects may be failed, or he may be required to meet such additional conditions as appear necessary.

2.3 At the discretion of headquarters, a controller who fails to pass the oral examination for the issue of a rating may be given a further opportunity of qualifying, provided that, after due consideration of reports, assessments and recommendations of the examiner(s), the controller is considered suitable for eventual performance of the type or types of duties concerned.

3. PREPARATION OF EXAMINATION MATERIAL

3.1 Questionnaires on basic knowledge should be prepared for rating and validation examinations and copies of this material should be available at units where personnel are undergoing training. Their use in the unit is to be restricted to assist questioning by the unit chief controller or unit evaluation personnel in order to determine the level of basic knowledge of controllers prior to examination. Attachment 1 contains a list of subjects for basic knowledge questions and lists the areas where they may be used in the rating process.

3.2 Unit chief controllers should prepare and maintain a questionnaire, complete with answers, on the specific local knowledge required for each type of rating in their unit. These questionnaires should be based on local operating instructions or other relevant material.

AIR TRAFFIC SERVICES PLANNING MANUAL

PART IV

**SECTION 2. ATS FACILITY ADMINISTRATION
AND MANAGEMENT**

SECTION 2

ATS FACILITY ADMINISTRATION AND MANAGEMENT

Contents

	<i>Page</i>		<i>Page</i>
Chapter 1. Functional Management	IV-2-1-1		
1.1 Introduction	IV-2-1-1		
1.2 Operational line of authority	IV-2-1-1		
1.3 Functional organization of ATS units ..	IV-2-1-1		
1.4 Job descriptions and responsibilities ...	IV-2-1-2		
1.5 Hours of operation and duty schedules	IV-2-1-2		
1.6 Opening and closing a watch	IV-2-1-3		
1.7 Transfer of watch responsibilities	IV-2-1-3		
1.8 Air traffic services log	IV-2-1-4		
1.9 Unit operating instructions	IV-2-1-5		
1.10 Letters of agreement and operations letters	IV-2-1-5		
1.11 Facility security	IV-2-1-6		
		1.12 Personnel security	IV-2-1-7
		1.13 Arrangements for visitors	IV-2-1-7
		Appendix A. General guide to good management practices	IV-2-1-8
		Appendix B. Job descriptions of posts in ATS	IV-2-1-9
		Chapter 2. Co-ordination	IV-2-2-1
		2.1 Introduction	IV-2-2-1
		2.2 Co-ordination with operators, airmen and others	IV-2-2-1

Chapter 1

Functional Management

1.1 INTRODUCTION

Further to the organization of the air traffic services (ATS), described earlier in Part IV, Section 1, Chapter 1, the material that follows is concerned with the functional management of ATS units at the unit level. Appendix A provides a guide to good management practices.

1.2 OPERATIONAL LINE OF AUTHORITY

1.2.1 To ensure the sound administration and management of facilities clear lines of operational authority from headquarters to the region or field, and from regional or field headquarters to units and controllers need to be established.

1.2.2 The staff functions of personnel at headquarters or regions should not be confused with the functions of personnel at the ATS unit level. Policy directives, operating instructions, unit reports and other information must flow freely and quickly from management to personnel at ATS unit level.

1.2.3 In ATS matters, regional chiefs should be directly responsible to the headquarter's divisional director. Chiefs of area control centres (ACCs), approach control (APP) offices and aerodrome control towers should be responsible to the regional chief while watch supervisors and evaluation and proficiency supervisors should be responsible to the unit chief controller. Individual controllers should report to watch supervisors, or, where none are envisaged, to the chief of the ATS unit concerned.

1.2.4 Delegation of work is important if personnel in supervisory positions are not to become overloaded. However, when a significant responsibility is delegated it should be done in writing and clearly state the level of management to which the delegation extends.

1.2.5 Specialist staff officers at headquarters or regional level should be authorized to communicate directly with unit chiefs in matters within their competence and unit chief controllers should likewise be authorized to approach specialist staff officers directly for technical advice and information. Should it be found that, in the course of such contacts, matters of significance arise, these matters should be made subject to formal processing.

1.2.6 Direct access to senior management should be available to all staff in matters of a strictly personal or private nature. In all other matters personnel should be required to forward correspondence, addressed to a higher level, through proper channels. Supervisors should comment on such correspondence as appropriate and dispatch it with the minimum of delay.

1.2.7 Personnel at all levels should profit from rapid and accurate transmittal of administrative and management information. Lines of communication should be kept open at all times and involve the least possible number of personnel, thus facilitating dialogue between senior management and field units.

1.3 FUNCTIONAL ORGANIZATION OF ATS UNITS

1.3.1 The organization of the ATS may vary from State to State depending on the level of flying activity. However, regardless of the size of an ATS unit, the organization of the functions follows an established pattern.

1.3.2 ACCs, responsible for en-route service to aircraft, are organized in relation to the density and flow of movements within the established ATS route network for which they are responsible. As the flow and density of traffic increase, controller activities are arranged so that they manage sectors of airspace which may be divided geographically, e.g. North and South sectors, or vertically, i.e. high, medium and low level sectors. Sectorization

relieves congestion. Sectorization is generally arranged so that like functions are grouped together so as to facilitate co-ordination between operating positions and enable supervisors to monitor the total situation. In ACCs where radar is used, it is usual to provide a radar monitor at the watch supervisor's desk for random monitoring. Other matters to be taken into account in the organization of the functions of ACCs concern the ready availability of flight data which requires the collocation of assistant and controller positions in the most convenient manner. The provision of a flight information service to visual flight rules (VFR) or non-controlled flights within the flight information region (FIR) may be an integral function of the ACC or, in particularly busy ACCs, may be operated in adjacent premises under separate supervision. In either case intercommunication with related control activities is essential. Area control functions may also be exercised by an APP unit when there is no requirement for the establishment of a separate ACC either by reason of limitations of airspace or low density traffic.

1.3.3 An APP office is normally responsible for the separation of aircraft operating in accordance with the instrument flight rules (IFR) within a defined airspace around an aerodrome. This service may be provided by procedural and/or radar methods. The functional organization of an APP resembles that of an ACC except that, when traffic density requires sectorization, it is more common to sectorize with respect to entry/exit routes than geographically or vertically. APP functions may be combined either with an aerodrome control tower or with an ACC where the traffic density does not warrant the establishment of a separate unit.

1.3.4 An aerodrome control tower provides control service to all aircraft manoeuvring on the aerodrome, to arriving and departing aircraft, and to aircraft flying in the vicinity of the aerodrome. The controller responsible for the control of landing and departing aircraft is the key member of the operating team, and must be assured of sufficient support from appropriately qualified personnel so that he is not distracted from his primary task. Except at low and medium traffic density aerodromes, the chief controller of an aerodrome control tower is not normally directly involved in active controlling duties because of the necessary involvement in the many and varied duties concerning all facets of flight operation so that responsibility for the operation of the aerodrome control tower is normally delegated to the most senior controller on duty who also co-ordinates the over-all workload. In circumstances where a control tower is also providing APP, supervision of operations may become so important that a separate supervisor has to be provided to ensure adequate and timely co-ordination between the two functions.

1.3.5 The maximum use of a standard equipment layout at units providing similar service will help improve functional efficiency and unit chief controllers or their designated representatives should be given the opportunity to participate in meetings where changes and improvements to the layout and equipment of facilities can be discussed.

1.4 JOB DESCRIPTIONS AND RESPONSIBILITIES

1.4.1 At each ATS regional headquarters an ATS operations officer responsible for the efficient operation of ATS within the region should be appointed and ATS units should be classified according to their relative level of activity in relation to one another, e.g. high traffic density units would be those where large numbers of aircraft are handled while the designations of intermediate or low density units would indicate a decreasing order of ATS activity.

1.4.2 Chief controllers of ATS units should be responsible for the efficient provision of ATS at their units. Evaluation and proficiency development staff should be attached to Regional Offices and high traffic density units. They should be responsible for the training of ATS personnel and for ensuring that standard procedures and methods are practised within the unit concerned. At smaller ATS units, where the establishment of separate staff for this task is not warranted, their duties should be assigned to other qualified personnel.

1.4.3 Where provided, watch supervisors should be responsible for the supervision and co-ordination of all operations within the unit concerned during their tour of duty.

1.4.4 Air traffic controllers may be divided into those applying procedural control only and radar controllers. Supporting personnel at ATS units also includes assistants responsible for the collocation of flight data and essential flight information. Job descriptions outlining some of the duties and responsibilities of the various positions described above are shown in Appendix B.

1.5 HOURS OF OPERATION AND DUTY SCHEDULES

1.5.1 Operators engaged in recurrent pre-planned flight operations should provide information on such flights to

the ATS authority to enable it to make a more accurate assessment of the required duty schedules and to have information on which to establish the hours of operation of those ATS units not required to operate on a continuous basis. However, in this context, consideration must also be given to general aviation operations. Criteria which may be used in this respect are listed below. These points should be used in conjunction with the industrial conditions of employment pertaining to ATS personnel:

- a) the assessment of the required duty schedules should take into account the following factors in determining the basic operating hours of individual ATS units;
 - 1) information provided by operators conducting regular commercial transport flights;
 - 2) information provided by other users engaged in recurrent pre-planned flight operations;
 - 3) information on general aviation operations.
- b) the review of this flight operations information, both as regards origin and destination as well as frequency of operations, in conjunction with the industrial conditions of employment of ATS personnel, should serve to determine the hours of service of ATS units, except those which as a consequence of agreed international or national obligations, are required to operate on a continuous basis;
- c) additional criteria which, in the case of APP and aerodrome control tower units, may need to be taken into account in the assessment are:
 - 1) the requirement to provide approach control service for an adjacent aerodrome;
 - 2) the requirement to keep an aerodrome open because it serves as a designated alternate for flights to other destinations;
 - 3) the requirement to provide ATC to overflights within portions of controlled airspace which have been permanently assigned to an APP unit.

1.5.2 The promulgated hours of service are minimum hours and may not be reduced except in an emergency, or where there is no practical alternative or when it is known that no further requirement for service exists, e.g. at night when the last scheduled flight on which close-down time is based is cancelled. In cases where a reduction is unavoidable during promulgated hours and no relief is available, the associated ACC/flight information centre (FIC) should be notified as much in advance as possible and appropriate NOTAM action should be taken.

1.6 OPENING AND CLOSING A WATCH

1.6.1 In determining the promulgated hours of service, allowance should be made for a specified time before the estimated time of departure (or arrival) of the first aircraft to which the unit is required to provide service. Normally, a further specified period should be incorporated in duty schedules to allow for such activities as familiarization, facilities check and in the case of control towers, runway inspection before the unit is opened to service.

1.6.2 When the last scheduled movement of the day is an arrival, the promulgated close-down time is normally based on the estimated time of arrival plus a predetermined time. When the last scheduled movement is a departure, the promulgated close-down time is normally based on the time at which transfer of control and communications to the next unit would normally be expected to be effected and associated actions completed.

1.6.3 On opening a watch at an ATS unit other than an ACC/FIC, the controller on duty should notify the associated ACC/FIC advising it of the time the watch is opened and any significant unserviceabilities. If such advice is not received by an ACC/FIC within a specified time after the scheduled opening, the supervisor on duty in that ACC/FIC should confirm with the unit that watch has been opened and ascertain the reasons for delay in notification. In addition, any ATS unit should advise the associated ACC/FIC of any changes in closing or opening times, together with brief details, when these are different from the published hours of operation.

1.6.4 Approximately 30 minutes prior to the anticipated time of closing a watch, the ATS unit at an aerodrome serving as a possible alternate should notify the associated ACC of the intended time of closing. On receipt of this message, the ACC supervisor should ascertain whether the need for the aerodrome to serve as alternate is required any longer and confirm to the unit that it is permitted to close.

1.7 TRANSFER OF WATCH RESPONSIBILITIES

1.7.1 The hours of operation of ATS units usually require a shift change at least once a day. During such shift changes, a number of actions are to be taken to ensure continuity of operation; this applies particularly to a comprehensive hand-over/take-over procedure. Since the specific actions, which need to be taken at each unit and at each operating position, may vary, they should be specified

in unit operating instructions. The time required for hand-over at shift change will depend on the complexity of the operating position and the traffic situation at the time of the change.

1.7.2 When a controller is assigned to an operating position, he should normally not hand over responsibility for the performance of the duties associated with this position to any other controller unless he is authorized to do so by the supervisor on duty, except as provided in 1.7.6 below.

1.7.3 Before vacating an operating position for any reason while a unit is still in operation, the controller vacating that position should ensure that there is a clear understanding as to who will assume responsibility for that particular operating position and an appropriate hand-over should be effected.

1.7.4 It is essential that all controllers occupying an operating position are in a satisfactory state of health throughout their period of duty. Accordingly, a controller should not assume or retain responsibility for any ATS operating position if his capacity to perform the duties of the position is in any way impaired because of sickness, injury, alcohol, drugs, fatigue, personal worry or his emotional state. A controller who considers that his physical or emotional state is such that his ability to perform his duties satisfactorily may be impaired should notify the supervisor on duty, and that supervisor should make necessary relief arrangements.

1.7.5 Prior to taking over an operating position, a controller should:

- a) ensure that he has a full understanding of the air traffic situation including an awareness of clearances issued but not yet acted upon and any developing situation requiring early attention;
- b) familiarize himself with the serviceability of all equipment under his charge and liable to be used during his tour of duty (e.g. radar, radio, approach aids, telephone lines and aerodrome lighting);
- c) obtain all relevant information and familiarize himself with the meteorological situation and trends for his tour of duty and where practicable get a personal briefing from a meteorological office;
- d) ensure he is fully conversant with the latest promulgated orders, instructions, notices and information, particularly with reference to the serviceability of aerodromes and other air navigation facilities;
- e) sign on in the log or at the operating position, as applicable, as having accepted responsibility for the position.

1.7.6 A controller handing over watch to another person should ensure that his successor is provided with full information on the current traffic situation and any matters of significance which have influenced the development of the situation or which may have a bearing on the situation arising during the ensuing tour of duty. When a prevailing traffic situation or other event makes it desirable for a controller to complete all actions before transferring responsibility to another controller, he should remain on duty until such time as these actions have been completed. However, assembly of records or completion of reports associated with any such event should be completed after hand-over is effected but before signing off. In any case it must be ensured that responsibility for manning a position is recorded in an uninterrupted manner.

1.7.7 Should a situation arise at any time whereby a controller considers it prudent to seek advice he should notify the supervisor on duty, or, if not available, the most senior controller. If the situation so warrants, the person called upon should assume responsibility for the operating position and record that fact in the ATS log. Nothing in this paragraph should prevent a supervisor from assuming responsibility for an operating position at any time if, in his judgement, the situation so warrants.

1.8 AIR TRAFFIC SERVICES LOG

1.8.1 The ATS log serves to record all significant occurrences and actions relating to operations, facilities, equipment and staff at an ATS unit. It is an official document and, unless otherwise authorized, its contents should be restricted to those personnel requiring access to the information.

1.8.2 At units where there is more than one operating room, i.e. control cab and APP room, a separate ATS log should be maintained in each room. When an operating room is not manned on a 24-hour basis, the log should be maintained during the hours the room is used. ATS logs for operating rooms manned on a 24-hour basis, should be maintained continuously. The supervisor on duty in each operating room should be responsible for opening, closing and maintaining the log, as applicable. All entries should be made in an indelible manner and erasures should not be permitted. Incorrect information should be struck out and the correct information inserted near it.

1.8.3 The type of information to be recorded in the ATS log should, as appropriate to the operating room, include such matters as:

- a) incidents, accidents, non-compliance with regulations or air traffic control centre (ATC) clearances, regardless of whether an additional, separate report is required;
- b) aerodrome inspections, details of work in progress and other essential aerodrome information;
- c) a change in status of navigation facilities, services and procedures;
- d) time of receipt of special aerodrome reports, SIGMET reports, or any other significant meteorological phenomena.

1.8.4 Recording of information should be completed in the following manner:

- a) entries may be made by any controller on duty; a full signature or authorized initials should accompany each entry;
- b) the time of entries should be recorded in Universal Coordinated Time (UTC) or Greenwich Mean Time (GMT) and entries should be in sufficient detail to give readers a complete understanding of all actions taken. Strict attention should be given to the time an incident occurs and the time at which action is initiated;
- c) entries should be made in chronological order and, so far as is possible, concurrently with the occurrences and actions. When, during emergencies or busy times, it is not possible to make detailed entries in the log at the time of the occurrence, rough notes should be kept with exact times and a detailed log entry made as soon as possible thereafter;
- d) any entry requiring to be brought to the notice of the unit chief controller should be so annotated;
- e) at the end of the operating period, the log should be closed; in the case of units operating on a 24-hour basis, a new sheet in the log should be started at 0000 GMT.

1.8.5 The unit chief controller should review the ATS log at least once every working day, taking note of all significant entries. All personnel should read those log entries of concern to them which were made during the period since the end of their last tour of duty before accepting responsibility for an operating position.

1.9 UNIT OPERATING INSTRUCTIONS

1.9.1 While prepared under the direction of the chief of an ATS unit, ATS unit operating instructions are issued under the authority of the director of ATS. They primarily consist of procedures and instructions of a local nature which are either subject to frequent change or limited in application, but are, in all cases, supplementary to the applicable national provisions.

1.9.2 Unit operating instructions should, as necessary, contain:

- a) detailed unit operational procedures and requirements;
- b) detailed unit administrative requirements, including the responsibilities of each operating position;
- c) amplification and/or explanation of provisions of the national manual of ATS, where necessary.

1.9.3 Specific terminology should be used to differentiate between mandatory, recommended and optional application of the relevant provisions. Other terminology and abbreviations should conform to those used in other operating manuals and relevant documents.

1.9.4 In the preparation of unit operating instructions, relevant instructions contained in other readily accessible documents should only be referred to but not repeated in order to avoid the need for amendment of the operating instructions every time the quoted instructions are changed.

1.9.5 Amendments to unit operating instructions should be recorded in the document and brought to the attention of all controllers concerned in the most appropriate manner. In addition, as part of the conditions of taking over a specific operating position, controllers should be required to indicate, in an appropriate manner, that an amendment has been noted.

1.10 LETTERS OF AGREEMENT AND OPERATIONS LETTERS

1.10.1 It is accepted practice that the term “letter of agreement” is used to cover agreements between two or more adjacent ATS units or between ATS authorities of different States dealing with the manner in which ATS are to be provided by the parties concerned. The term “operations letter” is used to cover agreements between one or more ATS unit(s) on the one hand and other authorities, agencies or bodies (the military, other operators, aerodrome operators, etc.) specifying the conditions, means and procedures employed to regulate their co-operation or the conduct of specific operations affecting ATS.

1.10.2 Procedures should be established for the processing of letters of agreement and operations letters to ensure that:

- a) any action required by letters of agreement is co-ordinated with the ATS units concerned;

- b) any necessary co-ordination with other parties concerned with an operations letter is effected;
- c) the effective date of an agreement allows for at least 30 days for familiarization after distribution by all concerned;
- d) the agreement is signed by the unit chief controller and responsible personnel of other agencies/operators involved;
- e) a copy of the agreement is provided to:
 - 1) the units/agencies/operators involved;
 - 2) the director of ATS;
 - 3) if applicable, military headquarters, offices of other administrations and Regional Offices.
- c) Effective date: State when the agreement comes into force and, if relevant, when it expires;
- d) Special provisions: Include provisions regarding modification, amendment and/or cancellation of the agreement;
- e) Status: Indicate whether the letter supersedes, supplements or otherwise affects other previous agreements;
- f) Attachments: List any chart, diagram or other appendices;
- g) Signature: Include appropriate titles and signatures;
- h) For ease of subsequent reference, it may also be advisable to assign a specific number or other identifier to each letter of agreement.

1.10.3 Letters of agreement and operations letters should be reviewed frequently and amended or replaced as necessary to ensure conformity with current operational requirements, directives and policy. Amendments should be prepared and processed in the same manner as the original agreement. Agreements that are no longer applicable should be cancelled and all agencies that were provided copies of an agreement should be informed of its cancellation. Each agreement and all amendments thereto should be retained for a specified period of time after their cancellation.

1.10.4 When preparing letters of agreement or operations letters, the unit chief controller, in co-ordination with other units/agencies/operators involved, should develop the subject as follows:

- a) define the purpose;
- b) define the responsibilities of each unit/agency/operator involved if responsibility is being delegated or if the division of responsibility is not already adequately defined in a manual of operations or established by policy;
- c) if a delegation of the responsibility for airspace is involved, describe the airspace and define conditions governing its use, such as use of levels, routing restrictions, limitations and/or exceptions;
- d) describe the procedures that are required to supplement those contained in the manual of operations, establish common operating practices, or resolve differences between conflicting procedures;
- e) include charts or diagrams if they will help to explain the terms of the agreement.

1.10.5 The format for letters of agreement should take account of the following points:

- a) Parties to the agreement: Specify the agencies, units, authorities between which the letter is agreed;
- b) Subject: Define the subject of the agreement;

1.10.6 The format for operations letters may vary due to the variety of subjects which can be covered; therefore, no specific format can be prescribed; however, the provisions for letters of agreement as shown in 1.10.5 above should be used whenever this is possible.

1.11 FACILITY SECURITY

1.11.1 In view of their importance to the safety and efficiency of air navigation, ATS facilities on or off the aerodrome need to be protected in order to ensure their unimpeded operation. However, because these facilities are part of a co-operative system jointly exploited by providers and users, it is important that they be readily accessible to those having a legitimate requirement for entry, be this for familiarization or for the exchange of essential information between ATS staff on duty, flight crews and/or other representatives of operators.

1.11.2 In the assessment of the threat by the competent authority of the State, it is essential that ATS management be involved in the consultative process in order to assist in the formulation of the security measures and procedures which are to be adopted and thereby ensuring that they will be compatible with the operating requirements of the ATS.

1.11.3 General air-side security arrangements for aerodromes is provided in Doc 9184, *Airport Planning Manual*. More detailed information on security in aviation is contained in ICAO Doc 8973, *Security Manual for Safeguarding Civil Aviation Against Acts of Unlawful Interference*.

1.11.4 As a basic concept, it must be recognized that provision for security systems, devices and requirements in the planning of a new ATS facility is economical and

provides for maximum operating efficiency. Security requirements for new ATS facilities should therefore be examined and established by competent security expertise at the earliest feasible planning stages.

1.11.5 Although the installation of closed-circuit television systems and other communications and electronic security devices may not be an immediate requirement, consideration should be given to the provision of ducts and cable runs in the construction of new buildings, so as to permit easy and effective installation of security devices and systems when justified by changing circumstances.

1.11.6 In the planning of specific security measures for a given unit, every endeavour should be made to minimize the involvement of ATS personnel. Security arrangements cannot take priority over operational safety considerations. Distractions from duty to operate security devices and access controls should therefore be avoided. The noise level of security equipment alarms and the possible confusion with ATS equipment signals must be carefully considered before such alarms are located in ATS operational areas.

1.12 PERSONNEL SECURITY

1.12.1 All persons working in an ATS restricted area should be required to display an approved identification card on their outer garment at all times while in such areas.

1.12.2 All personnel should be thoroughly familiar with the security arrangements for their unit. Lectures on security should be part of on-going training and refresher courses. An essential element in that training is the encouragement of ATS staff to courteously question each person seen in ATS restricted areas who is not on duty or who is not an escorted or authorized visitor.

1.13 ARRANGEMENTS FOR VISITORS

1.13.1 As a general policy, only those persons whose duties require them to enter ATS units should be admitted to restricted areas. Such persons may include, apart from staff on duty, pilots of aircraft and aerodrome and operational staff such as meteorological officers, technicians and groundsmen in the performance of their duties.

1.13.2 Entry into ATS units by other than essential duty personnel should only be permitted if their presence will not distract those on duty during busy or emergency circumstances.

1.13.3 Visitors should normally only be admitted after a proper authorization to do so has been obtained. In order to meet the desirable objective of frequent contacts between ATS and other interested parties (e.g. foreign visitors, persons from industry, students, etc.) the procedures to obtain such authorization should be administratively as simple as compliance with security requirements allow.

— — — — —

Appendix A

General Guide to Good Management Practices

1. Know the public service and departmental organization and ensure your staff is fully informed.
 2. Know your station and endeavour to become fully familiar with all aspects of its operation.
 3. Be loyal to your staff as well as to your service.
 4. Foster co-operation within your unit.
 5. Ensure that all supervisory or senior staff accept responsibility. Use a check list to measure work to be done and your efforts and progress.
 6. Delegate responsibility and authority, particularly at the higher levels of supervision.
 7. Monitor workloads closely. Remember that workloads directly affect safety as well as economy.
 8. Ensure that a supervisory officer sits in parallel with every watchkeeping officer for at least one hour per week to point out weaknesses, and more importantly, to point the way to and encourage correction.
 9. Intensify supervision of watchkeeping shifts when out-of-the ordinary operating conditions exist, such as marginal weather conditions, failure of radio aids, or when special missions take place.
 10. Do not oppose change. Give a new procedure adequate trial before criticizing it.
 11. Make criticism of operating practices constructive. Suggest an alternative practice or give reasons for the cancellation of the present practice.
 12. Acknowledge that if a standard practice or procedure is worth changing at one particular location, then probably the improvements which result may also apply throughout the ATS organization on a wider scale; refer new ideas through channels to headquarters in order that wherever justified, the standard or practice as a whole may be changed.
 13. Complete routine tasks daily. Do not allow them to accumulate with consequent possibility of errors or omissions.
 14. Respond to papers referred to you and require your staff to do the same. Do not put them aside and later express surprise that required action has not been taken.
 15. Check to see that all unit correspondence is properly and quickly answered, and that publications are properly amended.
 16. Do not issue a multitude of information in a multitude of ways; issue information in a comprehensive way and then ensure that what is to be done is being done.
 17. Check that the latest amendments are understood by all concerned and in good time before implementation. Amendments often require quite extensive study and explanation; these studies should be organized.
 18. Keep close surveillance on working conditions. The ultimate in good working conditions may involve major building alterations or even new buildings, but meanwhile much can be done by the straightforward approach of good housekeeping in making the best of what is available.
 19. Be mindful of staff welfare. Prepare the way for the newcomer and, as appropriate, his family. Ensure your unit's support preparations and amenities are adequate.
 20. In checking an officer, be objective.
 21. Be aware of your reporting channels and those available to your staff.
 22. Avoid giving grounds for the following frequently voiced staff grievances:
 - a) issuing orders without giving the underlying reasons;
 - b) evasive answers to direct questions;
 - c) reprimanding staff in the presence of others;
 - d) blaming staff unfairly;
 - e) withholding credit when due and taking credit for others' ideas;
 - f) ignoring or discouraging suggestions;
 - g) breaking promises;
 - h) ignoring complaints;
 - i) poor working conditions;
 - j) poor planning of duty rosters;
 - k) poor instructions that lead to mistakes;
 - l) unfair handling of overtime;
 - m) favouritism or semblance of favouritism;
 - n) ill-prepared rating or proficiency assessments;
 - o) obstructing staff opportunities.
 23. Accept supervisory visits as they come. For those visits of which you are advised in advance, prepare a brief list of points you would like to see discussed.
-

Appendix B

Job Descriptions of Posts in ATS

1. The duties and responsibilities of the **Chief Regional ATS Office** should include:
 - a) ensuring the prompt application of all applicable air traffic regulations and instructions and the implementation of ATC directives issued by Headquarters;
 - b) bi-annual inspections of all ATS units to ensure their efficiency;
 - c) visits, as required, to other Regional Offices to ensure interregional co-ordination;
 - d) close liaison with operators and flying clubs on ATS matters;
 - e) close liaison with the military and allied forces operating in the region;
 - f) the review and follow-up of air traffic incidents;
 - g) formulating recommendations on ATC procedures and facilities to meet changing conditions and improve the co-ordination of procedures between civil operators and the military;
 - h) reviewing the working methods and organization of the ATS units in the region to ensure efficient and economical operation and submitting recommendations for revision of personnel requirements as appropriate;
 - i) issuing and/or validating licences and ratings when appropriate;
 - j) approve ATS orders and instructions to the field;
 - k) authorizing the requirement for and providing personnel and facilities for air shows, flying displays and special flying operations at locations where ATS is not permanently provided.
2. The duties and responsibilities of a **Chief of ACC**, should include:
 - a) responsibility for the provision of ATS within the airspace for which the unit is responsible in accordance with the procedures and practices prescribed in relevant documents;
 - b) ensuring that the ACC operates efficiently and is administered in accordance with relevant provisions;
 - c) directing the work of ATC and other personnel under his control and interpreting regulations so as to ensure conformity with ATC procedures;
 - d) arranging for the training of ATC personnel for the issuance and validation of ratings;
 - e) investigating reports of non-compliance with regulations and procedures;
 - f) maintaining close liaison with local operators and other user interests and providing all possible assistance to flight crew in familiarizing them with ATC procedures;
 - g) ensuring that all necessary technical equipment, publications and facilities are available and properly maintained;
3. The duties and responsibilities of the **Chief of Aerodrome Control Tower** should include:
 - a) that his aerodrome control tower operates efficiently and is administered in accordance with relevant provisions;
 - b) directing the work of ATC and other personnel under his control and interpreting regulations so as to ensure conformity with ATC procedures;
 - c) supervising the training of control personnel and making recommendations for the issue and validation of ratings;
 - d) investigating reports of non-compliance with regulations and procedures and forwarding the result of such investigations to the Chief, ATS Region or, in the case of minor breaches, taking the necessary action himself;
 - e) maintaining close liaison with local operators and interested organizations and providing all possible assistance to flight crew in familiarizing them with ATC procedures and other operational procedures and regulations;
 - f) ensuring that all necessary technical equipment, publications and facilities are available and properly maintained;
 - g) participation in rating and validation examinations;

- h) preparation and issuance of unit orders and local knowledge questionnaires for use in rating and validation examinations;
- i) maintaining records and submitting reports on personnel, traffic activity and all phases of ATC operations as required by the department;
- j) standing a watch in each operating position often enough to maintain proficiency for the ratings held.

4. Where the position of deputy unit chief is established in an ACC or aerodrome control tower, he may be required to assume responsibility for any or all of the items b) to i) above.

5. The duties and responsibilities of a **Unit Evaluation and Proficiency Development Officer** should include:

- a) supervising and arranging the training programme for unit personnel;
- b) checking on the progress of personnel undergoing training and submitting training reports as required;
- c) completing rating and validation assessments on personnel as required;
- d) attending rating and validation examinations as required;
- e) assisting in the preparation of local knowledge questionnaires for use in rating and validation examinations;
- f) training controllers in new procedures and operating techniques;
- g) ensuring that the approved methods and procedures are practised within the unit and where necessary making recommendations to improve these procedures;
- h) standing a watch in each operating position for a sufficient number of occasions to maintain proficiency for the ratings held;
- i) maintaining such records as are necessary for the efficient execution of his duties.

6. During a tour of duty a **Watch Supervisor** in any ATS unit should be responsible for:

- a) directing and co-ordinating the control of air traffic within the airspace for which the unit is responsible;
- b) the disposition of the personnel on duty and the adjustment of the functions of operating positions so as to meet the traffic demand in a satisfactory manner;
- c) ensuring that operating positions are occupied by qualified personnel who are in current operating practice and ensuring that staff are kept operationally proficient;
- d) maintaining the ATS log and ensuring that all relevant details are recorded;
- e) carrying out frequent checks on the data displays, communications channels and messages originated in

the unit and drawing the attention of personnel concerned to any errors, omissions, irregularities or the use of non-standard procedures;

- f) initiating, when necessary in collaboration with other ATC units and authorities, alerting service action in accordance with prescribed procedures;
- g) performing such administrative duties as may be directed by the unit chief;
- h) reporting to the unit chief, through the deputy chief, if applicable, on:
 - 1) all phases of ATC operations requiring the unit chief's attention;
 - 2) changes in serviceability of navigational and ATC equipment and facilities;
 - 3) non-compliance with regulations and procedures;
 - 4) complaints or incidents involving the ATC service;
 - 5) any other matters of general operational interest;
- i) recommending to the unit chief, through the deputy, if applicable, improvements to procedures and operating methods;
- j) ensuring that staff under training are fully occupied either by on-the-job training, study or related activity;
- k) standing a watch in each operating position often enough to maintain proficiency for all ratings held.

7. An **Air Traffic Controller** is responsible to his supervisor for:

- a) the control of air traffic within that airspace for which he is responsible. In addition, an aerodrome controller is responsible for maintaining, as far as practicable, a continuous watch on all visible operations on and in the vicinity of the aerodrome, including aircraft, vehicles and personnel on the manoeuvring area and carrying out airfield and facility inspections. A radar controller is responsible for the provision of radar service within the service area for which he is responsible, including the provision of radar monitored approaches in accordance with prescribed procedures and practices and for the setting up, checking and operation of the radar in accordance with the prescribed instructions;
- b) remaining in the control room during the period of watch unless properly relieved;
- c) rendering all possible assistance to aircraft in emergency or distress;
- d) providing aircraft with meteorological and other information required for the safe and efficient conduct of their flight;
- e) maintaining a continuous watch on the assigned communication channels;
- f) maintaining, in the approved manner, a flight progress display of all aircraft for which he is responsible;
- g) relaying serviceability reports and navigational warnings as required;

-
- h) complying with procedures detailed in unit operating instructions including those pertaining to:
 - 1) opening and closing operating positions;
 - 2) taking over an operating position;
 - 3) unserviceable equipment and facilities;
 - i) performing such other duties relative to ATC operations as may be assigned to him by his unit chief or watch supervisor.
-

Chapter 2

Co-ordination

2.1 INTRODUCTION

2.1.1 Co-ordination is the act of negotiation between two or more parties, each vested with the authority to make decisions appropriate to the matter being discussed, and where normally a common course of action, based on known information, is agreed upon. Co-ordination between air traffic services (ATS) units concerned is essential for all flights within controlled airspace. The ATS co-ordination is often accomplished prior to the time such co-ordination is actually required.

2.1.2 Co-ordination may be achieved by direct negotiation and agreement between air traffic control (ATC) personnel for individual flights, agreements made between ATC units in accordance with unit instructions, or by use of permanent procedures agreed between national aviation authorities. Additionally, co-ordination is deemed to have been effected if an estimate message has been received by the accepting ATS unit and no objection has been raised.

2.1.3 Further to the relevant provisions in Annex 11, the following aspects of co-ordination should be noted. Individual ATS units are part of an ATS system and therefore any unit having noted errors should bring these apparent errors or omissions to the attention of the originating unit. In so doing, care must be taken to ensure, on the one hand, that there is real cause for such action and, on the other hand, that this is done in a spirit of co-operation rather than one of criticism. Any significant shortcoming or difference of opinion, particularly where interregional activity is involved, should be brought to the attention of the supervisor, to allow him to check the interpretation or ruling which was agreed or disagreed at the lower level.

2.2 CO-ORDINATION WITH OPERATORS, AIRMEN AND OTHERS

2.2.1 Co-ordination between the ATS and the military, adjoining States, civil agencies, and other aviation

organizations is discussed in Part II, Section 1, Chapter 2. The ATS unit chief controller has the responsibility to maintain regular contact with the airspace users, to listen to their suggestions and complaints and to co-ordinate operations and endeavour to resolve differences that may occur.

2.2.2 It is the usual practice for pilots and operators to form interest groups so that any interventions made by them have the support of a group as a whole, rather than expressions of individual needs. Such groups normally include air transport operators' associations, aircraft owners' and pilots' associations, general commercial aviation associations, air line pilots' associations, and flight training schools. A unit chief controller should be prepared to meet with representatives of each or all of these groups from time to time with the object of discussing new procedures, resolving operational problems between groups and generally contributing to the maintenance of good will between all parties involved in aviation.

2.2.3 Special consideration may have to be given to environmental factors. Noise abatement is usually the most controversial as it can involve the introduction of flight procedures resulting in an increase in cockpit workload. The unit chief controller may, in these circumstances, be required to participate in negotiations with local community associations.

2.2.4 Flight training schools and local flying clubs resident on an aerodrome frequently require special procedures to enable them to safely mix with commercial aviation. Such conditions may involve allocating discrete operating areas both on the aerodrome and in the adjacent airspace. Helicopter operations may also need special consideration for similar reasons, but with differing procedural and operating space requirements.

2.2.5 Unit chief controllers should arrange regular meetings with all other technical and operational groups associated with the smooth functioning of the unit. This includes the chiefs of communications, technical

maintenance, aerodrome maintenance, electrical and mechanical maintenance, fire and rescue services and aerodrome management. It is essential to plan regular meetings, well in advance, and to maintain an accurate and

readily available record of discussions and decisions. A unit chief controller should not hesitate to request regional assistance in the event that a problem cannot be resolved and/or co-ordinated at the level of the unit.

AIR TRAFFIC SERVICES PLANNING MANUAL

PART V

TERMS AND REFERENCES

AIR TRAFFIC SERVICES PLANNING MANUAL

PART V

SECTION 1. TERMS AND ABBREVIATIONS

SECTION 1
TERMS AND ABBREVIATIONS

Contents

	<i>Page</i>
Chapter 1. Glossary of Terms.....	V-1-1-1
1.1 Introduction.....	V-1-1-1
1.2 Air traffic service terms	V-1-1-1
Chapter 2. Commonly Used Abbreviations	V-1-2-1
2.1 Introduction.....	V-1-2-1
2.2 Abbreviations	V-1-2-1

Chapter 1

Glossary of Terms

1.1 INTRODUCTION

Terms which are defined in the *ICAO Lexicon* (Doc 9294) and the Standards and Recommended Practices (SARPs) and Procedures for Air Navigation Services (PANS) are used in accordance with the meanings and usages given therein. However, there still remains a wide variety of terms throughout the world used to describe facilities, services, procedures and concepts for planning air traffic services (ATS). As far as possible, the terms used in this document, and defined below, are those which have the widest international use.

1.2 AIR TRAFFIC SERVICE TERMS

When the following terms are used in this manual, they have the following meanings:

Accepting unit/controller. Air traffic control unit/air traffic controller next to take control of an aircraft.

Note.— See definition of *Transferring unit/controller*.

Acknowledgement. Notification that a given communication has been correctly received and understood.

Acrobatic flight. Manoeuvres intentionally performed by an aircraft involving an abrupt change in its attitude, an abnormal attitude, or an abnormal variation in speed.

Advisory airspace. A generic term meaning variously, advisory area(s) or advisory route(s).

Advisory area. A designated area within a flight information region where air traffic advisory service is available.

Advisory route. A route within a flight information region along which air traffic advisory service is available.

Note.— *Air traffic control service provides a much more complete service than air traffic advisory service; advisory areas and routes are therefore not established within controlled airspace, but air traffic advisory service may be provided below and above control areas.*

Aerodrome. A defined area on land or water (including any buildings, installations and equipment) intended to be used either wholly or in part for the arrival, departure and surface movement of aircraft.

Aerodrome control service. Air traffic control service for aerodrome traffic.

Aerodrome control tower. A unit established to provide air traffic control service to aerodrome traffic.

Aerodrome elevation. The elevation of the highest point of the landing area.

Aerodrome taxi circuit. The specified path of aircraft on the manoeuvring area during specific wind conditions.

Aerodrome traffic. All traffic on the manoeuvring area of an aerodrome and all aircraft flying in the vicinity of an aerodrome.

Note.— *An aircraft is in the vicinity of an aerodrome when it is in, entering or leaving an aerodrome traffic circuit.*

Aerodrome traffic circuit. The specified path to be flown by aircraft operating in the vicinity of an aerodrome.

Aerodrome traffic zone. An airspace of defined dimensions established around an aerodrome for the protection of aerodrome traffic.

- Aeronautical fixed service (AFS).** A telecommunication service between specified fixed points provided primarily for the safety of air navigation and for the regular, efficient and economical operation of air services.
- Aeronautical fixed station.** A station in the aeronautical fixed service.
- Aeronautical ground light.** Any light specially provided as an aid to air navigation, other than a light displayed on an aircraft.
- Aeronautical information publication.** A publication issued by or with the authority of a State and containing aeronautical information of a lasting character essential to air navigation.
- Aeronautical mobile service.** A radiocommunication service between aircraft stations and aeronautical stations, or between aircraft stations.
- Aeronautical station.** A land station in the aeronautical mobile service carrying on a service with aircraft stations. In certain instances, an aeronautical station may be placed on board a ship or an earth satellite.
- Aeronautical telecommunication service.** A telecommunication service provided for any aeronautical purpose.
- Aeronautical telecommunication station.** A station in the aeronautical telecommunication service.
- Aeroplane.** A power-driven heavier-than-air aircraft, deriving its lift in flight chiefly from aerodynamic reactions on surfaces which remain fixed under given conditions of flight.
- AFIL.** An alpha character group used to designate an air-filed flight plan.
- Agreed reporting point.** A point specified in the route description of a flight plan and agreed between the operator and the air traffic services unit to serve as a reporting point for the flight concerned.
- Aircraft.** Any machine that can derive support in the atmosphere from the reactions of the air other than the reactions of the air against the earth's surface.
- Aircraft call sign.** A group of alphanumeric characters used to identify an aircraft in air-ground communication.
- Aircraft identification.** A group of letters, figures or a combination thereof which is either identical to, or the coded equivalent of, the aircraft call sign to be used in air-ground communications, and which is used to identify the aircraft in ground-ground air traffic services communications.
- Aircraft observation.** The evaluation of one or more meteorological elements made from an aircraft in flight.
- Aircraft type designator.** A group of alphanumeric characters used to identify, in an abbreviated form, a type of aircraft.
- Air-filed flight plan (AFIL).** A flight plan provided to an air traffic services unit by an aircraft during its flight.
- Air-ground communication.** Two-way communication between aircraft and stations or locations on the surface of the earth.
- Air-ground control radio station.** An aeronautical telecommunication station having primary responsibility for handling communications pertaining to the operation and control of aircraft in a given area.
- Air-report.** A report from an aircraft in flight prepared in conformity with requirements for position and operational and/or meteorological reporting.
- Air route facilities.** Facilities provided to permit safe operation of aircraft along an air route, including visual and radio navigation aids for approach and landing at aerodromes, and communication services, meteorological services and air traffic services and facilities.
- Airspace reservation.** A defined volume of airspace normally under the jurisdiction of one aviation authority and temporarily reserved, by common agreement, for exclusive use by another aviation authority.
- Airspace volume concept.** A concept of controlled airspace organization which allows an aircraft operator complete freedom to manoeuvre within a designated airspace.
- Air-to-ground communication.** One-way communication from aircraft to stations or locations on the surface of the earth.
- Air traffic.** All aircraft in flight or operating on the manoeuvring area of an aerodrome.
- Air traffic advisory service.** A service provided within advisory airspace to ensure separation, in so far as

possible, between aircraft which are operating on IFR flight plans.

Air traffic control clearance. Authorization for an aircraft to proceed under conditions specified by an air traffic control unit.

Note 1.— For convenience, the term air traffic control clearance is frequently abbreviated to clearance when used in appropriate contexts.

Note 2.— The abbreviated term clearance may be prefixed by the words taxi, take-off, departure, en route, approach or landing to indicate the particular portion of flight to which the air traffic control clearance relates.

Air traffic control service. A service provided for the purpose of:

- 1) preventing collisions
 - a) between aircraft;
 - b) on the manoeuvring area between aircraft and obstructions; and
- 2) expediting and maintaining an orderly flow of air traffic.

Air traffic control unit. A generic term meaning variously, area control centre, approach control office or aerodrome control tower.

Air traffic service. A generic term meaning variously, flight information service, alerting service, air traffic advisory service, air traffic control service, area control service, approach control service or aerodrome control service.

Air traffic services reporting office. A unit established for the purpose of receiving reports concerning air traffic services and flight plans submitted before departure.

Note.— An air traffic services reporting office may be established as a separate unit or combined with an existing unit, such as another air traffic services unit or a unit of the aeronautical information service.

Air traffic services unit. A generic term meaning variously, air traffic control unit, flight information centre or air traffic services reporting office.

Airway. A control area or portion thereof established in the form of a corridor equipped with radio navigational aids.

ALERFA. The code word used to designate an alert phase.

Alerting service. A service provided to notify appropriate organizations regarding aircraft in need of search and rescue aid, and assist such organizations as required.

Alert phase. A situation wherein apprehension exists as to the safety of an aircraft and its occupants.

Alphanumeric characters (alphanumerics). A collective term for letters and figures (digits).

Alphanumeric display. A presentation of letters and figures either on a radar display or on a separate screen or panel.

Alternate aerodrome. An aerodrome specified in the flight plan to which a flight may proceed when it becomes inadvisable to land at the aerodrome of intended landing.

Note.— An alternate aerodrome may be the aerodrome of departure.

Altitude. The vertical distance of a level, a point or an object considered as a point, measured from mean sea level (MSL).

Approach control office. A unit established to provide air traffic control service to controlled flights arriving at, or departing from, one or more aerodromes.

Approach control service. Air traffic control service for arriving or departing controlled flights.

Approach funnel. A specified airspace around a nominal approach path within which an aircraft approaching to land is considered to be making a normal approach.

Approach sequence. The order in which two or more aircraft are cleared to approach to land at the aerodrome.

Appropriate ATS authority. The relevant authority designated by the State responsible for providing air traffic services in the airspace concerned.

Appropriate authority.

- 1) Regarding flight over the high seas: The relevant authority of the State of Registry.
- 2) Regarding flight other than over the high seas: The relevant authority of the State having sovereignty over the territory being overflown.

Apron. A defined area, on a land aerodrome, intended to accommodate aircraft for purposes of loading or

unloading passengers, mail or cargo, refuelling, parking or maintenance.

Apron management service. A service provided to regulate the activities and movement of aircraft and vehicles on an apron.

Area control centre. A unit established to provide air traffic control service to controlled flights in control areas under its jurisdiction.

Area control service. Air traffic control service for controlled flights in control areas.

Area navigation (RNAV). A method of navigation which permits aircraft operation on any desired flight path within the coverage of station-referenced navigation aids or within the limits of the capability of self-contained aids, or a combination of these.

Area navigation route. An ATS route established for the use of aircraft capable of employing area navigation.

Assignment, assign. Distribution (of frequencies) to stations. Distribution (of SSR codes) to aircraft.

ATC loop. An ordered cycle of information or data flow, computation, co-ordination, decision making, control and monitoring, which constitutes the complete function of an air traffic control unit.

ATIS. The symbol used to designate automatic terminal information service.

ATS airspace. Collective term for airspace within which one or more air traffic services are provided to aircraft.

ATS route. A specified route designed for channelling the flow of traffic as necessary for the provision of air traffic services.

Note.— The term ATS route is used to mean variously, airway, advisory route, controlled or uncontrolled route, arrival or departure route, etc.

Automatic terminal information service. The provision of current, routine information to arriving and departing aircraft by means of continuous and repetitive broadcasts throughout the day or a specified portion of the day.

Base turn. A turn executed by the aircraft during the initial approach between the end of the outbound track and

the beginning of the intermediate or final approach track. The tracks are not reciprocal.

Note.— Base turns may be designated as being made either in level flight or while descending, according to the circumstances of each individual procedure.

Blind transmission. A transmission from one station to another station in circumstances where two-way communication cannot be established but where it is believed that the called station is able to receive the transmission.

Blind velocity. The radial velocity of a moving target such that the target is not seen on primary radars fitted with certain forms of fixed echo suppression.

Bright display. A radar display capable of being used under relatively high ambient light levels.

Broadcast. A transmission of information relating to air navigation that is not addressed to a specific station or stations.

Ceiling. The height above the ground or water of the base of the lowest layer of cloud below 6 000 m (20 000 ft) covering more than half the sky.

Clearance function. The formulation and transmission of a clearance by an air traffic control unit as well as the acknowledgement and acceptance of such clearance by the pilot.

Clearance limit. The point to which an aircraft is granted an air traffic control clearance.

Clearance void time. A time specified by an air traffic control unit at which a clearance ceases to be valid unless the aircraft concerned has already taken action to comply therewith.

Code (SSR Code). The number assigned to a particular multiple pulse reply signal transmitted by a transponder.

Computer. A device which performs sequences of arithmetical and logical steps upon data without human intervention.

Note.— When the word computer is used in this document it may denote a computer complex, which includes one or more computers and peripheral equipment.

Conference communications. Communication facilities whereby direct-speech conversation may be conducted between three or more locations simultaneously.

Conflict. Predicted converging of aircraft in space and time which constitutes a violation of a given set of separation minima.

Conflict detection. The discovery of a conflict as a result of a conflict search.

Conflict resolution. The determination of alternative flight paths which would be free from conflicts and the selection of one of these flight paths for use.

Conflict search. Computation and comparison of the predicted flight paths of two or more aircraft for the purpose of determining conflicts.

Contact point. A specified position, time or level at which an aircraft is required to establish radiocommunication with an air traffic control unit.

Control area. A controlled airspace extending upwards from a specified limit above the earth.

Control assistant. A person who assists in the provision of air traffic services but who is not authorized to make decisions regarding clearances, advice or information to be issued to aircraft.

Controlled aerodrome. An aerodrome at which air traffic control service is provided to aerodrome traffic.

Note.— The term controlled aerodrome indicates that air traffic control service is provided to aerodrome traffic but does not necessarily imply that a control zone exists, since a control zone is required at aerodromes where air traffic control service will be provided to IFR flights, but not at aerodromes where it will be provided only to VFR flights.

Controlled airspace. An airspace of defined dimensions within which air traffic control service is provided to controlled flights.

Controlled airspace (instrument restricted). Controlled airspace within which only IFR flights are permitted.

Controlled airspace (instrument/visual). Controlled airspace within which only IFR and controlled VFR flights are permitted.

Controlled airspace (visual exempted). Controlled airspace within which both IFR and VFR flights are permitted, but VFR flights are not subject to control.

Controlled flight. Any flight which is provided with air traffic control service.

Controlled VFR flight. A controlled flight conducted in accordance with the visual flight rules.

Controller. A person authorized to provide air traffic control services.

Control sector. A subdivision of a designated control area within which responsibility is assigned to one controller or to a small group of controllers.

Control zone. A controlled airspace extending upwards from the surface of the earth to a specified upper limit.

Co-ordination. The process of obtaining agreement on clearances, transfer of control, advice or information to be issued to aircraft, by means of information exchanged between air traffic services units or between controller positions within such units.

Cruise climb. An aeroplane cruising technique resulting in a net increase in altitude as the aeroplane weight decreases.

Cruising level. A level maintained during a significant portion of a flight.

Current flight plan. The flight plan, including changes if any, brought about by subsequent clearances.

Note.— When the word message is used as a suffix to this term, it denotes the content and format of the current flight plan data sent from one unit to another.

Danger area. An airspace of defined dimensions within which activities dangerous to the flight of aircraft may exist at specified times.

Data convention. An agreed set of rules governing the manner or sequence in which a set of data may be combined into a meaningful communication.

Data processing. A systematic sequence of operations performed on data.

Note.— Examples of operations are the merging, sorting, computing or any other transformation or rearrangement with the object of extracting or revising

information, or of altering the representation of information.

Decision altitude/height (DA/H). A specified altitude or height (A/H) in the precision approach at which a missed approach must be initiated if the required visual reference to continue the approach has not been established.

Note 1.— Decision altitude (DA) is referenced to mean sea level (MSL) and decision height (DH) is referenced to the threshold elevation.

Note 2.— The required visual reference means that section of the visual aids or of the approach area which should have been in view for sufficient time for the pilot to have made an assessment of the aircraft position and rate of change of position, in relation to the nominal flight path.

Decoder (or ground decoder, or ground decoding equipment). The device used to decipher replies received from transponders.

Departure point. Aerodrome or point in space from which departure takes place.

DETRESFA. The code word used to designate a distress phase.

Display. A visual presentation of data in a manner which permits interpretation by a controller.

Distress phase. A situation wherein there is reasonable certainty that an aircraft and its occupants are threatened by grave and imminent danger or require immediate assistance.

Diversion. The act of proceeding to an aerodrome other than one at which a landing was intended.

Elevation. The vertical distance of a point or a level, on or affixed to the surface of the earth, measured from mean sea level.

Emergency phase. A generic term meaning, as the case may be, uncertainty phase, alert phase or distress phase.

En-route clearance. A clearance covering the flight path of an aircraft after take-off to the point at which an approach to land is expected to commence.

Note.— In some circumstances it may be necessary to subdivide this clearance, e.g. into sections divided by

control area boundaries or into the departure, climb, or descent phases of flight.

Entry fix. The first reporting point, determined by reference to a navigation aid, over which an aircraft passes or is expected to pass upon entering a flight information region or a control area.

Estimated time of arrival. For IFR flights, the time at which it is estimated that the aircraft will arrive over that designated point, defined by reference to navigation aids, from which it is intended that an instrument approach procedure will be commenced, or, if no navigation aid is associated with the aerodrome, the time at which the aircraft will arrive over the aerodrome. For VFR flights, the time at which it is estimated that the aircraft will arrive over the aerodrome.

Expected approach time. The time at which ATC expects that an arriving aircraft, following a delay, will leave the holding point to complete its approach for a landing.

Note.— The actual time of leaving the holding point will depend upon the approach clearance.

Exit fix. The last reporting point, determined by reference to a navigation aid, over which an aircraft passes or is expected to pass before leaving a flight information region or a control area.

Filed flight plan. The flight plan as filed with an ATS unit by the pilot or his designated representative, without any subsequent changes.

Note.— When the word "message" is used as a suffix to this term, it denotes the content and format of the filed flight plan data as transmitted.

Final approach. That part of an instrument approach procedure which commences at the specified final approach fix or point, or where such a fix or point is not specified:

- a) at the end of the last procedure turn, base turn or inbound turn of a racetrack procedure, if specified; or
- b) at the point of interception of the last track specified in the approach procedure; and

ends at a points in the vicinity of an aerodrome from which:

- 1) a landing can be made; or
- 2) a missed approach procedure is initiated.

Flight crew member. A licensed crew member charged with duties essential to the operation of an aircraft during flight time.

Flight data. Data regarding the actual or intended movement of aircraft, normally presented in coded or abbreviated form.

Flight information. Information useful for the safe and efficient conduct of flight, including information on air traffic, meteorological conditions, aerodrome conditions or air route facilities.

Flight information centre. A unit established to provide flight information service and alerting service.

Flight information region. An airspace of defined dimensions within which flight information service and alerting service are provided.

Flight information service. A service provided for the purpose of giving advice and information useful for the safe and efficient conduct of flights.

Flight level. A surface of constant atmospheric pressure which is related to a specific pressure datum, 1013.2 hPa (1013.2 mb), and is separated from other such surfaces by specific pressure intervals.

Note 1.— A pressure type altimeter calibrated in accordance with the standard atmosphere:

- a) when set to a QNH altimeter setting, will indicate altitude;
- b) when set to QFE altimeter setting, will indicate height above the QFE reference datum;
- c) when set to a pressure of 1013.2 hPa (1013.2 mb) may be used to indicate flight levels.

Note 2.— The terms height and altitude, used in Note 1 above, indicate altimetric rather than geometric heights and altitudes.

Flight plan. Specified information provided to air traffic services units, relative to an intended flight or portion of a flight of an aircraft.

Note.— Specifications for flight plans are contained in Annex 2. A model flight plan form is contained in Appendix 2 to this document.

Flight plan data. Data selected from the flight plan for purposes of processing, display or transfer.

Flight progress board. A board designed and used for the tabular display of flight data.

Flight progress display. A display of data from which the actual and intended progress of flights may be readily determined.

Flight progress strip. Strip used for the display of flight data on a flight progress board.

Flight status. An indication of whether a given aircraft requires special handling by air traffic services units or not.

Flight visibility. The visibility forward from the cockpit of an aircraft in flight.

Flow control. Measures designed to adjust the flow of traffic into a given airspace, along a given route, or bound for a given aerodrome, so as to ensure the most effective utilization of the airspace.

Forecast. A statement of expected meteorological conditions for a specified time or period, and for a specified area or portion of airspace.

Garbling. The degradation of code information due to the simultaneous presence in a decoder of overlapping reply pulse trains.

Glide path. A descent profile determined for vertical guidance during a final approach.

Ground speed. The speed of an aircraft relative to the surface of the earth.

Ground-to-air communication. One-way communication from stations or locations on the surface of the earth to aircraft.

Ground visibility. The visibility at an aerodrome, as reported by an accredited observer.

Heading. The direction in which the longitudinal axis of an aircraft is pointed, usually expressed in degrees from North (true, magnetic, compass or grid).

Height. The vertical distance of a level, a point or an object considered as a point, measured from a specified datum.

Holding point. A specified location, identified by visual or other means, in the vicinity of which the position of an

aircraft in flight is maintained in accordance with air traffic control clearances.

Holding procedure. A predetermined manoeuvre which keeps an aircraft within a specified airspace whilst awaiting further clearance.

IFR. The symbol used to designate the instrument flight rules.

IFR flight. A flight conducted in accordance with the instrument flight rules.

IMC. The symbol used to designate instrument meteorological conditions.

INCERFA. The code word used to designate an uncertainty phase.

Indicated airspeed. The uncorrected reading on the airspeed indicator.

Initial approach. That part of an instrument approach procedure consisting of the first approach to the first navigational facility associated with the procedure, or to a predetermined fix.

Initial approach segment. That segment of an instrument approach procedure between the initial approach fix and the intermediate approach fix or, where applicable, the final approach fix or point.

Instrument approach procedure. A series of predetermined manoeuvres by reference to flight instruments with specified protection from obstacles from the initial approach fix or, where applicable, from the beginning of a defined arrival route, to a point from which a landing can be completed and thereafter, if a landing is not completed, to a position at which holding or en-route obstacle clearance criteria apply.

Instrument flight rules. A set of rules governing the conduct of flight under instrument meteorological conditions.

Instrument meteorological conditions. Meteorological conditions expressed in terms of visibility, distance from cloud, and ceiling, less than the minima specified for visual meteorological conditions.

Note 1.— The specified minima for visual meteorological conditions are contained in Chapter 4 of Annex 2.

Note 2.— In a control zone, a VFR flight may proceed under instrument meteorological conditions if and as authorized by air traffic control.

International NOTAM Office. An office designated by a State for the exchange of NOTAM internationally.

Joining point. The point at which an aircraft enters or is expected to enter a control area from uncontrolled airspace.

Landing area. That part of a movement area intended for the landing or take-off of aircraft.

Lateral separation. Separation between aircraft expressed in terms of distance or angular displacement between tracks.

Leaving point. The point at which an aircraft leaves or is expected to leave a control area for uncontrolled airspace.

Level. A generic term relating to the vertical position of an aircraft in flight and meaning variously, height, altitude or flight level.

Limited route concept. A concept of controlled airspace organization which requires an aircraft operator to choose between a limited number of specified ATS routes for a flight from one point to another.

Location indicator. A four-letter code group formulated in accordance with rules prescribed by ICAO and assigned to the location of an aeronautical fixed station.

Longitudinal separation. Separation between aircraft expressed in units of time or distance along track.

Manoeuvring area. That part of an aerodrome to be used for the take-off, landing and taxiing of aircraft, excluding aprons.

Message. A communication sent from one location to another and comprising an integral number of fields.

Message element. The smallest assembly of characters, in a message, which has an independent meaning.

Note.— A message element is analogous to a word in plain language.

Message field. An assigned area of a message containing specified elements of data.

Message format. The disposition and structure of the message fields which constitute a message.

Meteorological information. Meteorological report, analysis, forecast, and any other statement relating to existing or expected meteorological conditions.

Meteorological office. An office designated to provide meteorological service for international air navigation.

Meteorological report. A statement of observed meteorological conditions related to a specified time and location.

Missed approach procedure. The procedure to be followed if the approach cannot be continued.

Mode (SSR Mode). The letter or number assigned to a specific pulse spacing of the interrogation signals transmitted by an interrogator. There are 4 modes, A, B, C and D specified in Annex 10, corresponding to four different interrogation pulse spacings.

Movement area. That part of an aerodrome to be used for the take-off, landing and taxiing of aircraft consisting of the manoeuvring area and the apron(s).

Non-radar separation. The separation used when aircraft position information is derived from sources other than radar.

NOTAM. A notice containing information concerning the establishment, condition or change in any aeronautical facility, service, procedure or hazard, the timely knowledge of which is essential to personnel concerned with flight operations.

Class I distribution. Distribution by means of telecommunication.

Class II distribution. Distribution by means other than telecommunication.

Obstacle clearance altitude/height (OCA/H). The lowest altitude (OCA), or alternatively the lowest height above the elevation of the relevant runway threshold or above the aerodrome elevation as applicable (OCH), used in establishing compliance with the appropriate obstacle clearance criteria.

Operational control. The exercise of authority over the initiation, continuation, diversion or termination of a flight in the interest of the safety of the aircraft, and the regularity and efficiency of flight.

Operator. A person, organization or enterprise engaged in or offering to engage in an aircraft operation.

Pilot-in-command. The pilot responsible for the operation and safety of the aircraft during flight time.

Positional response. That element of an SSR response which represents the actual position of the associated aircraft on the display.

Precision approach radar (PAR). Primary radar equipment used to determine the position of an aircraft during final approach, in terms of lateral and vertical deviations relative to a nominal approach path, and in range relative to touchdown.

Note.— Precision approach radars are designated to enable pilots of aircraft to be given guidance by radio-communication during the final stages of the approach to land.

Pressure-altitude. An atmospheric pressure expressed in terms of altitude which corresponds to that pressure in the Standard Atmosphere.*

Primary radar. A radar system which uses reflected radio signals.

Printed communications. Communications which automatically provide a permanent printed record at each terminal of a circuit of all messages which pass over such circuit.

Procedure turn. A manoeuvre in which a turn is made away from a designated track followed by a turn in the opposite direction to permit the aircraft to intercept and proceed along the reciprocal of the designated track.

Note 1.— Procedure turns are designated “left” or “right” according to the direction of the initial turn.

Note 2.— Procedure turns may be designated as being made either in level flight or while descending according to the circumstance of each individual instrument approach procedure, the only restriction being that the obstacle clearance specified in PANS-OPS (Doc 8168) not be infringed.

* As defined in Annex 8.

- Profile.** The orthogonal projection of a flight path or portion thereof on the vertical surface containing the nominal track.
- Prohibited area.** An airspace of defined dimensions, above the land areas or territorial waters of a State, within which the flight of aircraft is prohibited.
- Radar.** A radio detection device which provides information on range, azimuth and/or elevation of objects.
- Radar approach.** An approach, executed by an aircraft, under the direction of a radar controller.
- Radar blip.** A generic term for the visual indication, in non-symbolic form, on a radar display of the position of an aircraft obtained by primary or secondary radar.
- Radar clutter.** The visual indication on a radar display of unwanted signals.
- Radar contact.** The situation which exists when the radar blip or radar position symbol of a particular aircraft is seen and identified on a radar display.
- Radar control.** Term used to indicate that radar-derived information is employed directly in the provision of air traffic control service.
- Radar controller.** A qualified air traffic controller holding a radar rating appropriate to the functions to which he is assigned.
- Radar display.** An electronic display of radar-derived information depicting the position and movement of aircraft.
- Radar echo.** The visual indication on a radar display of a radar signal reflected from an object.
- Radar heading.** A magnetic heading given by a controller to a pilot on the basis of radar-derived information for the purpose of providing navigational guidance.
- Radar identification.** The process of correlating a particular radar blip or radar position symbol with a specific aircraft.
- Radar map.** Information superimposed on a radar display to provide ready indication of selected features.
- Radar monitoring.** The use of radar for the purpose of providing aircraft with information and advice relative to significant deviations from nominal flight path.
- Radar position symbol (RPS).** A generic term of the visual indication in a symbolic form, on a radar display, of the position of an aircraft obtained after digital computer processing of positional data derived from primary radar and/or SSR.
- Radar response (or SSR response).** The visual indication in non-symbolic form, on a radar display, of a radar signal transmitted from an object in reply to an interrogation.
- Radar separation.** The separation used when aircraft position information is derived from radar sources.
- Radar service.** Term used to indicate a service provided directly by means of radar.
- Radar tracking.** The act, by either a human or a computer, of following the movements of specific aircraft by means of radar for the purpose of ensuring a continuous indication of the identity, position, track and/or height of the aircraft.
- Radar track position.** An extrapolation of aircraft position by the computer based upon radar information and used by the computer for tracking purposes.
- Note.— In some cases, information other than radar-derived information is used to assist the tracking processes.*
- Radar unit.** That element of an air traffic services unit which uses radar equipment to provide one or more services.
- Radar vectoring.** Provision of navigational guidance to aircraft in the form of specific headings, based on the use of radar.
- Receiving unit/controller.** Air traffic services unit/air traffic controller to which a message is sent.
- Note.— See definition of sending unit/controller.*
- Release time.** Time prior to which an aircraft should be given further clearance or prior to which it should not proceed in case of radio failure.
- Reporting point.** A specified geographical location in relation to which the position of an aircraft can be reported.
- Rescue co-ordination centre.** A unit responsible for promoting efficient organization of search and rescue

service and for co-ordinating the conduct of search and rescue operations within a search and rescue region.

Rescue unit. A unit composed of trained personnel and provided with equipment suitable for the expeditious conduct of search and rescue.

Restricted area. An airspace of defined dimensions, above the land areas or territorial waters of a State, within which the flight of aircraft is restricted in accordance with certain specified conditions.

Route description. The unambiguous delineation of a route in terms of an ordered sequence of ATS route designators and/or significant points.

Route segment. A portion of a route to be flown, as defined by two consecutive significant points specified in a flight plan.

Route stage. A route or portion of a route flown without an intermediate landing.

Runway. A defined rectangular area on a land aerodrome prepared for the landing and take-off of aircraft.

Runway visual range. The range over which the pilot of an aircraft on the centre line of a runway can see the runway surface markings or the lights delineating the runway or identifying its centre line.

Secondary radar. A radar system wherein a radio signal transmitted from the radar station initiates the transmission of a radio signal from another station.

Secondary surveillance radar (SSR). A system of secondary radar using ground transmitters/receivers (interrogators) and airborne transponders conforming to specifications developed by ICAO.

Sending unit/controller. Air traffic services unit/air traffic controller transmitting a message.

Note.— See definition of receiving unit/controller.

Separation. Spacing between aircraft, levels or tracks.

Shoreline. A line following the general contour of the shore, except that in cases of inlets or bays less than 30 NM in width, the line shall pass directly across the inlet or bay to intersect the general contour on the opposite side.

SIGMET information. Information issued by a meteorological watch office concerning the occurrence or expected occurrence of specified en-route weather phenomena which may affect the safety of aircraft operations.

Signal area. An area on an aerodrome used for the display of ground signals.

Significant point. A specified geographical location used in defining an ATS route or the flight path of an aircraft and for other navigation and ATS purposes.

Simultaneous mode. A mode of ATS data interchange where information extracted from the filed flight plan is sent simultaneously in a filed flight plan message to all ATS units concerned along the route of flight.

Slush. Water-saturated snow which with a heel-and-toe slap-down motion against the ground will be displaced with a splatter; specific gravity: 0.5 up to 0.8.

Note.— Combinations of ice, snow and/or standing water may, especially when rain, sleet or snow is falling, produce substances with specific gravities in excess of 0.8. These substances, due to their high water/ice content, will have a transparent rather than a cloudy appearance and, at the higher specific gravities, will be readily distinguishable from slush.

Snow (on the ground).

- a) Dry snow. Snow which can be blown if loose or, if compacted by hand, will fall apart upon release; specific gravity: up to but not including 0.35.
- b) Wet snow. Snow which, if compacted by hand, will stick together and tend to or form a snowball; specific gravity: 0.35 up to but not including 0.5.
- c) Compacted snow. Snow which has been compressed into a solid mass that resists further compression and will hold together or break up into chunks if picked up; specific gravity: 0.5 and over.

Special VFR flight. A controlled VFR flight authorized by air traffic control to operate within a control zone under meteorological conditions below the visual meteorological conditions.

Standard altimeter setting. A pressure setting of 1013.2 hPa (1013.1 mb) which, when set on the subscale of the sensitive altimeter, will cause the altimeter to read zero when at mean sea level in the ICAO standard atmosphere.

Step-by-step mode. A mode of ATS data interchange where each ATS unit, as the flight progresses, transmits a current flight plan message to the next unit.

Sub-system. Any system which is associated with the air traffic control system as a provider and/or recipient of information relating to the provision of air traffic control service.

Surveillance radar. Radar equipment used to determine the position of an aircraft in range and azimuth.

Synthetic display. A display of computer-generated information, normally comprising aircraft positions and associated data presented in alphanumeric or symbolic form.

Tabular display. A display of information in the form of a table.

Target. In radar, 1) generally, any discrete object which reflects or retransmits energy back to the radar equipment; 2) specifically, an object of radar search or surveillance.

Taxiing. Movement of an aircraft on the surface of an aerodrome under its own power, excluding take-off and landing and, in the case of helicopters, operation over the surface of an aerodrome within a height band associated with ground effect and at speeds associated with taxiing, i.e. air-taxiing.

Taxiway. A defined path on a land aerodrome established for the taxiing of aircraft and intended to provide a link between one part of the aerodrome and another, including:

- a) Aircraft stand taxi lane. A portion of an apron designated as a taxiway and intended to provide access to aircraft stands only.
- b) Apron taxiway. A portion of a taxiway system located on an apron and intended to provide a through taxi route across an apron.
- c) Rapid exit taxiway. A taxiway connected to a runway at an acute angle and designed to allow landing aeroplanes to turn off at higher speeds than are achieved on other taxiways and thereby minimizing runway occupancy times.

Terminal area sequencing. The process of organizing traffic entering and departing from a terminal area into an orderly flow.

Terminal control area. A control area normally established at the confluence of ATS routes in the vicinity of one or more major aerodromes.

Threshold. The beginning of that portion of the runway usable for landing.

Touchdown. The point where the nominal glide path intercepts the runway.

Note.— Touchdown as defined above is only a datum and is not necessarily the actual point at which the aircraft will touch the runway.

Track. The projection on the earth's surface of the path of an aircraft, the direction of which path at any point is usually expressed in degrees from North (true, magnetic or grid).

Transfer of control. Transfer of responsibility for providing air traffic control service.

Note.— When the word "process" is used as a suffix to this term, it signifies the series of actions taken by two air traffic control units for the purpose of effecting transfer of responsibility from one unit to the other.

Transfer of control point. A defined point located along the flight path of an aircraft, at which the responsibility for providing air traffic control service to the aircraft is transferred from one control unit or control position to the next.

Transferring unit/controller. Air traffic control unit/air traffic controller in the process of transferring the responsibility for providing air traffic control service to an aircraft to next air traffic control unit/air traffic controller along the route of flight.

Note.— See definition of Accepting unit/controller.

Transition altitude. The altitude at or below which the vertical position of an aircraft is controlled by reference to altitudes.

Transition layer. The airspace between the transition altitude and the transition level.

Transition level. The lowest flight level available for use above the transition altitude.

Transponder. A receiver/transmitter which will generate a reply signal upon proper interrogation; the interrogation and reply being on different frequencies.

True airspeed. The speed of the aeroplane relative to undisturbed air.

Uncertainty phase. A situation wherein uncertainty exists as to the safety of an aircraft and its occupants.

Unlimited route concept. A concept of controlled airspace organization which allows an operator complete freedom to choose the route to be taken by a flight from one point to another provided that the route is adequately defined in the flight plan and adhered to as accurately as circumstances permit.

Unmanned free balloon. A non-power driven, unmanned lighter-than-air aircraft in free flight.

Note.— Unmanned free balloons are classified as heavy, medium or light in accordance with specifications contained in Annex 2, Appendix D.

Vertical separation. Separation between aircraft expressed in units of vertical distance.

VFR. The symbol used to designate the visual flight rules.

VFR flight. A flight conducted in accordance with the visual flight rules.

Visibility. The ability, as determined by atmospheric conditions and expressed in units of distance, to see and identify prominent unlighted objects by day and prominent lighted objects by night.

Visual approach. An approach by an IFR flight when either part or all of an instrument approach procedure is not completed and the approach is executed in visual reference to terrain.

Visual meteorological conditions. Meteorological conditions expressed in terms of visibility, distance from cloud, and ceiling, equal to or better than specified minima.

Note.— The specified minima are contained in Annex 2, Chapter 4.

VMC. The symbol used to designate visual meteorological conditions.

Way-point. A specified geographical location used to define an area navigation route or the flight path of an aircraft employing area navigation.



Chapter 2

Commonly Used Abbreviations

2.1 INTRODUCTION

Abbreviations which are defined in the *Procedures for Air Navigation Services — ICAO Abbreviations and Codes* (Doc 8400) are used in accordance with the meanings and usages given therein. However, there still remains a wide variety of abbreviations and codes in use throughout the world in international aeronautical telecommunications service, aeronautical information documents and air traffic services. As far as possible, the abbreviations used in this document and outlined below are those which have the widest international use.

2.2 ABBREVIATIONS

2.2.1 When the following abbreviations are used in this manual, they have the following meanings:

ACC	area control centre or area control
ADF	automatic direction-finder
ADIZ	Air Defence Identification Zone
ADREP	accident/incident reporting system
ADSEL	address selective
AFI	African-Indian Ocean Region
AFIS	aerodrome flight information service
AFTN	aeronautical fixed telecommunication network
AGA	Aerodromes, Air Routes and Ground Aids
AGL	above ground level
AIP	aeronautical information publication
AIRAC	aeronautical information regulation and control
AIS	aeronautical information service
AMR	airport movement radar
APP	approach control
ASDE	airport surface detection equipment
ASR	aerodrome surveillance radar
ATC	air traffic control
ATFM	air traffic flow management
ATIS	automatic terminal information service

ATS	air traffic services
ATSPM	Air Traffic Services Planning Manual
BRITE	bright radar indicator tower equipment
CAA	Civil Aviation Authority (UK)
CAT	Category
CCTV	closed circuit television
CIDIN	common ICAO data interchange network
COM	communications
CPL	current flight plan
CRT	cathode-ray tube
CTA	control area
CW	continuous wave
DABS	discrete address beacon system
DAVSS	Doppler acoustic vortex sensing equipment
DH	decision height
DVOR	Doppler VHF omni-directional radio range (VOR)
DME	distance measuring equipment
DF	direction finder
EDP	electronic data processing
EST	estimate
ETA	estimated time of arrival
ETG	electronic target generator (APP — radar simulator)
EUR	European Region
FAA	Federal Aviation Administration (United States)
FACSFAC	Fleet Area Control Surveillance Facility (United States)
FIC	flight information centre
FIR	flight information region
FIS	flight information service
FL	flight level
FPL	filed flight plan
FSS	Flight Service Station
GMT	Greenwich Mean Time
GWVSS	ground wind vortex sensing system
HELIOPS	helicopter operations
HF	high frequency
IATA	International Air Transport Association
IFATCA	International Federation of Air Traffic Controllers' Associations
IFALPA	International Federation of Air Line Pilots' Associations

IFIP	International Federation for Information Processing	RNAV	area navigation
IFR	instrument flight rules	RTF	radiotelephony
ILO	International Labour Organisation	RVR	runway visual range
ILS	instrument landing system	SAM	South America Region
IMC	instrument meteorological conditions	SAR	search and rescue
INS	inertial navigation systems	SARPs	Standards and Recommended Practices
ISO	International Organization for Standardization	SID	standard instrument departure
ITU	International Telecommunication Union	SIGMET	significant meteorological
LARS	lower airspace radar service	SMGC	surface movement guidance control
LF	low frequency	SMR	surface movement radar
LOP	line of position	SPI	special position identification pulse
LORAN	long range air navigation system	SSR	secondary surveillance radar
MET	meteorology	SST	supersonic transport
MF	medium frequency	STAR	standard (instrument) arrival route
MLS	microwave landing system	TACAN	tactical air navigation aid
MNPS	minimum navigation performance specifications	TAS	true airspeed
MOAs	military operations areas	TMA	terminal control area
NAT	North Atlantic Region	TMC	terminal control
NAT/SPG	North Atlantic Systems Planning Group	TRSB	time reference scanning beam
NDB	non-directional radio beacon	TVOR	terminal VHF omni-directional radio range (VOR)
NTZ	no transgression zone	TWR	aerodrome control tower or aerodrome control
OAC	oceanic area control centre	UHF	ultra high frequency
OFIS	operational flight information service	UIR	upper flight information region
OPS	operations	UPS	uninterruptible power supply
PAC	Pacific Region	UTC	Co-ordinate Universal Time
PANS-RAC	Procedures for Air Navigation Services — Rules of the Air and Air Traffic Services	VAS	vortex advisory system
PAR	precision approach radar	VDF	very high frequency (VHF) direction-finder (DF)
PCS	power conditioning system	VFR	visual flight rules
PPI	plan position indicator	VHF	very high frequency
PSR	primary surveillance radar	VLF	very low frequency
PVOR	precision VHF omni-directional radio range (VOR)	VMC	visual meteorological conditions
RGCSF	Review of the General Concept of Separation Panel	VOR	very high frequency (VHF) omni-directional radio range
RPL	repetitive flight plan	VORTAC	collocated VHF omni-directional radio range (VOR) and tactical air navigation (TACAN)
rpm	revolutions per minute	VWS	vortex wake system
RPS	radar position symbol	WVAS	automated wake vortex avoidance system

AIR TRAFFIC SERVICES PLANNING MANUAL

PART V

SECTION 2. REFERENCES

SECTION 2 REFERENCES

Contents

	<i>Page</i>
Chapter 1. References and Source Documents	V-2-1-1
1.1 Conventions and related acts	V-2-1-1
1.2 Annexes to the Convention on International Civil Aviation	V-2-1-1
1.3 Procedures for air navigation services ..	V-2-1-1
1.4 Regional supplementary procedures	V-2-1-1
1.5 Technical publications	V-2-1-1

Chapter 1

References and Source Documents

1.1 CONVENTIONS AND RELATED ACTS

- a) *Convention on International Civil Aviation* (Doc 7200)
- b) *Convention for the Suppression of Unlawful Seizure of Aircraft* (Doc 8920)
- c) *Convention for the Suppression of Unlawful Acts Against the Safety of Civil Aviation* (Doc 8966)

1.2 ANNEXES TO THE CONVENTION ON INTERNATIONAL CIVIL AVIATION

- a) Annex 1 — *Personnel Licensing*
- b) Annex 2 — *Rules of the Air*
- c) Annex 3 — *Meteorological Service for International Air Navigation*
- d) Annex 4 — *Aeronautical Charts*
- e) Annex 5 — *Units of Measurement to be Used in Air and Ground Operations*
- f) Annex 6 — *Operation of Aircraft*
 - Part I — International Commercial Air Transport*
 - Part II — International General Aviation*
- g) Annex 8 — *Airworthiness of Aircraft*
- h) Annex 10 — *Aeronautical Telecommunications*
 - Volume I (Part I — Equipment and Systems; Part II — Radio Frequencies)*
- i) Annex 10 — *Aeronautical Telecommunications*
 - Volume II (Communications Procedures including those with PANS status)*
- j) Annex 11 — *Air Traffic Services*
- k) Annex 12 — *Search and Rescue*
- l) Annex 13 — *Aircraft Accident Investigation*
- m) Annex 14 — *Aerodromes*
- n) Annex 15 — *Aeronautical Information Services*
- o) Annex 17 — *Security — Safeguarding International Civil Aviation Against Acts of Unlawful Interference*

1.3 PROCEDURES FOR AIR NAVIGATION SERVICES

- a) *ICAO Abbreviations and Codes* (Doc 8400)
- b) *Aircraft Operations* (Doc 8168)
 - Volume I — Flight Procedures*
 - Volume II — Construction of Visual and Instrument Flight Procedures*
- c) *Rules of the Air and Air Traffic Services* (Doc 4444)

1.4 REGIONAL SUPPLEMENTARY PROCEDURES

Regional Supplementary Procedures (Doc 7030)

1.5 TECHNICAL PUBLICATIONS

- a) AGA — *Aerodromes, Air Routes and Ground Aids*
 - 1) *Aerodrome Design Manual* (Doc 9157)
 - 2) *Airport Planning Manual* (Doc 9184)
 - Part 1. *Master Planning*
 - 3) *Airport Services Manual* (Doc 9137)
 - Part 1. *Rescue and Fire Fighting*
 - Part 3. *Bird Control and Reduction*
 - Part 4. *Fog Dispersal*
 - Part 5. *Removal of Disabled Aircraft*
 - Part 6. *Control of Obstacles*
 - Part 7. *Airport Emergency Planning*
 - 4) *Heliport Manual* (Doc 9261)
 - 5) *Surface Movement Guidance and Control Systems*, (Circular 148)
- b) AIG — *Accident Investigation and Prevention*
 - 1) *Accident/Incident Reporting Manual (ADREP Manual)* (Doc 9156)
 - 2) *Manual of Aircraft Accident Investigation* (Doc 6920)

- c) AIS — Aeronautical Information and Charts
 - 1) *Aeronautical Chart Manual* (Doc 8697)
 - 2) *Aeronautical Information Services Manual* (Doc 8126)
 - 3) *Measures to Improve the Aeronautical Information Services* (Circular 156)
- d) COM — Communications
 - 1) *Designators for Aircraft Operating Agencies, Aeronautical Authorities and Services* (Doc 8585)
 - 2) *Location Indicators* (Doc 7910)
 - 3) *Manual on Testing of Radio Navigation Aids* (Doc 8071)
 - Volume I
 - Volume II — *Instrument Landing System (ILS)*
 - 4) *Aviation Use of Omega* (Circular 139)
 - 5) *Microwave Landing System (MLS) Advisory Circular Issue No. 1* (Circular 165)
 - 6) *Secondary Surveillance Radar Mode S Advisory Circular* (Circular 174)
 - 7) *ATS Speech Circuits — Guidance Material on Switched Network Planning* (Circular 183)
- e) MET — Meteorology
 - 1) *Manual of Runway Visual Range Observing and Reporting Practices* (Doc 9328)
 - 2) *Manual on Co-ordination Between Air Traffic Services and Aeronautical Meteorological Services* (Doc 9377-AN/915)
- f) OPS/AIR — Operations and Airworthiness
 - 1) *Airworthiness Technical Manual* (Doc 9051)
 - 2) *Manual on the Use of the Collision Risk Model (CRM) for ILS Operations* (Doc 9274)
 - 3) *Manual of All-Weather Operations* (Doc 9365)
 - 4) *Instrument Flight Procedures Construction Manual* (Doc 9368)
 - 5) *Manual of Model Regulations for National Control of Flight Operations and Continuing Airworthiness of Aircraft* (Doc 9388)
 - 6) *Guidance Material on SST Aircraft Operations* (Circular 126)
- g) PEL/TRG — Personnel Licensing and Training Practices
 - 1) *Manual of Licensing Practices and Procedures* (Doc 9057)
 - 2) *Training Manual* (Doc 7192)
 - Part A-1 — *General Considerations*
 - Part D-2 — *Air Traffic Controller*
 - 3) *Manual of Procedures for Establishment And Management of a State's Licensing System* (Doc 9379)
- h) RAC/SAR — Rules of the Air, Air Traffic Services and Search and Rescue
 - 1) *Aircraft Type Designators* (Doc 8643)
 - 2) *Search and Rescue Manual* (Doc 7333)
 - Part 1 — *The Search and Rescue Organization*
 - Part 2 — *Search and Rescue Procedures*
 - 3) *Methodology for the Derivation of Separation Minima Applied to the Spacing Between Parallel Tracks in ATS Route Structures* (Circular 120)

— END —

ICAO TECHNICAL PUBLICATIONS

The following summary gives the status, and also describes in general terms the contents of the various series of technical publications issued by the International Civil Aviation Organization. It does not include specialized publications that do not fall specifically within one of the series, such as the Aeronautical Chart Catalogue or the Meteorological Tables for International Air Navigation.

International Standards and Recommended Practices are adopted by the Council in accordance with Articles 54, 37 and 90 of the Convention on International Civil Aviation and are designated, for convenience, as Annexes to the Convention. The uniform application by Contracting States of the specifications contained in the International Standards is recognized as necessary for the safety or regularity of international air navigation while the uniform application of the specifications in the Recommended Practices is regarded as desirable in the interest of safety, regularity or efficiency of international air navigation. Knowledge of any differences between the national regulations or practices of a State and those established by an International Standard is essential to the safety or regularity of international air navigation. In the event of non-compliance with an International Standard, a State has, in fact, an obligation, under Article 38 of the Convention, to notify the Council of any differences. Knowledge of differences from Recommended Practices may also be important for the safety of air navigation and, although the Convention does not impose any obligation with regard thereto, the Council has invited Contracting States to notify such differences in addition to those relating to International Standards.

Procedures for Air Navigation Services (PANS) are approved by the Council for world-wide application. They contain, for the most part, operating procedures regarded as not yet having attained a sufficient degree of

maturity for adoption as International Standards and Recommended Practices, as well as material of a more permanent character which is considered too detailed for incorporation in an Annex, or is susceptible to frequent amendment, for which the processes of the Convention would be too cumbersome.

Regional Supplementary Procedures (SUPPS) have a status similar to that of PANS in that they are approved by the Council, but only for application in the respective regions. They are prepared in consolidated form, since certain of the procedures apply to overlapping regions or are common to two or more regions.

The following publications are prepared by authority of the Secretary General in accordance with the principles and policies approved by the Council.

Technical Manuals provide guidance and information in amplification of the International Standards, Recommended Practices and PANS, the implementation of which they are designed to facilitate.

Air Navigation Plans detail requirements for facilities and services for international air navigation in the respective ICAO Air Navigation Regions. They are prepared on the authority of the Secretary General on the basis of recommendations of regional air navigation meetings and of the Council action thereon. The plans are amended periodically to reflect changes in requirements and in the status of implementation of the recommended facilities and services.

ICAO Circulars make available specialized information of interest to Contracting States. This includes studies on technical subjects.

© ICAO 1984
1/85, E/P1/3000; 3/92, E/P2/300;
9/93, E/P3/600; 10/97, E/P4/500

Order No. 9426
Printed in ICAO